

Hardware Specifications

MONITOUCH V6



Record of Revision

Printing Date	Reference No.	Revised Contents
February, 1998	2006NE0	(First Edition)
February, 1999	2006NE0a	(Second Edition)
January, 1999	2006NE0b	[A partial revision] Matrix type Multi-Link 2 Temperature Control Network Change model names of V6 CBM printer supported MITSUBISHI FX2N series, QnH OMRON SYSMAC CS1 A,B Micro Logix1000 SIEMENS S7-200 KEYENCE KZ-A500 CPU Port, KV series FATEK AUTOMATION FB series IDEC MICRO3 MODICON Modbus RTU YAMATAKE MX 200/50
March, 2000	2006NE1	[A partial revision] SIEMENS S5 PG port TAIANTP02
November, 2000	2006NE2	[A partial revision] V606i MITSUBISHI QnH CPU port YOKOGAWA FA-M3R OMRON CS1 DNA LG MKX00S CPU port FATEK AUTOMATION FB series
July, 2001	2006NE3	[A partial revision] Koyo SU/SG(K-Sequence) KEYENCE KV700 series CPU LG MASTER-KxxxS CNET, GLOFA CNET SAIA PCD MOELLER PS4 Automationdirect Direct LOGIC, Direct LOGIC(K-Sequence) CE Marking and UL Mark
August, 2002	2006NE4	[A partial revision]

Printing Date	Reference No.	Revised Contents
April, 2003	2006NE5	[A partial revision] VIGOR DELTA BALDOR Appendix : Ladder Transfer Function

Preface

Thank you for selecting the MONITOUCH V6 series.

For proper set-up, you are requested to read through this booklet to understand more about the product.

For more information about V6 series, refer to the Reference Manual.

For further details about the PLC, see the manual attached to each PLC.

Notes:

1. This booklet may not, in whole or in part, be printed or reproduced without the prior written consent of Hakko Electronics Co., Ltd.
2. Information in this booklet is subject to change without prior notice.
3. This booklet is intended to give information about MONITOUCH hardware.

Notes on safe usage of MONITOUCH

In this "Hardware Specifications", you will find various notes categorized under the following three levels with the signal words "Danger," "Warning," and "Caution."

These signal words are to warn the user of possible misuse of the unit. To comprehend the critical notes on the safe procedure, you must go through this manual before you install MONITOUCH and operate it correctly.



DANGER

Danger

indicates an imminently hazardous situation which, if not avoided, will result in death or serious injury.



WARNING

Warning

indicates a potentially hazardous situation which, if not avoided, could result in death or serious injury.



CAUTION

Caution

indicates a potentially hazardous situation which, if not avoided, may result in minor or moderate injury and could cause property damage.

Notes on System Design



WARNING

Never use the input function of MONITOUCH such as the touch switch for an emergency switch because it could threaten a human life or break a part of the unit.

Please design the system of the unit in order to respond to a malfunction of the touch switch.



CAUTION

Prevent the static electricity from being charged on the sheet metal where MONITOUCH is mounted to avoid malfunction caused by noise.

Never bundle input/output cables with high-voltage and large-current cables such as power supply cables. Keep input/output cables at least 200mm away from power supply cables in order to avoid malfunction caused by noise.

As for the use in the facilities related to nuclear energy or in the facilities of official importance, please consult with our distributor about it.

Notes on Installation



CAUTION

Operate MONITOUCH under the conditions indicated by the manual.

If you don't set the conditions indicated by the manual for the unit, it could cause fire, malfunction, physical damage or deterioration.

Maintain the following conditions in order to avoid fire or trouble.

Don't let the unit come in contact with corrosive gas, flammable gas, solvents, grinding fluids or cutting oil.



Never let the unit be exposed to high temperature, high humidity, and other outside weather conditions.

Don't allow the unit to be exposed to excessive dust, salt, and metallic particles.



Don't allow the unit to be shaken or hit by other objects.

Equipment must be correctly mounted so that the main terminal will not inadvertently be touched during an application.

Notes on Cable Connection

 DANGER	<p>Turn off the power supply when you set up the system or connect the cables, otherwise you will get an electric shock or damage the unit.</p>
 CAUTION	<p>Connect the cables correctly to the terminals of MONITOUCH in accordance with the specified voltage and wattage. Over-voltage, over-wattage and the incorrect cable connection could cause the unit to be damaged physically or functionally and also could result in fire.</p>
	<p>Ground FG terminal which must be for the unit. The level of grounding resistance is less than 100Ω.</p>
	<p>Prevent any conductive particles from entering into MONITOUCH. The conductive particles could cause fire, trouble, or malfunction of the unit.</p>

Notes on Maintenance and Operation

 DANGER	<p>Never touch the terminals while the power supply is on, otherwise you will get an electric shock.</p>
	<p>You must put the cover of the terminals on the unit when you turn on the power and operate it.</p>
	<p>The liquid crystal in the LCD panel is a hazardous substance. If the LCD panel is damaged, never swallow the leaked liquid crystal. If the liquid crystal spills on your skin or clothing, use soap and wash off thoroughly.</p>
 CAUTION	<p>Hakko Electronics Co., Ltd. is not responsible for an unauthorized person who may fix, disassemble, or reconstruct any unit.</p>
	<p>Switch resolution of the MONITOUCH V6 series is determined by the analog-type resistance film. Do not press two or more positions on the screen at the same time.</p> <p>If two or more positions are pressed at the same time, the switch located between the pressed positions activates. Please take note of this.</p>
	<p>Avoid displaying the same patterns for hours.</p> <p>It may cause afterimages due to the property of LCD display. If you use the fixed patterns for hours, use the auto-OFF function of the backlight.</p>

Notes on Disposal



CAUTION

At the time of disposal, MONITOUCH must be treated as industrial waste.

Contents

1. Hardware Specifications

1. Special Features	1-1
2. Notes on Usage	1-2
3. System Composition	1-4
4. Names of Components	1-10
5. Dimensions and Panel Cut-out	1-12
6. Mounting Procedure	1-17
7. Wiring	1-18
8. Specifications	1-20
9. Serial Connector (CN1)	1-26
10. Setting of Dip Switches	1-28
11. Modular Jack 1 & 2	1-29
12. Bar Code Reader Interface	1-30
13. Printer Interface (CN2)	1-31
14. Video Interface	1-32
15. Connection	1-33
16. Operation of V6 Main Menu	1-38
17. Function Switches	1-49

2. Connection to Link Units

1. MITSUBISHI PLC • 1	2-1
2. MITSUBISHI PLC • 2	2-7
3. MITSUBISHI PLC • 3	2-11
4. MITSUBISHI PLC • 4	2-13
5. MITSUBISHI PLC • 5	2-17
6. MITSUBISHI PLC • 6	2-20
7. OMRON PLC • 1	2-22
8. OMRON PLC • 2	2-27
9. Sharp PLC • 1	2-28
10. Sharp PLC • 2	2-31
11. HITACHI PLC • 1	2-33
12. HITACHI PLC • 2	2-36
13. Matsushita PLC	2-39
14. YOKOGAWA PLC • 1	2-42
15. YOKOGAWA PLC • 2	2-44
16. YASKAWA PLC • 1	2-47
17. YASKAWA PLC • 2	2-50
18. TOYOPUC PLC	2-52
19. FUJI PLC • 1	2-55
20. FUJI PLC • 2	2-58
21. FUJI PLC • 3	2-61
22. FUJI PLC • 4	2-63

23. Koyo PLC	2-65
24. Allen-Bradley PLC • 1	2-70
25. Allen-Bradley PLC • 2	2-75
26. GE Fanuc PLC • 1	2-79
27. GE Fanuc PLC • 2	2-81
28. TOSHIBA PLC	2-83
29. TOSHIBA MACHINE PLC	2-85
30. SIEMENS PLC • 1	2-87
31. SIEMENS PLC • 2	2-89
32. SIEMENS PLC • 3	2-91
33. SIEMENS PLC • 4	2-93
34. SIEMENS PLC • 5	2-95
35. SIEMENS PLC • 6	2-97
36. Shinko PLC	2-99
37. SAMSUNG PLC	2-101
38. KEYENCE PLC • 1	2-103
39. KEYENCE PLC • 2	2-105
40. KEYENCE PLC • 3	2-108
41. LG PLC	2-110
42. FANUC PLC	2-115
43. FATEK AUTOMATION PLC	2-117
44. IDEC PLC	2-119
45. MODICON PLC	2-121
46. YAMATAKE PLC	2-123
47. TAIAN PLC	2-125
48. SAIA PLC	2-127
49. MOELLER PLC	2-129
50. Telemecanique PLC	2-130
51. Automationdirect PLC	2-132
52. VIGOR PLC	2-135
53. DELTA PLC	2-137
54. BALDOR PLC	2-139

Appendix

Ladder Transfer Function	Appendix-1
--------------------------------	------------

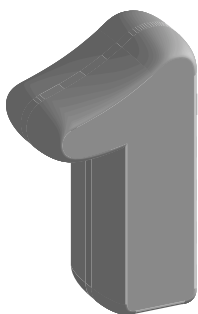

Hardware Specifications

1. Special Features
2. Notes on Usage
3. System Composition
4. Names of Components
5. Dimensions and Panel Cut-out
6. Mounting Procedure
7. Wiring
8. Specifications
9. Serial Connector (CN1)
10. Setting of Dip Switches
11. Modular Jack 1 & 2
12. Bar Code Reader Interface
13. Printer Interface (CN2)
14. Video Interface
15. Connection
16. Operation of V6 Main Menu
17. Function Switches

1 Special Features

- 1) 128-color Display
128-color display makes colorful expression possible. Not only drawings but also bitmap files are clearly displayed.
- 2) Data Sheet Printing Function
It is possible to make the original data sheet screen by the panel editor (= the editing software). Daily reports or monthly reports that the operator must fill out can be printed in an instant.
- 3) Sampling Function
This function makes it possible to store the sampling data in an IC card. The stored data can be edited easily by a personal computer. It can be used widely in various fields.
- 4) Macro Function
With this function, V6 series can make programs which previously had to be produced by PLC.
- 5) Multi Window Function
Up to three windows can be displayed simultaneously on a screen.
It is easy to move or delete the displayed windows.
- 6) Video Function
V6 series can be connected to a video or a CCD camera, and the image which is taken by a video or a camera can be displayed directly in a screen of V6 series.
- 7) V606, V606i
A 5.7 inch display with 320 X 240 dot resolution.
- 8) V608C
A 7.7 inch display with VGA (640 X 480 dot resolution).
- 9) V610
A 10.4 inch standard model display which uses the previous screen data.
- 10) V612
A 12.1 inch large display with SVGA (800 X 600 dot resolution).

2 Notes on Usage



Environmental Limits

1. Use MONITOUCH at an ambient temperature of 0~50°C, and a relative humidity of 85 %RH. (But, a V610 STN multi-color display can be used at 0-40°C.)

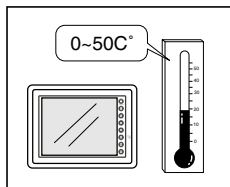

2. Install a forced fan or an air conditioner to maintain the ambient temperature when it is higher than the above mentioned range.

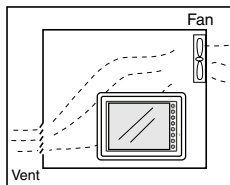

3. Avoid places where moisture may easily condense due to sudden temperature changes.

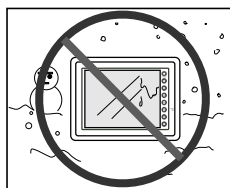

4. Avoid direct sunlight.

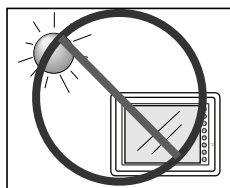

5. Never install MONITOUCH in a place where impacts or vibrations may be transmitted.

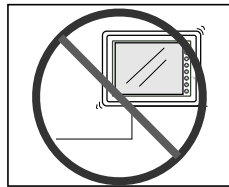

6. Avoid any place in which there is the possibility that water, corrosive gas, flammable gas, solvents, grinding fluids or cutting oil can come in contact with the unit. Never install the unit in a place where dust, salt and metallic particles are present.

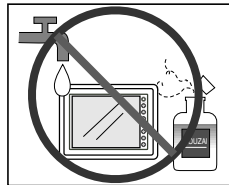

Locations

1. Secure sufficient space around MONITOUCH for ventilation.

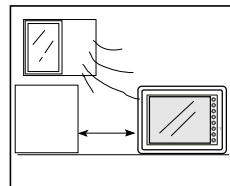

2. Never attach MONITOUCH to the top of any apparatus generating high levels of heat (heater, transformer, large-capacity resistor, etc.).



- Never install MONITOUCH in the same compartment as high-voltage equipment. The unit should be at least 200 mm away from high-voltage lines or power cables.

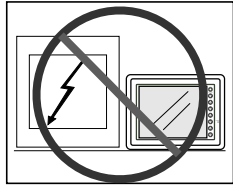

- Securely fasten and lock every connector for each cable. Double-check this before turning the power on.

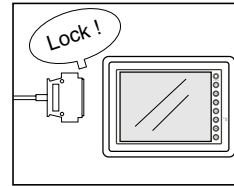

- In a dry environment, MONITOUCH may generate a large amount of static electricity. Therefore, before touching the unit, touch a grounded metallic section to discharge the static electricity.

Usage

- An emergency stop circuit must be composed of an external relay circuit with a start signal for MONITOUCH built in. Do not create switches on MONITOUCH to be used in case of emergency.

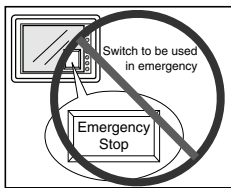

- A receiving error may occur on a device that is connected to MONITOUCH such as a PLC or a temperature controller by starting up both equipments at the same time. In such case, follow the instructions of such device's manuals to handle the error.

- Application of thinner may discolor MONITOUCH. Use alcohol or benzine available commercially for cleaning.

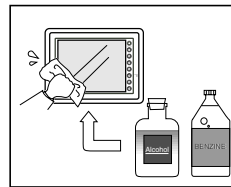

- MONITOUCH has a glass screen. Never drop or subject the unit to strong impacts.

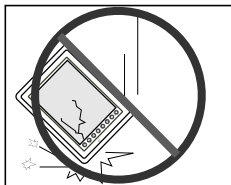

- Never remove any printed circuit board from MONITOUCH. (This will harm the unit.)

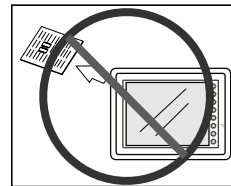

- Tighten mounting screws with the following torques.

Type	Screw	Screw Size	Torque (N·m(kgf·cm))
	V606/608	M3	0.3-0.5 (3-5)
	V606i	M4	0.3-0.5 (3-5)
	V610/612	M4	0.5-0.7 (5-7)

Note :Never fasten these screws too tightly, otherwise the cover of MONITOUCH may be deformed.

- Never operate the display by using a tool with a sharp point like a screwdriver. Touch the display by fingers.

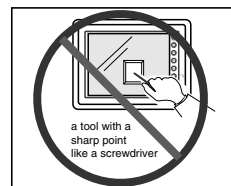

3 System Composition

System Composition / Model Indication / Peripheral Equipment

System Composition

The following illustration shows possible system configurations using V6.

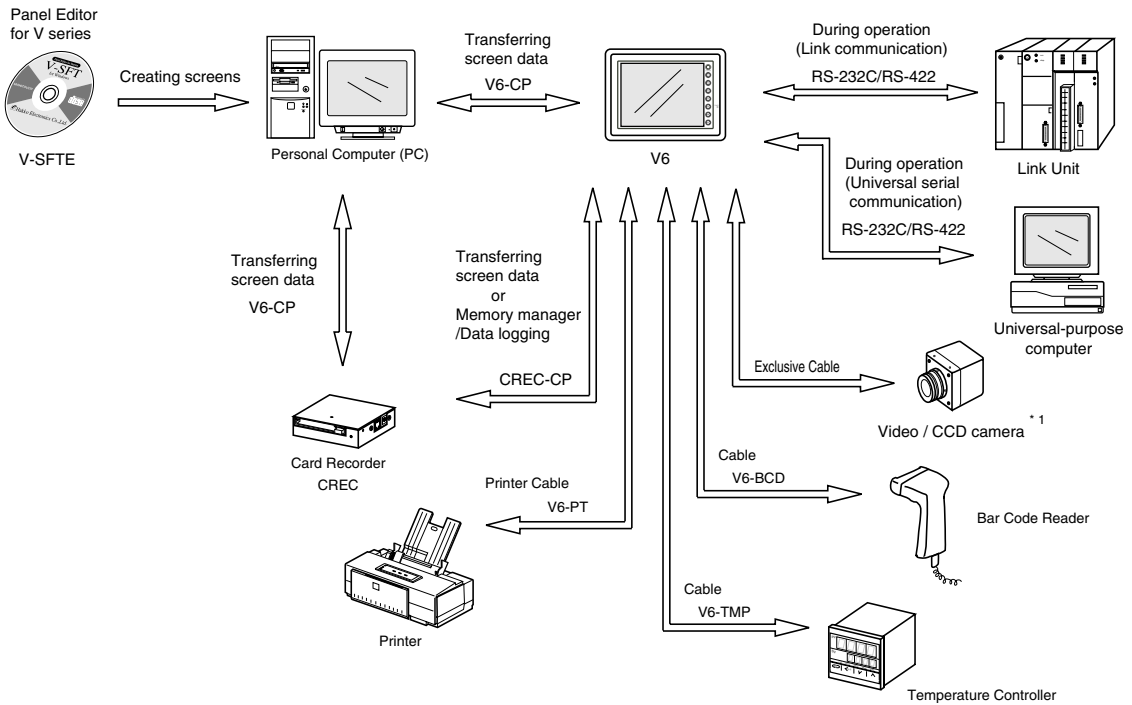

*1 The interface for video function (using only in V610T/S and V612T) is optional for Maker.

List of Models

The characters on the right of model names represent optional features and special specifications.

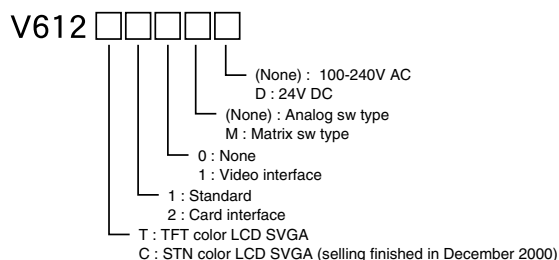
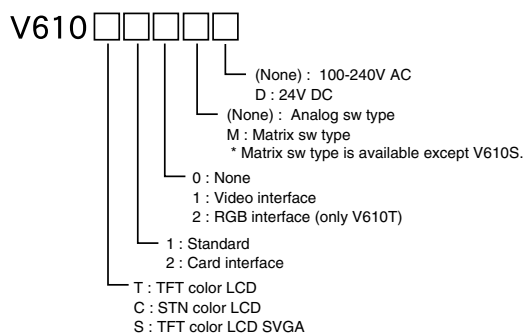
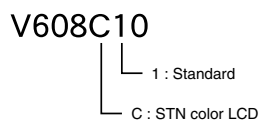
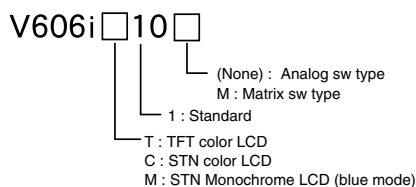
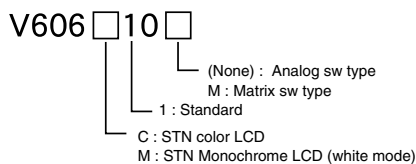

All type of model have the printer port.

Models compatible with Overseas Specifications (CE Marking and UL Mark)

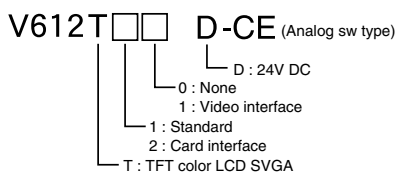
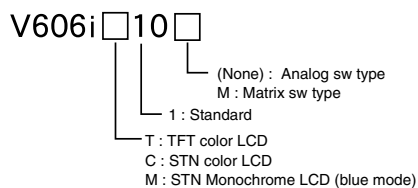
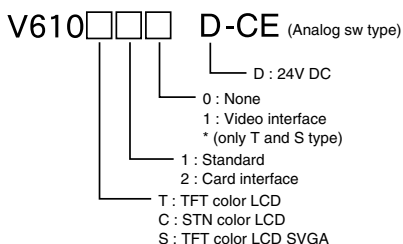
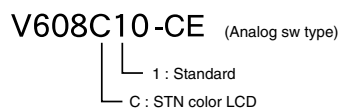
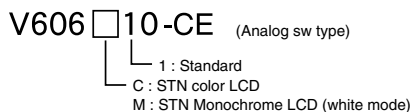

All type of model have the printer port.

List of Options

Item		Type	V606 C/M	V606i T/C/M	V608C	V610C	V610T	V610S	V612C	V612T
Optional by Manufacturer	Card Interface *1		×	×	×	○		○	○	
	Video Interface		×	×	×	×	○	○	×	○
	Analog RGB Input Interface		×	×	×	×	○	×	×	
Optional by User	Extension I/O Unit : E-I/O (16 inputs / 16 outputs)		×	×	×	○		○	○	
	Serial Extension I/O : V-I/O (16 inputs / 16 outputs)		○	○	○	○		○	○	
	FPROM Cassette (4Mbyte)	V6EM/4	×	×	○	○		○	○	
		V6EM/4i	×	○	×	×		×	×	
	SRAM Cassette (512kbyte)	V6EM/RS	×	×	○	○		○	○	
		V6EM/RSi	×	○	×	×		×	×	
	Communication Interface Unit : CU-00, 01, 02, 03, 04, 05 *2		×	○	○	○		○	○	
	Communication Interface Unit for V606 : CUS-00, 01 *2		○	×	×	×		×	×	
Card Recorder *1 : CREC		○	○	○	○		○	○		
Terminal Converter : TC485		○	○	○	○		○	○		

*1 Prepare for V6 with card interface, or V6 and CREC(card recorder).

*2 CU-00/CUS-00 : JPCN-1, CU-01/CUS-01: T-LINK, CU-02 : CC-LINK,
CU-03 : Ethernet or FL-net, CU-04 : PROFIBUS, CU-05 : MELSEC-NET10

Model Indication

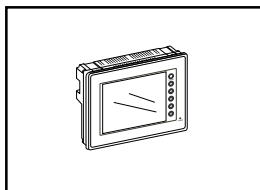

V606

A 5.7 inch display.

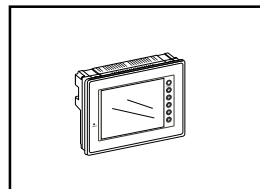

V606i

A 5.7 inch display.

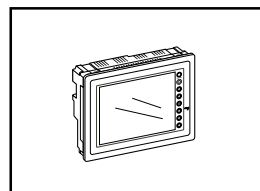

V608

A 7.7 inch display.

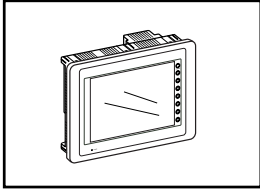
**V610**

A 10.4 inch display.

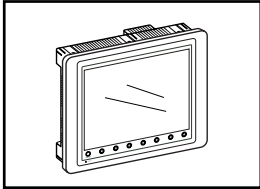
**V612**

A 12.1 inch display.

Peripheral Equipment

The following options are available for using V6 series more effectively.

**V-SFT****(Panel Editor for Windows98/NT4.0/Me/2000/XP)**

Application software for editing display data for V series.

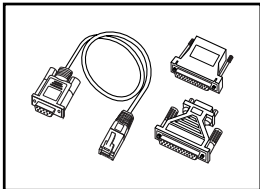
**V6-CP (Data Transfer Cable) 3m**

Connects V6 to a personal computer, or a personal computer to CREC.

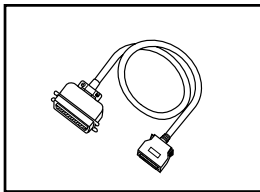
**V6-PT (Printer Cable) 2.5m**

Connects V6 to a printer.

When using CBM292/293 printer, our printer cable "V6-PTCBM" is available.

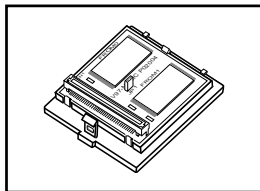
**V6EM/4 · V6EM/4i (FPRM Cassette)**

- V6EM/4 : for V608, V610, V612
- V6EM/4i : for V606i

Extension print circuit board to extend the memory for display data back-up. There is 4Mbyte type.

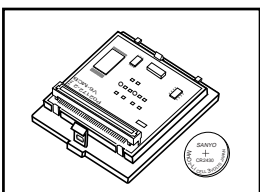
**V6EM/RS · V6EM/RSi (SRAM Cassette)**

- V6EM/RS : for V608, V610, V612
- V6EM/RSi : for V606i

Extension print circuit board to back-up the memory for sampling data, Internal Memory and Memo Pad. There is 512kbyte type. It is also possible to set the calendar for displaying in V6 at this cassette.

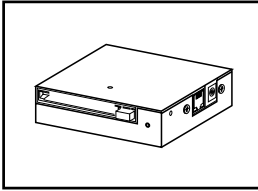

CREC (Card Recorder)

Reads display data created by personal computer, or works as an external memory storage system for the memory manager and data logging functions.

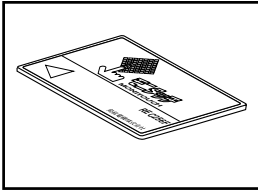

REC-MCARD (Memory Card)

complies with JEIDA Ver.4.0

Used as a recording medium for display data back-up and for the memory manager or data logging function.

SRAM 256K, 512K, 1M, 2M, 4Mbyte

FLASH ROM 256K, 512K, 1M, 16Mbyte



M-CARD SFT (Memory Card Editor)

Application software for editing data stored in a memory card.

(For Windows98/NT 4.0/Me/2000/XP)

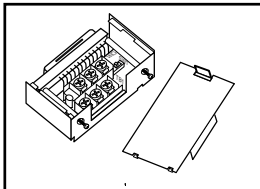

TC485 (Terminal Converter)

Used for connection between a V6 and a PLC at the RS-422/485 terminal block.

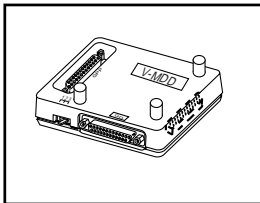

V-MDD (ACPU/QnACPU/FXCPU Dual Port Interface)

Add-on connector with two ports, specifically designed for the connector on the MITSUBISHI's ACPU/QnACPU/FXCPU programmer. This can improve operability of the ACPU/QnACPU/FXCPU programmer that is directly connected.

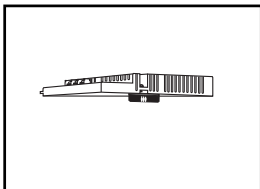

CU-xx [xx : 00 -> JPCN1, 01 -> T-LINK, 02 -> CC-LINK, 03 -> Ethernet or FL-net, 04 -> PROFIBUS, 05 -> MELSEC-NET10] (Communication Interface Unit)

Used to communicate with each network.

It makes it possible to connect multiple V6 series to a PLC. This system, which enables other devices to connect to the same network, brings about the reduction in costs of the whole system.

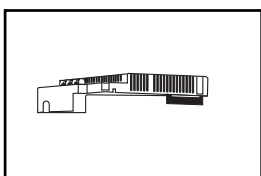

CUS-XX [00 -> JPCN1, 01 -> T-LINK]

(Communication Interface Unit)

Used for V606 to communicate with each network.

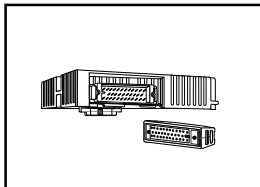

E-I/O (Extension I/O Unit)

Used as an external I/O unit for PLC. It has 16 inputs and 16 outputs.
(It cannot be used for V606, V606i and V608.)

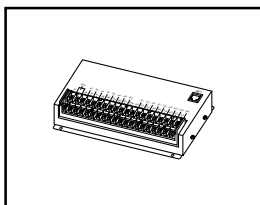

V-I/O (Serial Extension I/O)

Used as an external I/O unit for PLC. It has 16 inputs and 16 outputs.

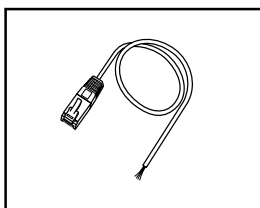

V6-BCD (Cable for Bar Code Reader) 3m

Connects V6 to a bar code reader.

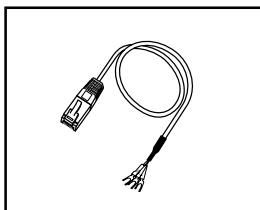

V6-MLT (Cable for Multi-Link 2 master station) 3m

A cable which is used for connecting the V6 master station and the V6 slave station in the Multi-Link 2 connection.

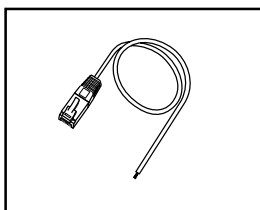

V6-TMP (Cable for Temperature Controller) 3m

Connects V6 to a temperature controller.

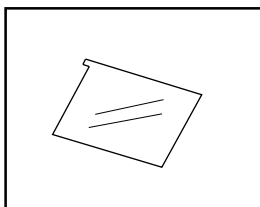

V6XX-GS [XX: 06 -> V606/V606i, 08 -> V608, 10 -> V610, 12 -> V612]

(Protection Sheet)

Protects the operation panel surface. Five sheets are included in one package.

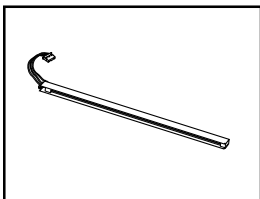

V6XXX-FL [XXX : 06C -> V606C, 06M -> V606M, 08C -> V608C, 10C -> V610C, 10T -> V610T, 10S -> V610S, 12C -> V612C, 12T -> V612T]

(Backlight for Replacement)

Placement backlight parts for V6 series.

4 Names of Components

Front Side of V606

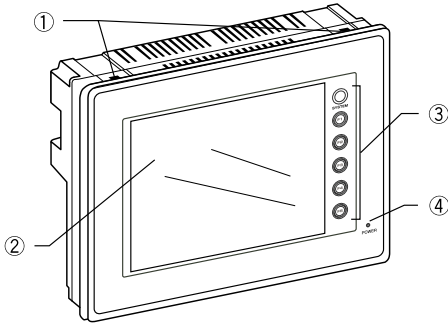

Rear Side of V606

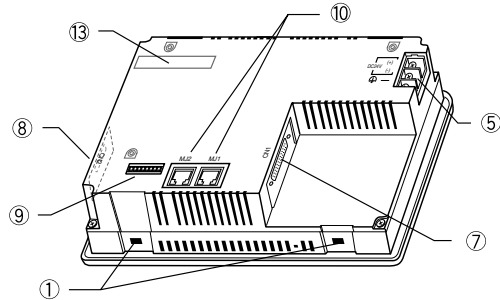

Front Side of V606i

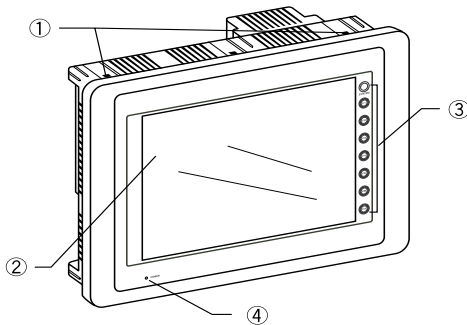

Rear Side of V606i

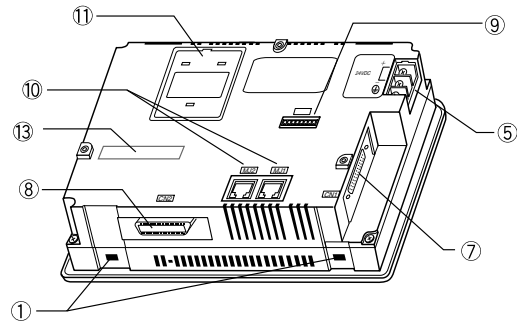

1. Mounting holes for fixtures
2. Display
3. Function keys (Refer to P1-49.)
4. Power lamp
5. DC input terminal of power supply
7. CN1: for PLC (RS-232C, RS-422)
8. CN2: for printer

9. Dip switches
10. MJ1, 2: for data transfer and for temperature controller and for bar-code reader and for CREC (option)
11. for V6EM/X (option)
13. for CU-XX/CUS-XX (option)

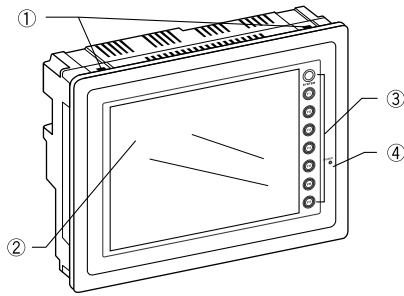
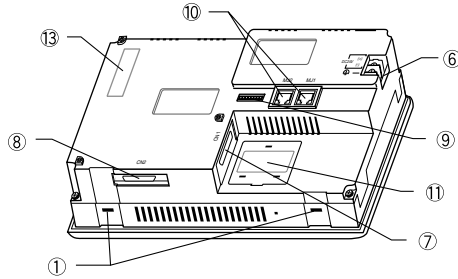
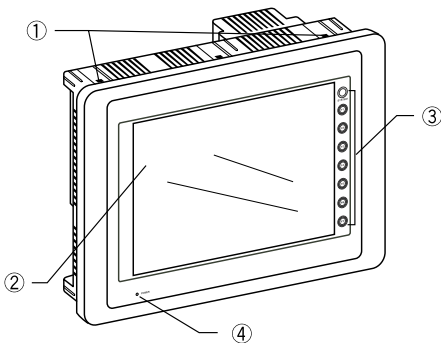
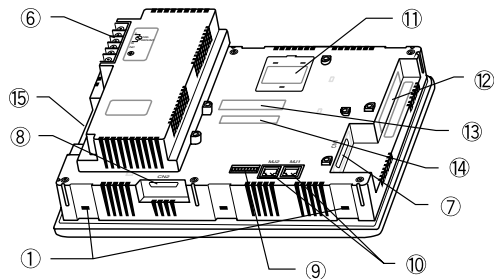
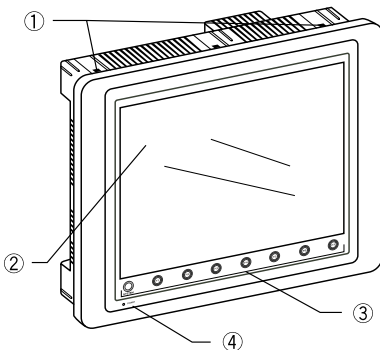
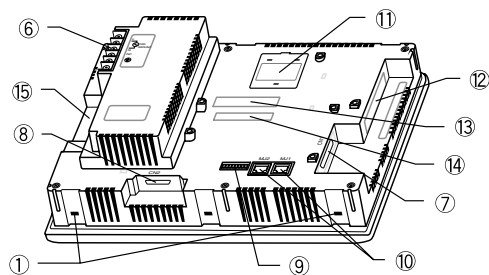
Front Side of V608**Rear Side of V608****Front Side of V610****Rear Side of V610****Front Side of V612****Rear Side of V612**

1. Mounting holes for fixtures
2. Display
3. Function keys (Refer to P1-49.)
4. Power lamp
6. AC / DC input terminal of power supply
7. CN1: for PLC (RS-232C, RS-422)
8. CN2: for printer
9. Dip switches

10. MJ1, 2: for data transfer and for temperature controller and for bar-code reader and for CREC (option)
11. for V6EM/X (option)
12. for video (option)
13. for CU-XX (option)
14. for E-I/O (option)
15. Card interface (option)

5 Dimensions and Panel Cut-out

Dimensions of V606

Unit : mm

Top View

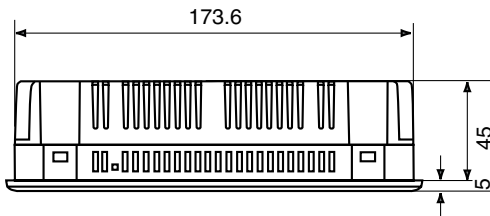

Rear View

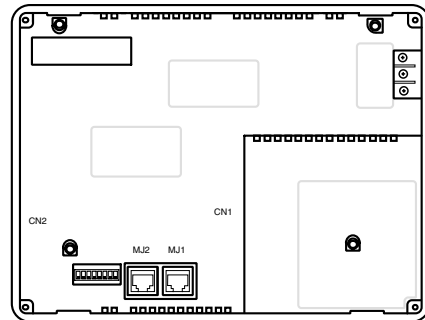

Front View

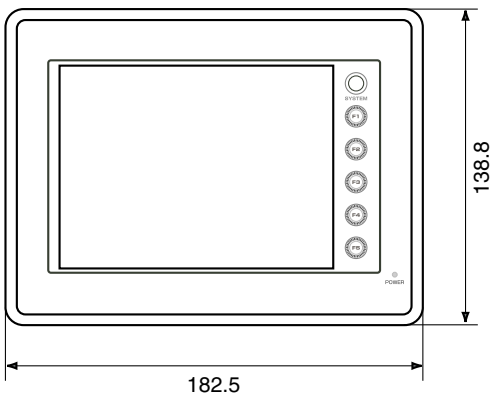

Side View

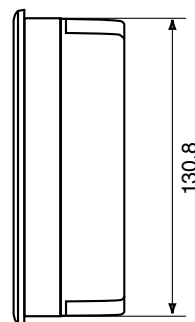

Panel Cut-out of V606

Unit : mm

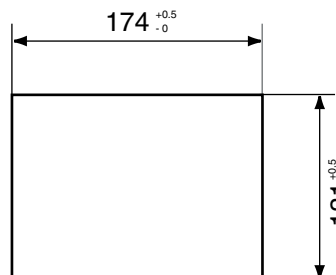

Dimensions of V606i

Unit : mm

○ Side View

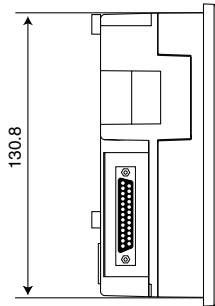

○ Front View

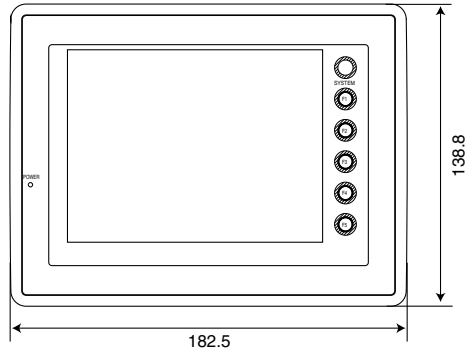

○ Rear View

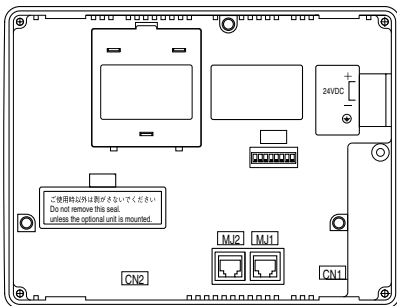

○ Bottom View

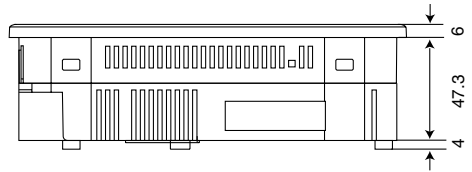

Panel Cut-out of V606i

Unit : mm

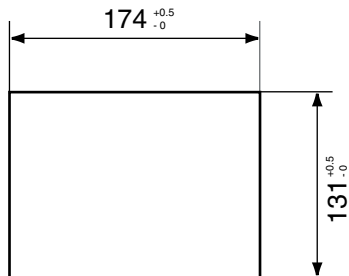

Dimensions of V608

Unit : mm

○ Top View

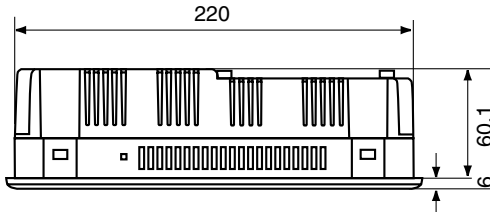

○ Rear View

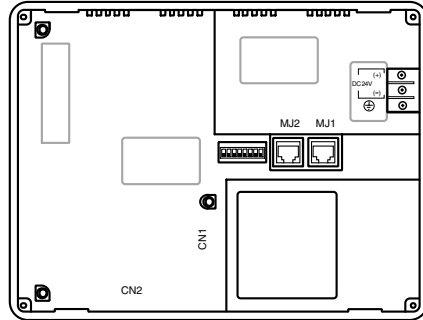

○ Front View

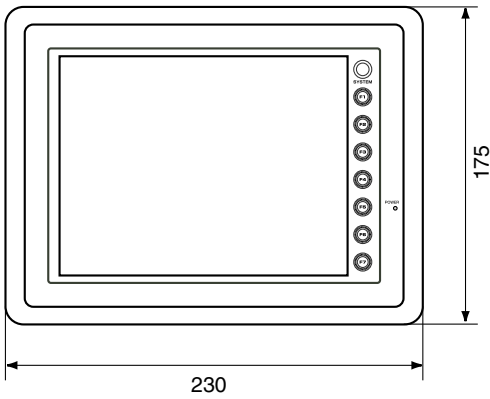

○ Side View

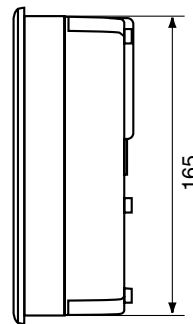

Panel Cut-out of V608

Unit : mm

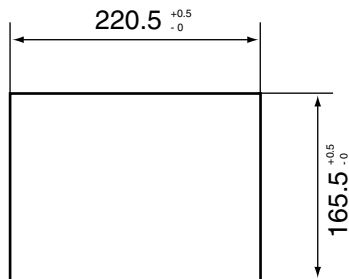

Dimensions of V610

Unit : mm

○ Top View

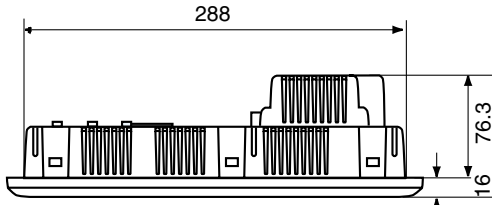

○ Rear View

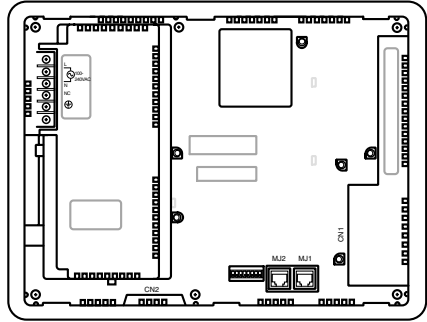

○ Front View

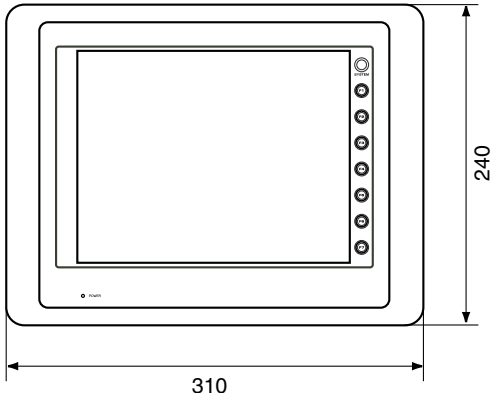

○ Side View

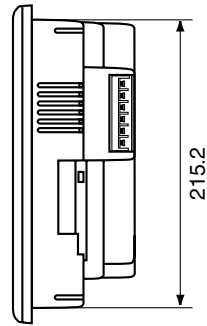

Panel Cut-out of V610

Unit : mm

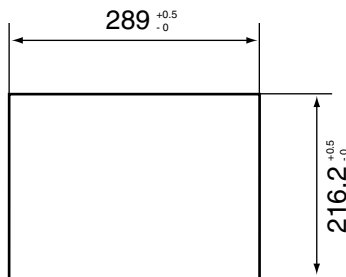

Dimensions of V612

Unit : mm

○ Top View

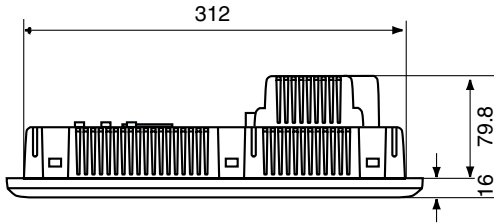

○ Rear View

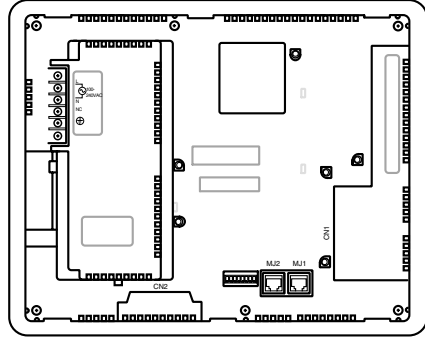

○ Front View

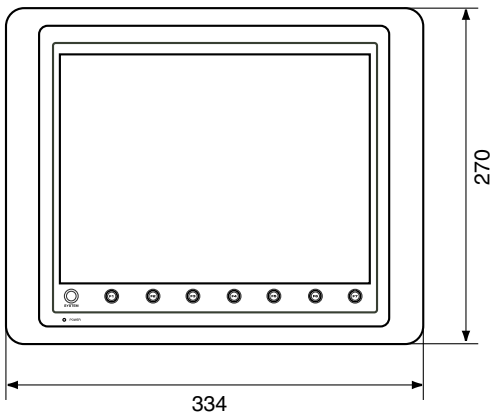

○ Side View

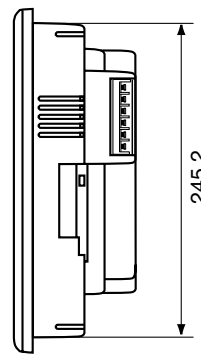

Panel Cut-out of V612

Unit : mm

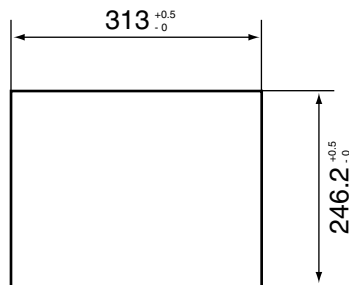

6 Mounting Procedure

Mounting Procedure

1. Cut out the mounting panel (Max. thick: 3.2 mm) to match the dimensions shown below.

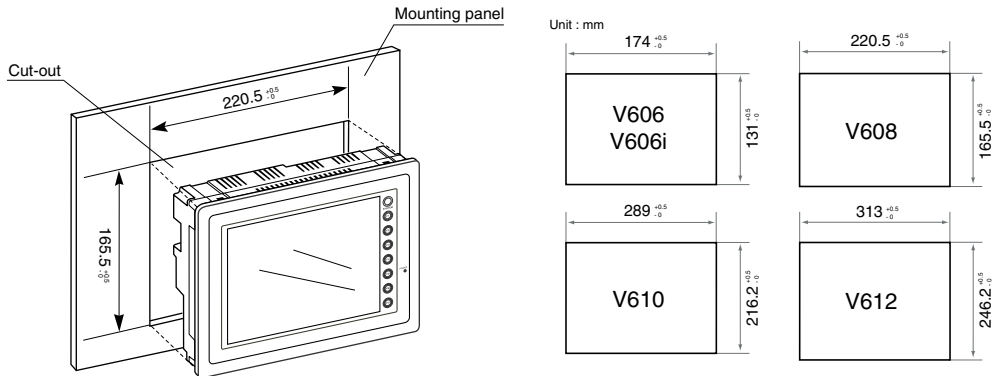

2. Insert the fixtures attached to V6 into the mounting holes on V6. Tighten them with the locking screws.

Number of the fixtures : 4 pcs

torque : V606/V606i/V608 0.3~0.5N·m (3~5kgf·cm)
: V610/V612 0.5~0.7N·m (5~7kgf·cm)

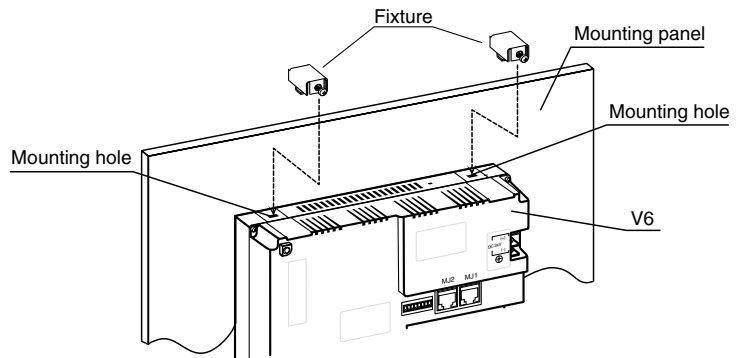
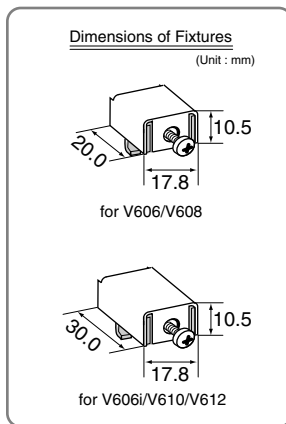

3. Mount unit flash with mounting plate with gasket tight against outside of mounting unit.

Mounting Angle

The unit (V6) shall be installed within the angle of 0 to 135 degrees as shown below.

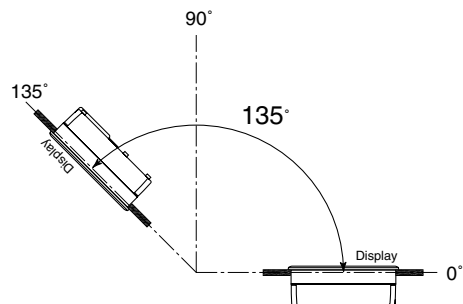

7 Wiring

Electrical Wiring

○Connects the cable for power supply to TB1 on the rear side of V6.

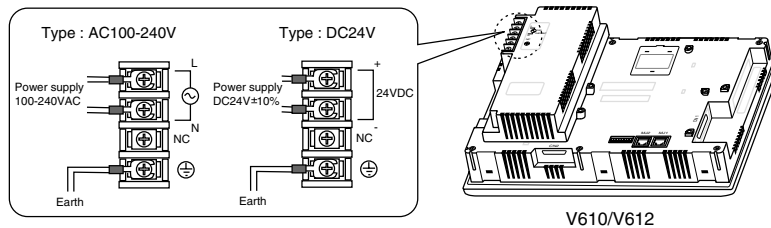
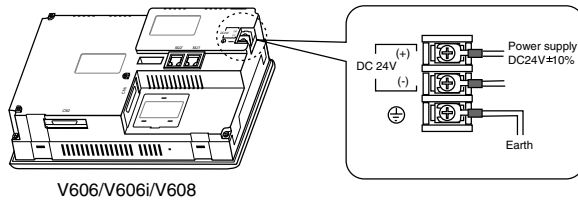

○When TB1 is used for wiring, refer to the following table.

Type	Screw	Screw Size	Torque (N·m)	Clamp Terminal (Unit : mm)
V606/V606i/V608		M3.5	0.5 (5kgf·cm)	7.1MAX 7.1MAX
V610/V612		M3	0.5 (5kgf·cm)	7.9MAX 7.9MAX

○The power source used must be within the allowable voltage fluctuation.

○Use a power source with low noise between the cables or ground and the cable.

○Use as thick a power cable as possible to minimize any drop in voltage.

○Keep cables of 100V AC and 24V DC sufficiently away from high-voltage, large-current cables.

Notes on Usage of V610/612 100-240V AC Specifications

○Generally, an isolating transformer improves noise resistance. However, if the display unit is far away from the secondary port of the transformer and noise gets mixed in, an isolating transformer becomes unnecessary.

○If any power voltage fluctuation caused by noise is expected, it is recommended that a voltage stabilizer (effective in noise resistance) be used.

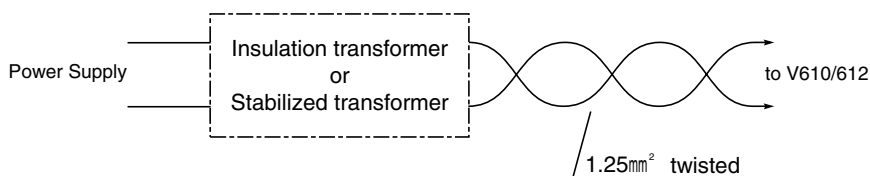

Grounding



This equipment must be earthed.

- An independent earth pole shall be used for MONITOUCH.
(The level of grounding resistance should be less than 100 Ω.)
- Use a cable which has a nominal cross section of more than 2mm² for grounding.
- Grounding point shall be near the MONITOUCH to shorten the distance of grounding wires.

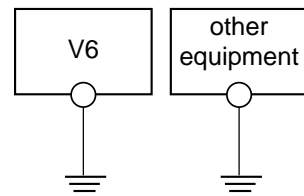

Grounding resistance : less than 100Ω

Wiring for Communication

- Never place the communication cable with electric circuits.
- Never bundle these cables together with other wires in ducts or electric boxes using cord locks. Although it is tempting to bundle all the cables neatly together, this does not necessarily lead to a noise-resistant configuration.
- It is recommended that the communication cable be independently wired.

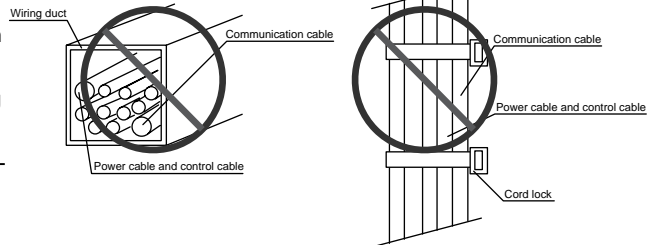

8 Specifications

General Specifications

Item		Type	V606	V606i	V608
Power Supply	Rated Voltage		24V DC		
	Permissible Range of Voltage		24V±10% DC		
	Permissible Momentary Power Failure		10ms or less		
	Demand		10W or less		20W or less
	Rushed Electric Current		15A 1ms		15A 1.5ms
	With-stand voltage		DC external terminals to FG : 500V AC per min.		
Insulation Resistance			500V DC, 10MΩor more		
Physical Environment	Ambient Temperature		0°C~+50°C(V610 STN Color : 0°C~+40°C)		
	Storage Ambient Temperature		-10°C~+60°C		
	Ambient Humidity		85% RH or less (without dew condensation)		
	Dust		No conductive dust		
	Solvent Resistance		No cutting oil or no organic solvent to cling to the unit		
	Corrosive Gas		No corrosive gas		
Mechanical Working Conditions	Vibration Resistance		Vibration frequency: 10~150Hz, Acceleration: 9.8m/s ² (1.0G) Single amplitude: 0.075mm, 3 directions of X, Y and Z: one hour		
	Shock Resistance		Pulse shape: Sine half wave, Peak acceleration: 147m/s ² (15G), 3 directions of X, Y and Z: six times		
Electrical Working Conditions	Noise Resistance		Noise voltage: 1500Vp-p, noise width: 1μs		
	Static Electricity Discharge Resistance		Contact: 6kV , Air: 8kV		
Mounting Conditions	Grounding		Grounding resistance: less than 100Ω		
	Structure		Protection structure: front panel complies with IP65 (when using gasket) rear panel complies with IP20 Form: in a body Mounting procedure: inserted in a mounting panel		
	Cooling System		Cooling naturally		
	Weight		Approx. 0.8kg	Approx. 0.8kg	Approx. 1.1kg
	Dimensions W X H X D (mm)		182.5 X 138.8 X 50	182.5 X138.8 X 57.3*1	230 X 175 X 66.1
	Panel Cut-out (mm)		174 ^{+0.5} ₋₀ X 131 ^{+0.5} ₋₀	174 ^{+0.5} ₋₀ X 131 ^{+0.5} ₋₀	220.5 ^{+0.5} ₋₀ X 165.5 ^{+0.5} ₋₀
Case Color		GREY	BLACK*2	GREY	
Material		PC/ABS	PC/PS	PC/ABS	

*1 including 4mm, the size of boss for communication unit

*2 equivalent to the Munsell color system N-2.0

V610		V612	
AC Power Supply	DC Power Supply	AC Power Supply	DC Power Supply
100/240V AC	24V DC	100/240V AC	24V DC
85-265V AC (47-440Hz)	24V \pm 10% DC	85-265V AC (47-440Hz)	24V \pm 10% DC
20ms or less	10ms or less	20ms or less	10ms or less
45VA or less	25W or less	50VA or less	25W or less
20A : 100V AC 30A : 200V AC	30A 6ms	20A : 100V AC 30A : 200V AC	30A 6ms
AC external terminals to FG : 1500V AC per min.	DC external terminals to FG : 500V AC per min.	AC external terminals to FG : 1500V AC per min.	DC external terminals to FG : 500V AC per min.
500V DC, 10M Ω or more			
0°C ~ +50°C (V610 STN Color : 0°C ~ +40°C)			
-10°C ~ +60°C			
85% RH or less (without dew condensation)			
No conductive dust			
No cutting oil or no organic solvent to cling to the unit			
No corrosive gas			
Vibration frequency: 10~150Hz, Acceleration: 9.8m/s ² (1.0G) Single amplitude: 0.075mm, 3 directions of X, Y and Z: one hour			
Pulse shape: Sine half wave, Peak acceleration: 147m/s ² (15G), 3 directions of X, Y and Z: six times			
Noise voltage: 1500Vp-p, noise width: 1 μ s			
Contact: 6kV , Air: 8kV			
Grounding resistance: less than 100 Ω			
Protection structure: front panel complies with IP65 (when gasket using) rear panel complies with IP20 Form: in a body Mounting procedure: inserted in a mounting panel			
Cooling naturally			
Approx. 2.5kg		Approx. 3.0kg	
310 X 240 X 92.3		334 X 270 X 95.8	
289 ^{+0.5} ₀ X 216.2 ^{+0.5} ₀		313 ^{+0.5} ₀ X 246.2 ^{+0.5} ₀	
GREY			
PC/ABS			

Display Specifications

Item \ Type	V606M	V606C	V606iM	V606iC	V606iT	V608C
Display Device	STN Monochrome LCD	STN Color LCD	STN Monochrome LCD	STN Color LCD	TFT Color LCD	STN Color LCD
Resolution W X H (dots)	320 X 240					640 X 480
Dot Pitch W X H (mm)	0.36 X 0.36	0.12 X 0.36	0.36 X 0.36	0.12 X 0.36	0.36 X 0.36	0.082X0.246
Effective Display Area W X H (mm)	115.2 X 86.4 (5.7 inches)					157.4 X 118.1 (7.7 inches)
Color	Monochrome 8 gradation + blinking	16 colors + blinking	Monochrome 8 gradation + blinking	16 colors + blinking		128 colors + blinking 16 colors
Back-light	Cold cathode rectifier (which can be exchanged by a user except for V606i)					
Contrast Adjustment	By function switches (only in case of STN type)					
Back-light Average Life*	Approx. 40,000h		Approx. 50,000h			Approx. 40,000h
Power Lamp	The lamp is lit when the power is supplied.					

Item \ Type	V610C	V610T	V610S	V612C	V612T
Display Device	STN Color LCD	TFT Color LCD		STN Color LCD	TFT Color LCD
Resolution W X H (dots)	640 X 480		800 X 600		
Dot Pitch W X H (mm)	0.11 X 0.33	0.33 X 0.33	0.264 X 0.264	0.1025 X 0.3075	0.3075 X 0.3075
Effective Display Area W X H (mm)	211.2 X 158.4 (10.4 inches)			246.0 X 184.5 (12.1 inches)	
Color	128 colors + blinking 16 colors				
Back-light	Cold cathode rectifier (which can be exchanged by a user)				
Contrast Adjustment	By function switches (only in case of STN type)				
Back-light Average Life*	Approx. 25,000h				
Power Lamp	The lamp is lit when the power is supplied.				

* When the normal temperature is 25°C, and the surface luminance of the display is 50% of the default.

Display Function Specifications (All the V6 series)

Item	Specifications					
Display Language	Japanese	Eng./W. Europe	Chinese	Chinese (simplified)	Korean	
Characters	1/4-size, 1-byte	ANK code	Latin 1	ASCII code	ASCII code	ASCII code
	2-byte (16-dot)	JIS 1st and 2nd	—	Chinese	Chinese (simplified)	Hangul (without Kanji)
	2-byte (32-dot)	JIS 1st	—			
Size of Characters	1/4-size : 8 X 8 dots 1-byte : 8 X 16 dots 2-byte : 16 X 16 dots or 32 X 32 dots Enlarge : W, 1-8 H, 1-8					
Number of Characters	Resolution	320 X 240		640 X 480		800 X 600
	1/4-size	40 columns X 30 lines		80 columns X 60 lines		100 columns X 75 lines
	1-byte	40 columns X 15 lines		80 columns X 30 lines		100 columns X 37 lines
	2-byte	20 columns X 15 lines		40 columns X 30 lines		50 columns X 37 lines
Property of Characters	Display property : normal, reverse, blinking, bold, shadow Color : 128 colors + blinking 16 colors / 16 colors + blinking / Monochrome 8 gradation + blinking					
Kind of Drawing	Lines : line, continuous lines, box, parallelogram, polygon Circles : circle, arc, sector, ellipse, elliptical arc, elliptical sector Others : tile patterns					
Property of Drawing	Type of lines : 6 types (fine, thick, dot, chain, broken, two-dot chain) Tile patterns : 16 types (incl. user-definable 8 types) Display property : normal, reverse, blinking Display color : 128 colors + blinking 16 colors / 16 colors + blinking / Monochrome 8 gradation + blinking Color specification : foreground, background, boundaries (line)					

Function Performance Specifications (All the v6 series)

Item	Specifications	
Screens	Max. 1024	
Screen Memory	FP-ROM (flash ROM), Approx. 2,816kbytes ^{*1} (different from the language)	
Switches	768 per screen (192 per screen for V606/V606i)	
Actions of Switch	Set, reset, momentary, alternate, to light (possible to press a function switch and a display switch at the same time) (Matrix type : 2 switches on the display can be pressed at the same time)	
Lamps	Reverse, blinking, exchange of graphics 768 per screen (192 per screen for V606/V606i)	
Graphs	Pie, bar, panel meter and closed area graph can be displayed without limit. Total capacity per screen: within 128kB ^{*2} Statics and trend graphs: Max. 256 per layer ^{*3}	
Data Setting	Numerical Data Display	No limits, total capacity per screen: within 128 kB ^{*2}
	Character Display	No limits, total capacity per screen: within 128 kB ^{*2}
	Message Display	Resolution : 320X240, Max. 40 characters 640X480, Max. 80 characters 800X600, Max. 100 characters No limits, total capacity per screen: within 128 kB ^{*2}
Messages	6144 lines	
Sampling	Sampling display of buffer data (constant sample, bit synchronize, bit sample, relay sample, alarm function)	
Multi-Overlaps	Max. 1024	
Data Blocks	Max. 1024	
Graphic Libraries	Max. 2560	
Patterns	Max. 1024	
Macro Blocks	Max. 1024	
Page Blocks	Max. 1024	
Direct Blocks	Max. 1024	
Screen Blocks	Max. 1024	
Temperature Control Network Table	Max. 32	
Calendar	provided	
Hard-Copy	provided	
Buzzer	provided, 2 types (intermittent short and long sounds)	
Back-light Auto OFF Function	ON at all time, specified freely	
Self-diagnostic Function	Self-test function of switches Check function of communication parameter setting Check function of communication	

*1 If the hardware version is the following version, or V606/V606i is used, the screen memory is approx. 760kbytes.

Analog type: V612T→A~E, V612C→A~D, V610S→A~E, V610T→A~F, V610C→A~E, V608C→A~C
Matrix type : V612T→only D, V612C→only C, V610C→only D

*2 The number of the setting memory is limited to 256 per screen for V606/V606i, and 1024 per screen for other models.

*3 Layer : 4 per screen (base + 3 overlaps) In case of V606/V606i, it is limited to 256 per screen.

Touch Panel Specifications (All the V6 series)

Item	Specifications
Switch Resolution	Analog type, 1024(W) X 1024(H) Matrix type, V612 : 50(W) X 30(H) pcs V610 : 40(W) X 24(H) pcs V606/V606i : 20(W) X 12(H) pcs
Form	Resistance film form
Life of Touch Panel	Use of one million times or more

Function Switch Specifications (All the V6 series)

Item	Specifications
Number of Switches	8 (6 for V606/V606i)
Type of Switch	Pressure sensitive switches
Life of Switch	Use of one million times or more

Interface Specifications (All the V6 series)

Item	Specifications
Serial Interface for connecting PLC (D-sub 25 pins, female)	RS-232C, RS-422/485 Asynchronous type Data length: 7, 8 bits Parity: even, odd, none Stop bit: 1, 2 bits Baud rate: 4800, 9600, 19200, 38400, 57600, 76800, 115000bps (115200bps is invalid for V606/V606i.)
Serial Interface 1 and 2 for transferring data /other external (modular jack, 8 pins)	RS-232C, RS-422/485 (2-wire connection) CREC, Bar code, V-I/O, Multi-link 2, Temperature control network, V-Link
Printer Interface	Complies with centronics, half pitch 36 pins (for PC98x1) NEC : PR201 EPSON : compatibles with ESC/P24-84 or later HP : PCL Level 3 CBM292/293 printer (The screen copy cannot be printed out.)

Drawing Environment (All the V6 series)

Item	Specifications
Drawing Method	Exclusive drawing software
Drawing Tool	Name of exclusive drawing software : V-SFT Personal computer : Pentium II 450 MHz or above recommended OS : Microsoft Windows 98/Me/NT version 4.0/2000/XP Capacity of hard disk required : free area of approx. 460MB or more (for minimum installation: approx. 105 Mbyte) Display : resolution of 640 X 480 or more (800 X 600 is recommended)

9 Serial Connector (CN1)

CN1 is used for communicating between a PLC and a V6 (RS-232C, RS-422/485).

Serial Connector (CN1)

The pin arrangement of serial connector is as follows:

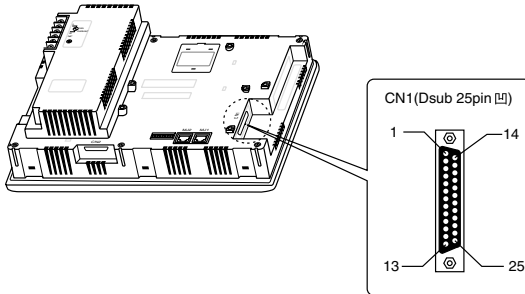

Pin No.	Signal	Contents
1	FG	Frame ground
2	SD	RS-232C send data
3	RD	RS-232C receive data
4	RS	RS-232C RS request to send
5	CS	RS-232C CS clear to send
6		Not used
7	SG	Signal ground
8		Not used
9	+5V	Use prohibited
10	0V	Use prohibited
11		Not used
12	+SD	RS-422 send data (+)
13	-SD	RS-422 send data (-)
14	+RS	RS-422 RS send data (+)
15		Not used
16		Not used
17	-RS	RS-422 RS send data (-)
18	-CS	RS-422 CS receive data (-)
19	+CS	RS-422 CS receive data (+)
20		Not used
21		Not used
22		Not used
23		Not used
24	+RD	RS-422 receive data (+)
25	-RD	RS-422 receive data (-)

Communication Cable of RS-232C/RS-422

RS-232C

○In case of RS-232C, SD and SG, and RD and SG form a pair.

○Connect the shielded cable to pin No. 1 or the connector case cover.

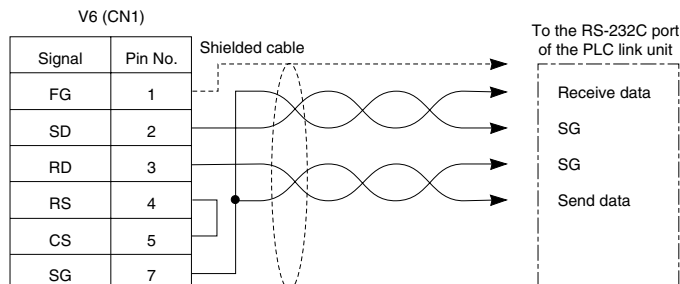

RS-422

- In case of RS-422, +SD and -SD, and +RD and -RD form a pair.
- Use SG if possible.
- Connect the shielded cable to pin No. 1 or the connector case cover.
- Use TC485 which is the optional equipment made by Hakko Electronics Co., Ltd. in case of using terminal blocks in RS-422/485 connection.
- Specify terminal resistance by the dip switches on V6. (Refer to the next page.)

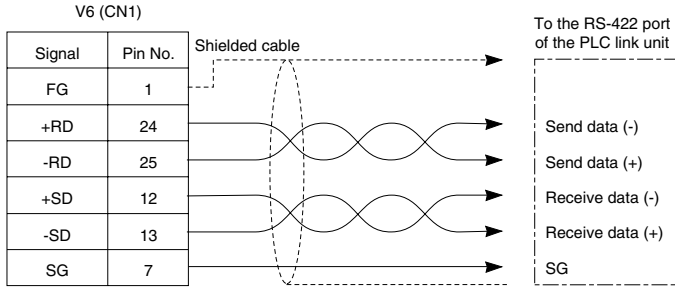

Terminal Blocks of RS-422/485

- Connect TC485 (Terminal Converter) which is the optional equipment made by Hakko Electronics Co., Ltd. to V6 via the serial connector on V6 (CN1) in case of using terminal blocks in RS-422/485 connection.
- The RS-422 signal wiring of TC485 is connected to the serial connector (CN1).

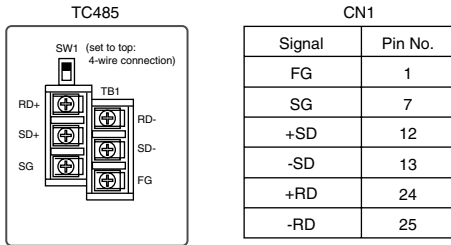
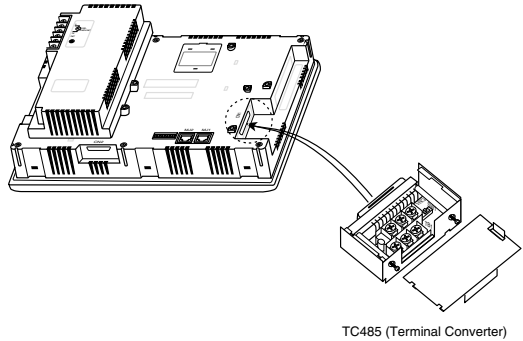

- Specify 4-wire connection or 2-wire connection by the dip switch on TC485 (SW1). (set to top: 4-wire connection)

10 Setting of Dip Switches

Setting of Dip Switches (DIPSW)

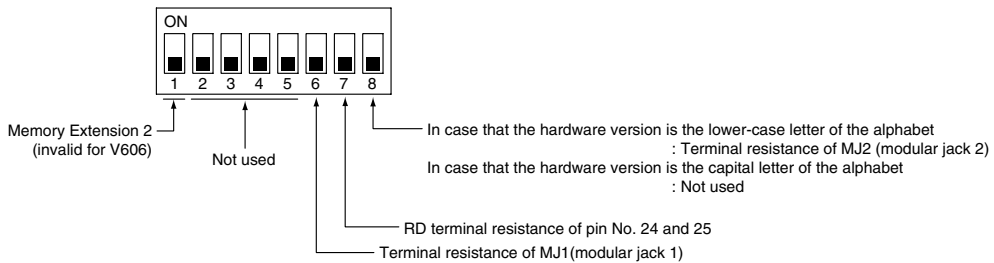

- Keep DIPSW 2, 3, 4 and 5 (not used) OFF.
- Setting of Memory Extension 2 (This dip switch is invalid for V606. Keep DIPSW 1 OFF.)
 - Set DIPSW 1 ON in case of selecting "Memory Extension 2."
(Refer to "Operation Instruction for V6EM/4-V6EM/4i (EPROM cassette).")
- Setting of Terminal Resistance depends on the hardware version of the unit.
Hardware version is mentioned in the "LOT No:" column on the back of the unit.

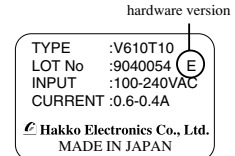

- ◇ In case that the hardware version is the lower-case letter of the alphabet.
 - Set DIPSW 7 ON in case of connecting with CN1 by connection of RS-422/485.
 - Set DIPSW 6 (DIPSW8) ON in case of connecting with Modular Jack 1/2 by the connection as below.
 - Multi-link2 communication (master)
 - Temperature controller communication by connection of RS-485
 - Card Recorder : CREC (option) is used
 - Serial Extension I/O : V-I/O (option) is used
 - Terminal V6 connected with V-Link by connection of RS-485
- ◇ In case that the hardware version is the capital letter of the alphabet
 - Set DIPSW 7 ON in case of connecting with CN1 by connection of RS-422/485.
 - Set DIPSW 6 ON in case of connecting with Modular Jack 1 by the connection as below.
 - Multi-link2 communication (master)
 - Temperature controller communication by connection of RS-485
 - Card Recorder : CREC (option) is used
 - Serial Extension I/O : V-I/O (option) is used
 - Terminal V6 connected with V-Link by connection of RS-485
 - The terminal resistance of MJ 2 is always ON.

11 Modular Jack 1 & 2

Modular Jack 1 & 2 (MJ1/2)

The right diagram is the pin arrangement and the signal name of modular jack 1 & 2.

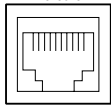
MJ1/2	Pin No.	Signal	Contents
	1	+SD/RD	RS-485 + data
	2	-SD/RD	RS-485 - data
	3	+5V	Output power supply Max. 150mA
	4	+5V	
	5	0V	Signal ground
	6	0V	
	7	RD	RS-232C receive data
	8	SD	RS-232C send data

Setting of Modular Jack 1 & 2 (MJ1/MJ2)

- Specify the use of MJ1/MJ2 by the software (V-SFTE).
- Select [System Setting] from [Item], and click [Others]. The [Others] dialog is displayed. The setting items of [Modular Jack 1] and [Modular Jack 2] in the [P2] menu are as follows.

Modular Jack 1	Modular Jack 2
[Editor port]	[Not used]
[Memory Card]	[Memory Card]
[Barcode]	[Barcode]
[V-I/O]	[V-I/O]
[Multi-Link]*1 *2	[Multi-Link]*1 *2
[Temp. CTRL Net]*2	[Temp. CTRL Net]*2
[V-Link]*2	[V-Link]*2
[Touch Switch]*3	[Touch Switch]*3
[Ladder Tool]	[Ladder Tool]
[Serial Printer]	[Serial Printer]

It is impossible to select both [Multi-Link] and [Temp. CTRL Net] in each setting of modular jack.

- *1 It is possible to select this item when [Multi-Link 2] is selected for [Connection] and [Local Port] is set to [1] in the [Comm. Parameter] dialog.
- *2 [Multi Link 2 (master)] and [Temperature Control Network] and [V-Link] are available in the following hardware version or later of V6. As for V606/V606i, any version can be used.
 - Analog type : V612T→D V612C→C V610S→D V610T→D V610C→D V608C→F
 - Matrix type : All version
- *3 As for [Touch Switch], refer to the "Analog RGB Input" manual.

Editor Transferring

- Use modular jack 1 (MJ1) in case of editor transferring.
- When [Editor port] is selected for [Modular Jack 1] in the [P2] menu, it is also possible to transfer the data while running, because the auto change of the local mode and the run mode is valid. When [Editor port] is selected, on-line editing and the simulation mode are also available.
- When the item other than [Editor port] is selected for [Modular Jack 1] in the [P2] menu, be sure to transfer the data by the software in the local mode. On-line editing and the simulation mode are not available.
- When the data is transferred by software, use the cable for data transferring which is the optional equipment made by Hakko Electronics Co., Ltd. (V6-CP: 3m) to connect V6 to a personal computer.

12 Bar Code Reader Interface

○ It is possible to receive the signal from a bar code reader by connecting a bar code reader to V6 via the modular jack (MJ1/MJ2) of V6 series.

○ To connect a bar code reader to V6 via MJ1/MJ2, use the cable which is the optional equipment made by Hakko Electronics Co., Ltd. (V6-BCD).

Length : 3m

Accessory : Modular Plug

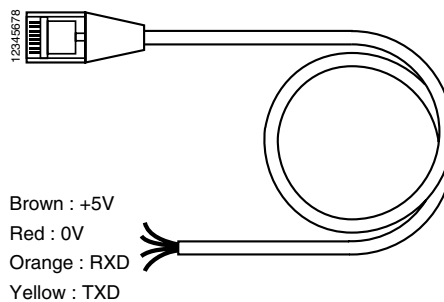

○ Notes on Connection

- In case of using the bar code reader which uses the CTS and RTS control, the bar code reader may not work normally without jumping RTS and CTS.
- The output power supply (+5V) is max. 150mA. (Refer to the preview page.)

○ When the bar code reader connected to V4 is used, connect it to V6 by the following cable.

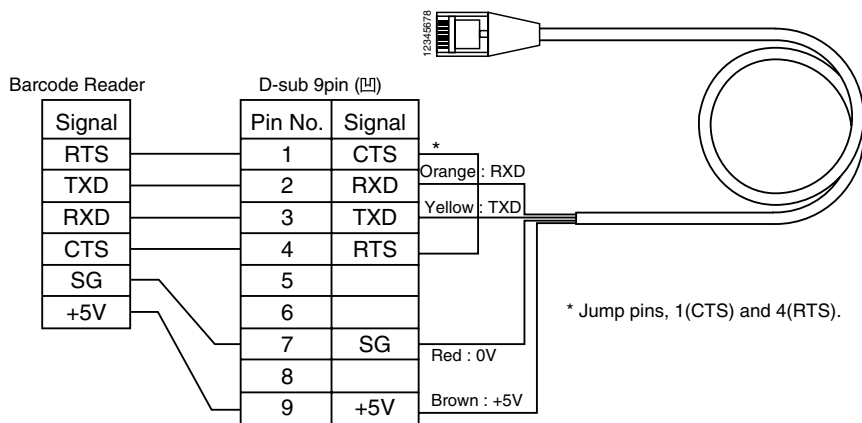

13 Printer Interface (CN2)

- When a printer is connected to V6 via the connector (CN2), it is possible to hard-copy the screen display of V6, the data sheet, or the sampling data.
- To connect a printer to V6, use the parallel interface cable of 36 pins which is optional equipment made by Hakko Electronics Co., Ltd. (V6-PT: 2.5m)
When using CBM292/293 printer, our printer cable "V6-PTCBM" is available.

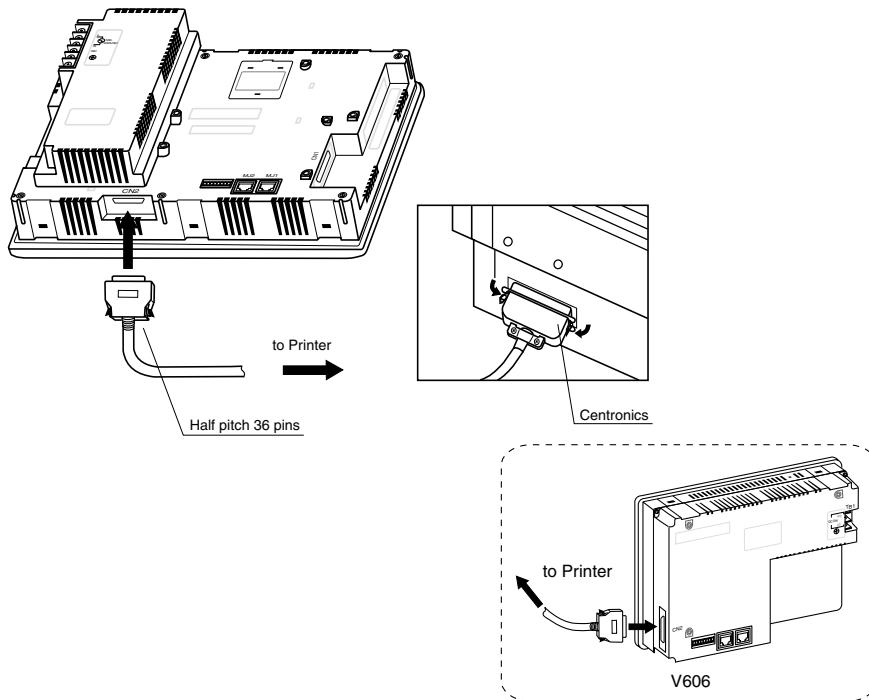

- Compatible Printer Control Code System and Printer Models

NEC	PC-PR201 series
EPSON	Compatibles with ESC/P24-84 or later
HP(HEWLETT PACKARD)	PCL Level 3
- CBM292/293 Line thermal panel printer made by CBM Corporation.
(The screen copy cannot be printed out.)

Note of Usage of SRAM Memory Card or SRAM Cassette ;

In case of connecting a printer to V6 series with a "REC-MCARD(Memory Card:SRAM)" or "V6EM/RS · V6EM/RSi (SRAM cassette)" at all times, be sure to turn off a printer at the same time when turning off V6. If a printer is not turned off when V6 is turned off, the voltage will circulate from the power supply line of a printer to make the power consumption of SRAM cassette's backup battery increase, and finally, the backup battery will consume drastically within a few months.

14 Video Interface

- When a video or a CCD camera is connected to the optional V6 which has a video interface, the image which is taken by a video or a camera is displayed directly in a screen of V6 series (only in case of V610T/S and V612T).
- Video Interface of V6: BNC

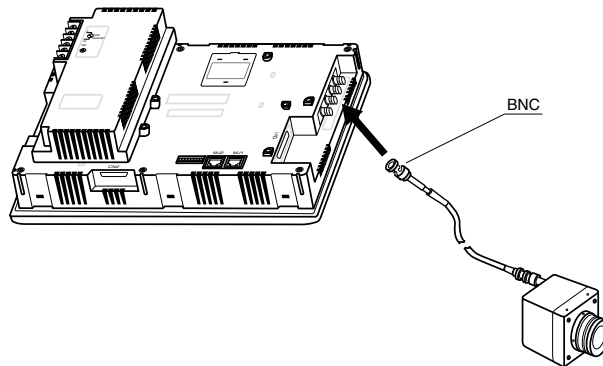

- Video Display Specifications
 - Display Color : 262,144 colors
 - Input Channel : 4 Channels
 - Signal Form : NTSC type, PAL type
 - Video Input : $1.0V_{p-p}$ 75 ohm unbalance
 - Display Size : 640 X 480, 640 X 240, 320 X 240, 160 X 120 dots (possible to change the size)
 - Color Adjustment : contrast (256 steps), brightness (256 steps), color gain (256 steps)

15 Connection

1 : 1 Link Communication

One V6 and one PLC are connected.

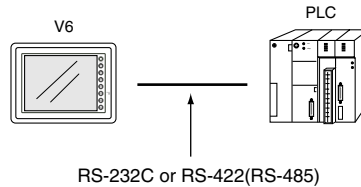

1 : n Link Communication (Multi-drop)

One V6 and multiple PLCs are connected. (n = 1 to 32)

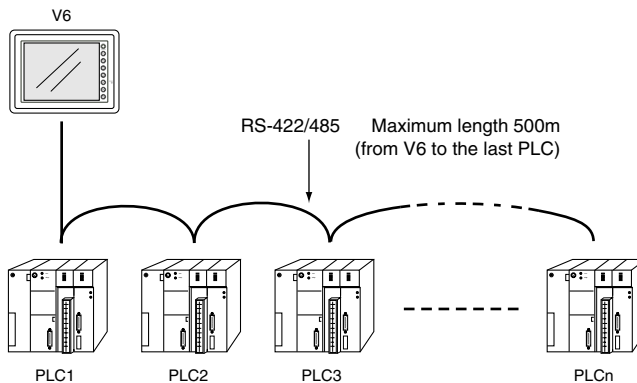

○ Available PLC for multi-drop communication

Manufacturer	Models
MITSUBISHI	AnA/N/U series, QnA series, QnH(Q)series, A link+Net10, FX series(A prt)
OMRON	SYSMAC C, CV, CQM1, CS1 DNA
SHARP	JW series, JW100/70H COM Port, JW20/30 COM Port
HITACHI	HIDIC-H
MATSUSHITA	MEWNET
YOKOGAWA	FA500, FA-M3, FA-M3R
YASKAWA	Memobus, CP9200SH/MP900
TOYOPUC	TOYOPUC
FUJI	MICREX-F series, FLEX-PC series, FLEX-PC COM
Koyo	SU/SG, SR-T
Allen-Bradley	PLC-5, SLC500, Micro Logix 1000
GE Fanuc	90 series
TOSHIBA	T series
SIEMENS	S7-200 PPI
SHINKO	SELMART
SAMSUNG	SPC series, N_plus, SECNET
KEYENCE	KZ series, KV series
LG	MASTER-K500 / K1000, MASTER-K xxxS CNET
FATEK	FACON FB series
IDEC	MICRO3
MODICON	Modbus RTU
TAIAN	TP02
	Universal Serial

○ Multi-drop Communication (RS-485)

Refer to the PLC manual of each manufacturer for connection.

<E.g.>

The following example describes how one V4 is connected to three PLCs made by MITSUBISHI.

See MITSUBISHI's manual for further details.

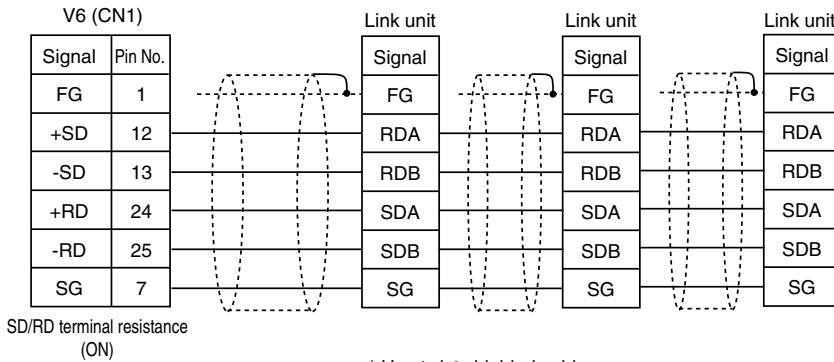

* Use twist shielded cable.

n : 1 Link Communication (Multi-link2)

Up to 4 units can be connected to one PLC.

* Between a PLC and the V6 master station is the same as those for 1:1 communication.

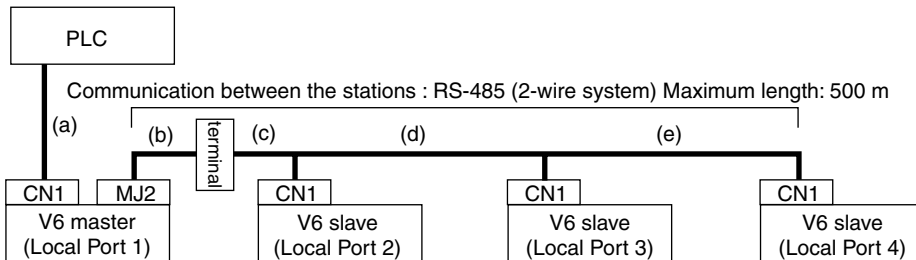

○ Available PLCs for multi-link2.

As of July 2001, the PLCs supported are as follows. All the PLCs which are usable for 1:1 communication will be supported.

For the I/F driver, the Multi-Link 2 is supported by the version of 1.100 or later and as for a V6 master station, make sure the hardware version of the unit is as follows.

As for V606/V606i, any version can be used.

- Analog type : V612T→D, V612C→C, V610S→D, V610T→D, V61C→D, V608C→F
- Matrix type : All version

* The Multi-Link 2 cannot be used with a communication interface unit such as CU-00, 01, 02, 03, 04, 05, CUS-00, 01.

* The Multi-Link 2 cannot be used with Temperature controll network.

<Type>	<Calendar>	<Type>	<Calendar>
MITSUBISHI : AnA/N/U series	Provided	GE Fanuc : 90 series	Not provided
MITSUBISHI : QnA series	Provided	GE Fanuc : 90 series(SNP-X)	Not provided
MITSUBISHI : ACPU Port	Provided	TOSHIBA : T series	Provided
MITSUBISHI : FX series	Depends on the model	SIEMENS : S5	Not provided
MITSUBISHI : QnACPU Port	Provided	SIEMENS : S7	Not provided
MITSUBISHI : QnHCPU Port (A)	Provided	SIEMENS : S5 V4	Not provided
MITSUBISHI : QnHCPU Port (Q)	Provided	SIEMENS : TI500/505	Provided
MITSUBISHI : FX series(A prt)	Provided	SIEMENS : TI500/505(V4)	Provided
MITSUBISHI : FX2N series	Depends on the model	SIEMENS : S5 PG port	Not provided
MITSUBISHI : FX1S series	Provided	SIEMENS : S7-300MPI(HMI ADP)	Not provided
OMRON : SYSMAC C	Depends on the model	SIEMENS : S7-300MPI(PC ADP)	Not provided
OMRON : SYSMAC CV	Provided	SAMSUNG : SPC series	Not provided
OMRON : SYSMAC CS1	Provided	SAMSUNG : N_plus	Provided
SHARP : JW series	Provided	SAMSUNG : SECNET	Depends on the model
SHARP : JW100/70H COM Port	Provided	KEYENCE : KZ series	Not provided
SHARP : JW20 COM Port	Provided	KEYENCE : KZ-A500 CPU Port	Provided
HITACHI : HIDIC-H	Provided	KEYENCE : KV series	Not provided
HITACHI : HIDIC-S10/2 alpha	Not provided	KEYENCE : KZ24/300 series CPU	Not provided
HITACHI : HIDIC-S10/ABS	Not provided	KEYENCE : KV10/24 series CPU	Not provided
MATSUSHITA : MEWNET	Depends on the model	KEYENCE : KV700 series CPU	Provided
YOKOGAWA : FA500	Provided	LG : MASTER-K10/60/200	Not provided
YOKOGAWA : FA-M3	Provided	LG : MASTER-K500/1000	Not provided
YOKOGAWA : FA-M3R	Provided	LG : LGMKX00S	Not provided
YASKAWA : Memobus	Depends on the model	LG : MASTER-KxxxS CNET	Not provided
YASKAWA : CP9200SH/MP900	Not provided	LG : GLOFACNET	Not provided
TOYOPUC	Provided	FANUC : Power Mate	Not provided
FUJI : MICREX-F series	Provided	FATEK AUTOMATION: FACON FB series	Provided
FUJI : MICREX-F series V4	Provided	IDEC : MICRO3	Provided
FUJI : FLEX-PC series	Provided	MODICON : Modbus RTU	Depends on the model
FUJI : FLEX-PC CPU	Provided	YAMATAKE : MX series	Provided
FUJI : FLEX-PC COM	Provided	TAIAN : TP02	Provided
FUJI : FLEX-PC(T)	Provided	SAIA : PCD	Provided
FUJI : FLEX-PC CPU(T)	Provided	MOELLER : PS4	Not provided
KOYO : SU/SG	Depends on the model	Telemecanique : TSX Micro	Not provided
KOYO : SR-T	Provided	Automationdirect : Direct LOGIC	Depends on the model
KOYO : SR-T(K prt)	Not provided	Automationdirect : Direct LOGIC(K-Sequence)	Depends on the model
KOYO : SU/SG(K-Sequence)	Depends on the model		
A.B : PLC-5	Not provided		
A.B : SLC500	Provided		
A.B : Micro Logix 1000	Not provided		

Up to 4 units can be connected to one PLC.

Use the terminal converter (TC485), the optional equipment made by Hakko Electronics Co., Ltd.

See Multi-link2 manual for further details.

* Wire the shielded FG only at the one of both sides so that they are not connected.

• Set the dip switch (SW1) of TC485 as 2-wire connection when the TC485 terminal converter is used.

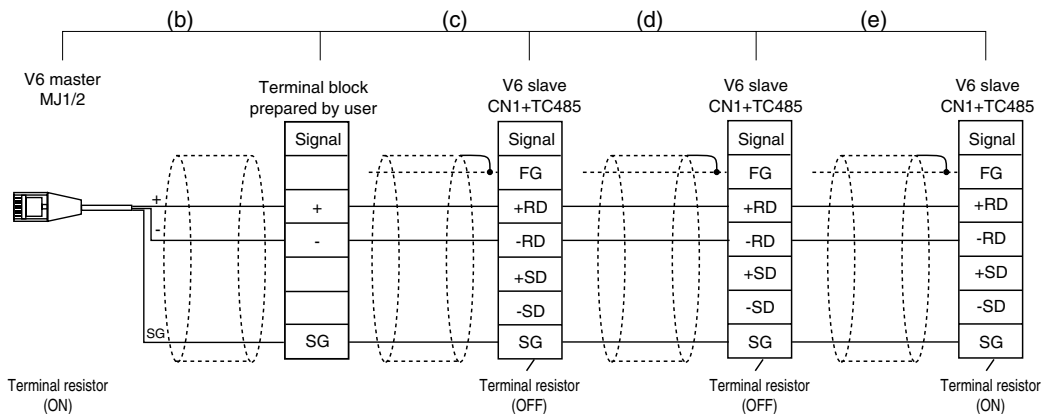

• Short-circuit between +RD and +SD, and -RD and -SD when the TC485 terminal converter is not used.

n : 1 Link Communication (Multi-link)

Multiple V6 and a PLC are connected. (n=1 to 32)

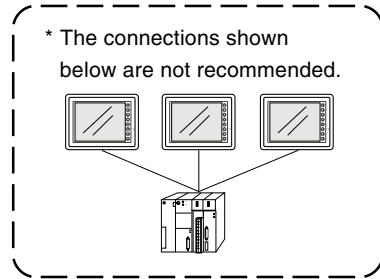
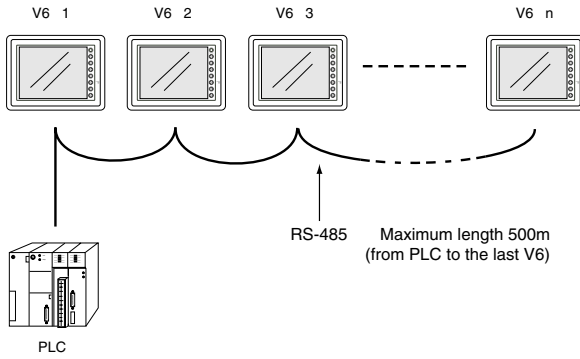

○ Available PLCs for multi-link

Manufacturer	Models
MITSUBISHI	AnA/N/U series, A link+Net10, FX series(A prt)
MITSUBISHI	QnA CPU port (with V-MDD)
OMRON	SYSMAC C, CV
SHARP	JW series, JW100/70H COM Port, JW20/30 COM Port
HITACHI	HIDIC-H
MATSUSHITA	MEWNET
YOKOGAWA	FA500, FA-M3, FA-M3R
YASKAWA	Memobus, CP9200SH/MP900
TOYOPUC	TOYOPUC
FUJI	MICREX-F series, FLEX-PC COM
TOSHIBA	T series
SIEMENS	S7-200 PPI
SHINKO	SELMART
SAMSUNG	SPC series, SECNET
LG	MASTER-K500 / K1000

- When multiple V6 are connected to a link unit of PLC, use the terminal converter (TC485), the optional equipment made by Hakko Electronics Co., Ltd. for RS-485 connection.
 - Set the dip switch (SW1) of TC485 as 2-wire connection when the TC485 terminal converter is used.

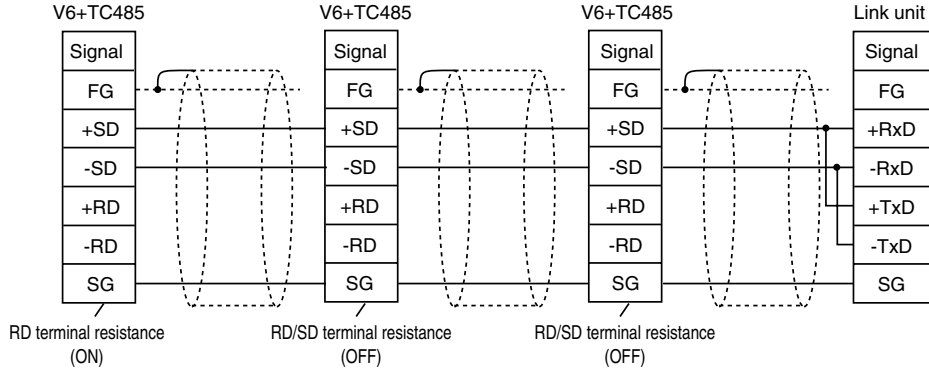

* Use twist shielded cable.

- Short-circuit between +RD and +SD, and -RD and -SD when the TC485 terminal converter is not used.

- When multiple V6 are connected directly to MITSUBISHI's QCPU port, the optional equipment, GD-MDD2 is required.
 - Set the dip switch (SW1) of TC485 as 2-wire connection when the TC485 terminal converter is used.

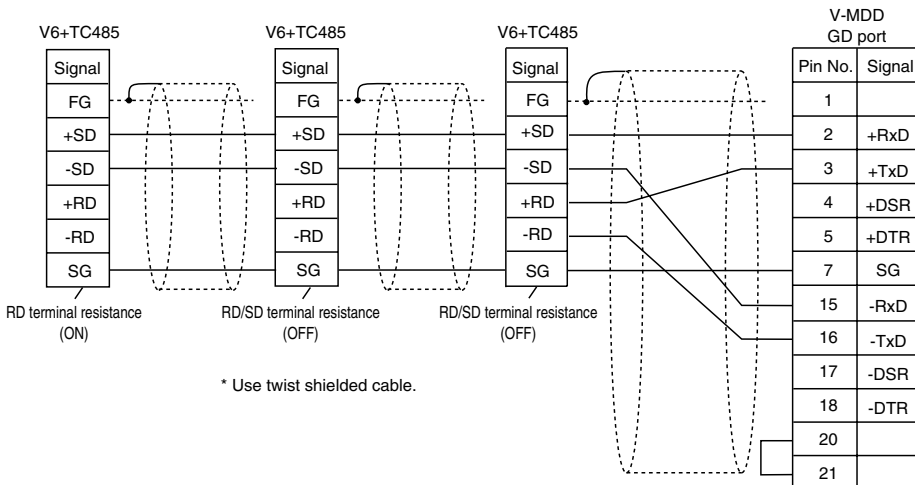

* Use twist shielded cable.

- Short-circuit between +RD and +SD, and -RD and -SD when the TC485 terminal converter is not used.

16 Operation of V6 Main Menu

When the power of V6 is turned on for the first time, the screen on the below left is displayed. After transferring the screen data to V6, the following "Main Menu" is displayed.

When power is turned on for the first time:



"Main Menu" after trasferring data

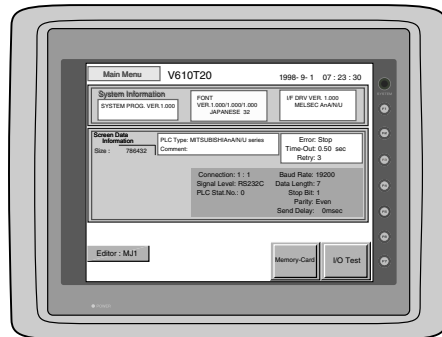

If the screen data has been already transferred to V6, press the [SYSTEM] switch, then press the [F1] switch. The [Main Menu] is displayed.

the [SYSTEM] switch

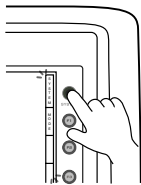

the [F1] switch

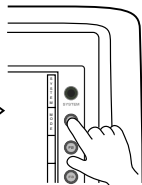

The "Main Menu" is displayed.

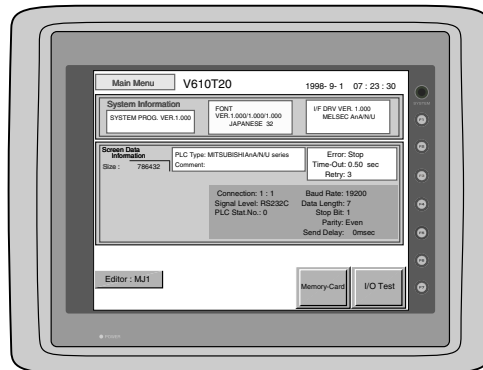

Main Menu

The "Main Menu" is the system menu for transferring the data between a personal computer and V6. When the screen data is transferred from a personal computer to V6, the "Main Menu" must be displayed. (If [Editor port] is selected for [Modular Jack 1] in the [P2] menu of the editing software or the on-line editing is executed, it is not necessary to display the "Main Menu".

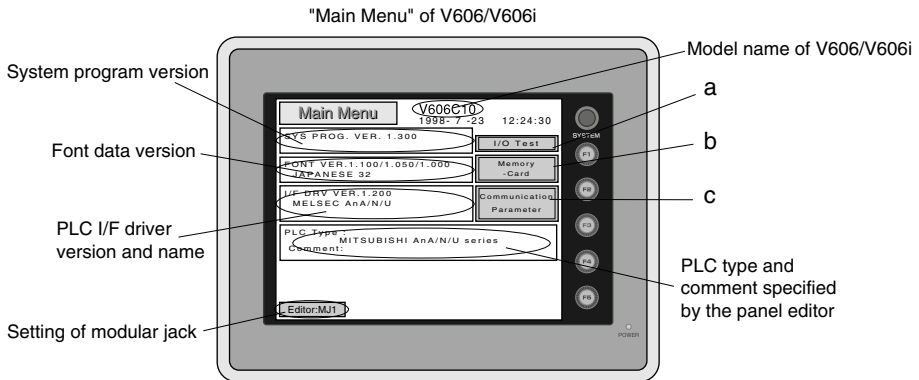
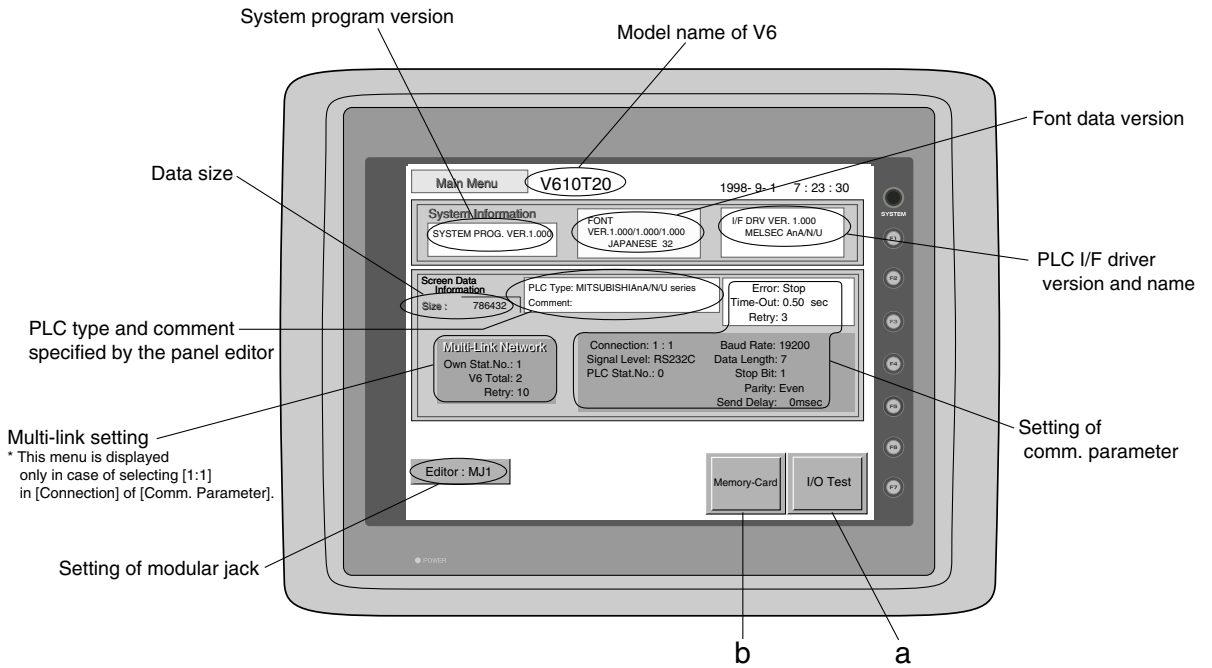

* In case of V606/V606i, when the "Communication Parameter" switch on the "Main Menu" is pressed, the following "Comm. Param." is displayed.

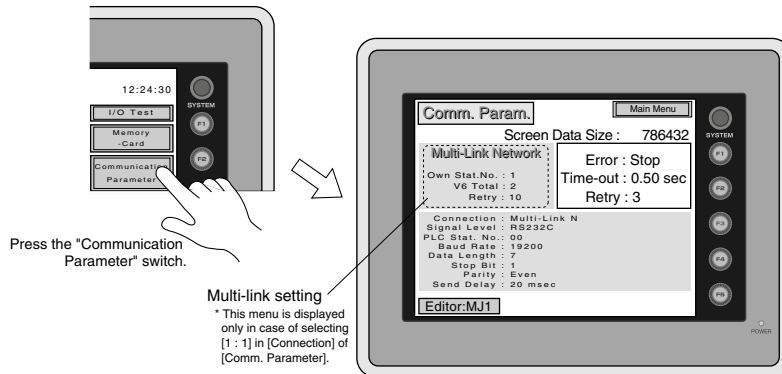

I/O Test

When the switch 'A' on the "Main Menu" is pressed, the following "I/O Test" is displayed. This is the test menu to check only V6 hardware.

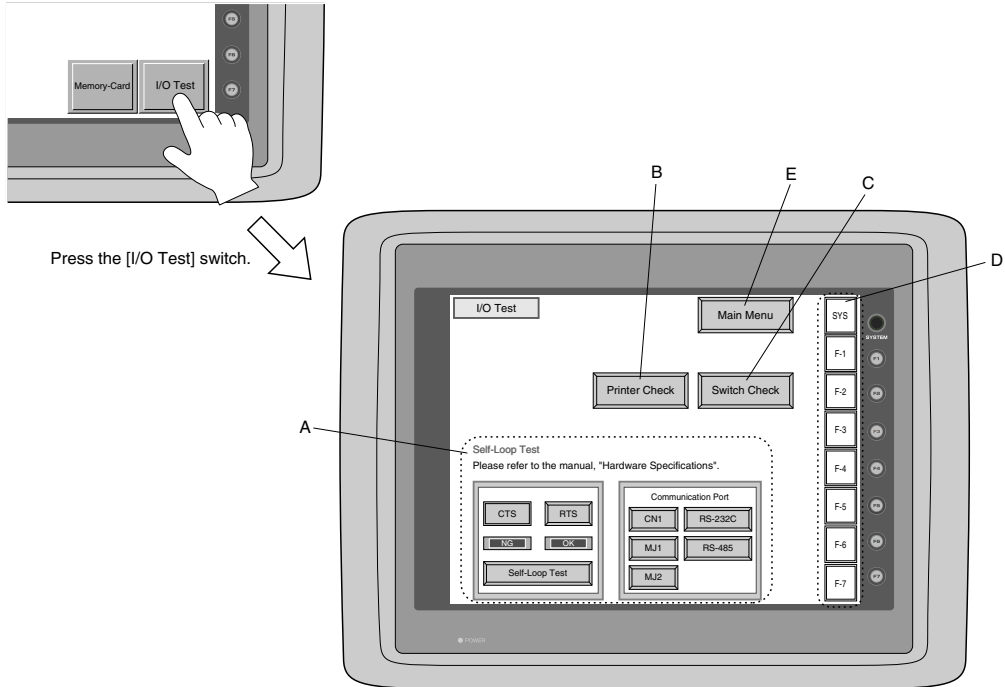

- * In case of V606/V606i, when the switch "A" on the "Main Menu" is pressed, the following "I/O Test" is displayed. Then, the "Serial Test" switch on the "I/O Test" is pressed. The following "Serial Test" is displayed. The self-loop test can be executed on this screen.

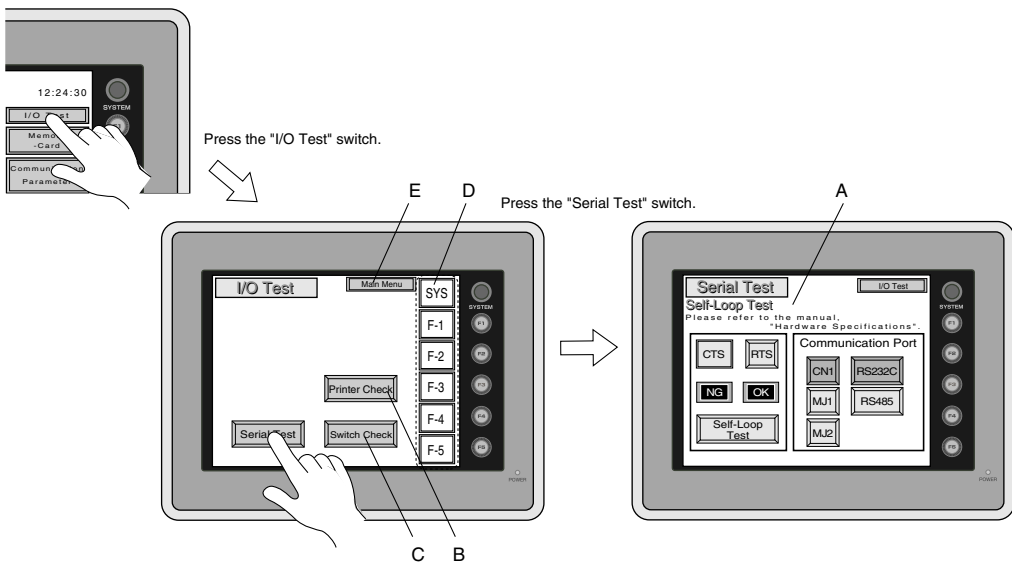

A. Self-loop Test

This is the test menu to check the signals necessary for V6 to communicate with PLC or a personal computer by using only V6.

○Signal Test of RS-232C in CN1

Select [CN1] and [RS-232C] in [Communication Port] by pressing each switch.

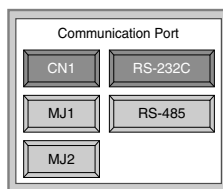

• Loop-back Test

Check the signals, [SD] and [RD].

1. Jump pins, 2 and 3 of CN1.

2. The test is OK, if the [OK] lamp turns on when the [Self-Loop Test] switch is pressed.

*** If the [NG] lamp turns on when the same switch as above is pressed, ask the advice of your distributor.**

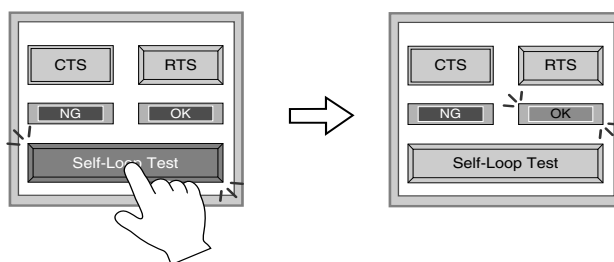

• Test of CTS/RTS

Check the signals, [CTS] and [RTS].

1. Jump pins, 4(RTS) and 5(CTS) of CN1.

2. The test is OK if the [CTS] lamp and the [RTS] lamp turn on at the same time that the [RTS] switch is pressed. Similarly, the test is OK if the [CTS] turns off at the same time that the [RTS] is turned off.

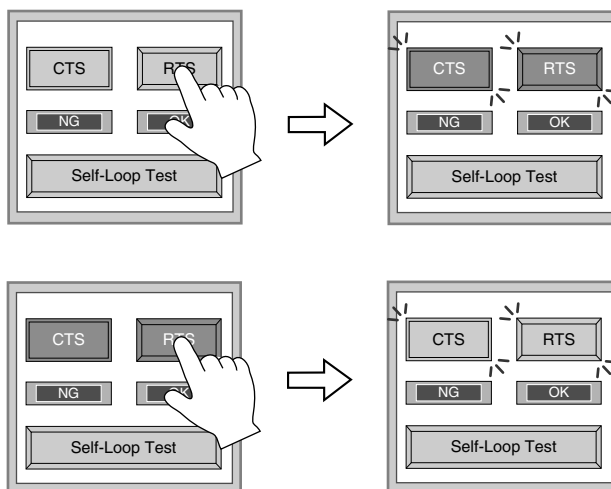

○Signal Test of RS-485 in CN1

Select [CN1] and [RS-485] in [Communication Port] by pressing each switch.

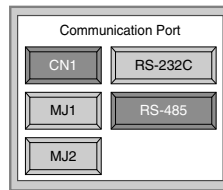

• Loop-back Test

Check the signals, [SD] and [RD].

1. Jump each pin, 12 and 24, 13 and 25 of CN1.
2. The test is OK, if the [OK] lamp turns on when the [Self-Loop Test] switch is pressed.

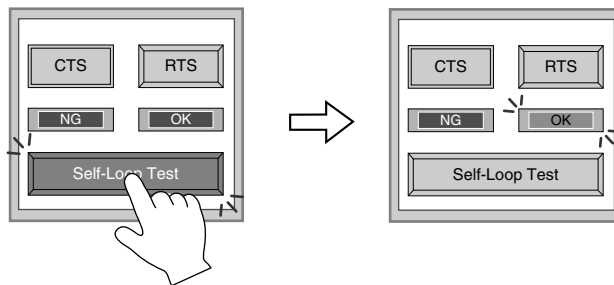

*** If the [NG] lamp turns on when the same switch as above is pressed, ask the advice of your distributor.**

• Test of CTS/RTS

Check the signals, [CTS] and [RTS].

1. Jump each pin, 14(+RTS) and 19(+CTS), 17(-RTS) and 18(-CTS) of CN1.
2. The test is OK if the [CTS] lamp and the [RTS] lamp turn on at the same time that the [RTS] switch is pressed. Similarly, the test is OK if the [CTS] turns off at the same time that the [RTS] is turned off.

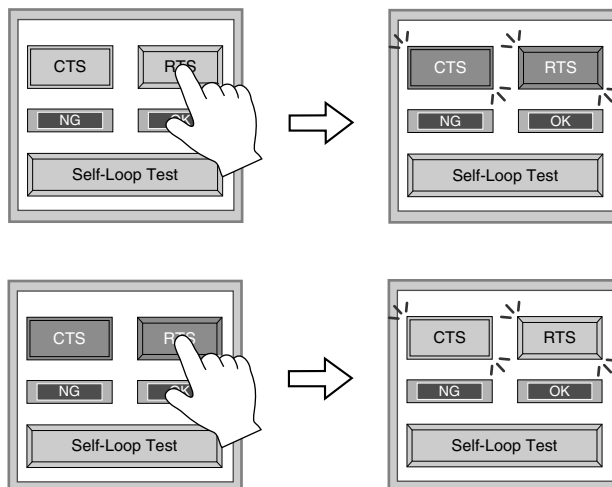

○Signal Test of RS-232C in MJ1 and MJ2

Select [MJ1] (or [MJ2]) and [RS-232C] in [Communication Port] by pressing each switch.

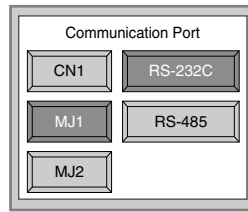

• Loop-back Test

Check the signals, [SD] and [RD].

Execute the test by connecting the data transfer cable (V6-CP) to CN1.

1. Set the adaptor, ADP25-9, which is attached to V6-CP, to V6-CP. And connect the modular jack side of V6-CP to MJ1 (or MJ2), ADP25-9 side of V6-CP to CN1.

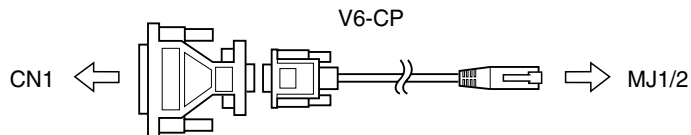

2. The test is OK, if the [OK] lamp turns on when the [Self-Loop Test] switch is pressed.

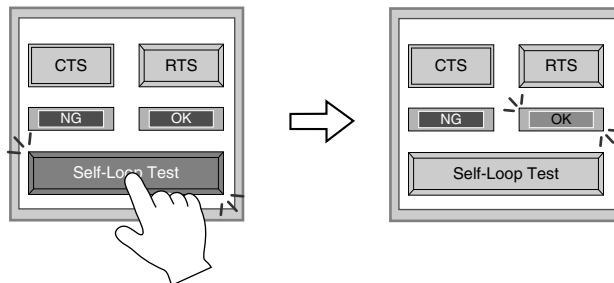

*** If the [NG] lamp turns on when the same switch as above is pressed, ask the advice of your distributor.**

○Signal Test of RS-485 in MJ1 and MJ2

When you execute the signal test of RS-485 in MJ1 and MJ2, ask the advice of your distributor.

B. Printer Check

Check the signal of printer.

The test is OK if the test printout is executed satisfactorily when connecting V6 to a printer and pressing this [Printer Check] switch.

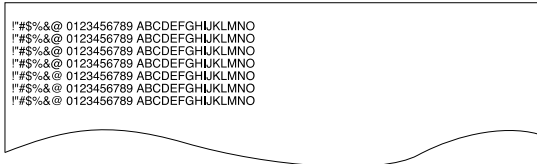

C. Switch Check

Check the reaction of the touch switches on the V6 panel.

When the [Switch Check] switch is pressed, the following screen is displayed.

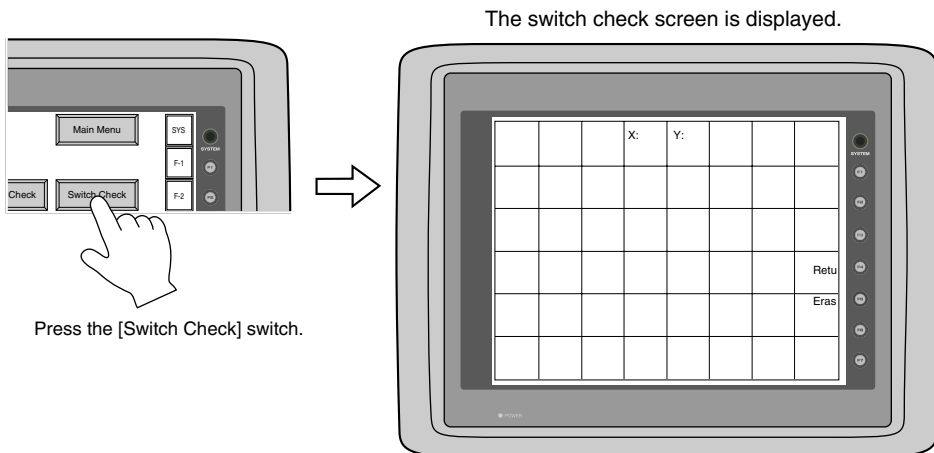

Confirm that the color of the pressed area changes into white.

The white color means that the switch reacts to the touch normally.

Pressing the [F4] switch leads to the previous [I/O Test] screen.

Pressing the [F5] switch deletes all the white dots.

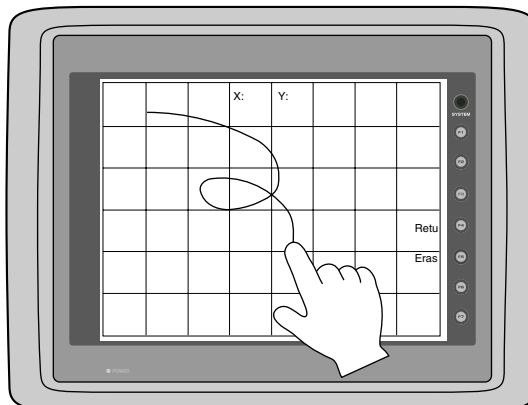

* In case of matrix type

When pressing the [Switch Check] switch, the following screen which is divided by a minimum size of switch is displayed. Confirm that the color of the pressed switch changes into white. Pressing the corner right below leads to the previous [I/O Test] screen.

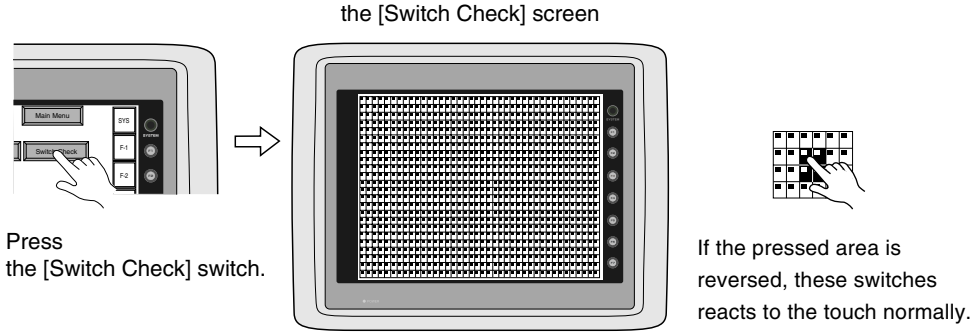

D. Test of SYSTEM & Function Switches

Check the eight switches (six switches for V606) placed vertically on the right side of the V6 panel. The test is OK if the lamps on the screen turn on when each switch is pressed.

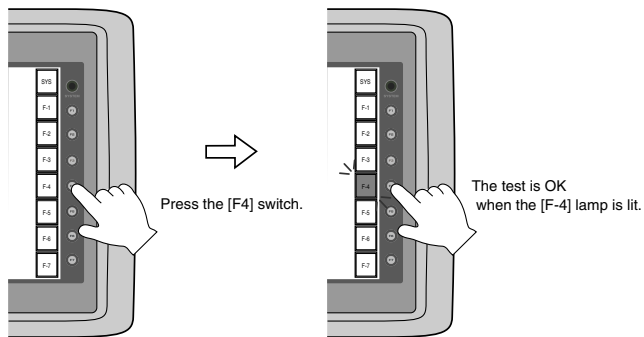

E. Main Menu

Pressing this [Main Menu] switch leads to the previous [Main Menu].

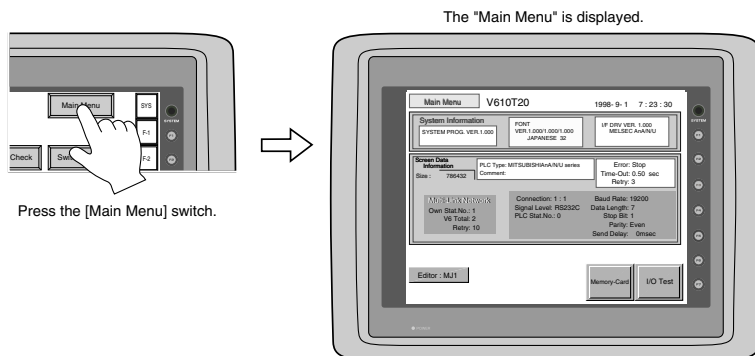

Memory-Card

When the [Memory-Card] switch on the "Main Menu" is pressed, the following "Memory-Card" is displayed. This screen is to transfer the screen data between V6 and a memory-card.

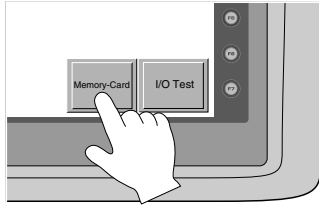

Press the [Memory-Card] switch.

The "Memory-Card" screen is displayed.

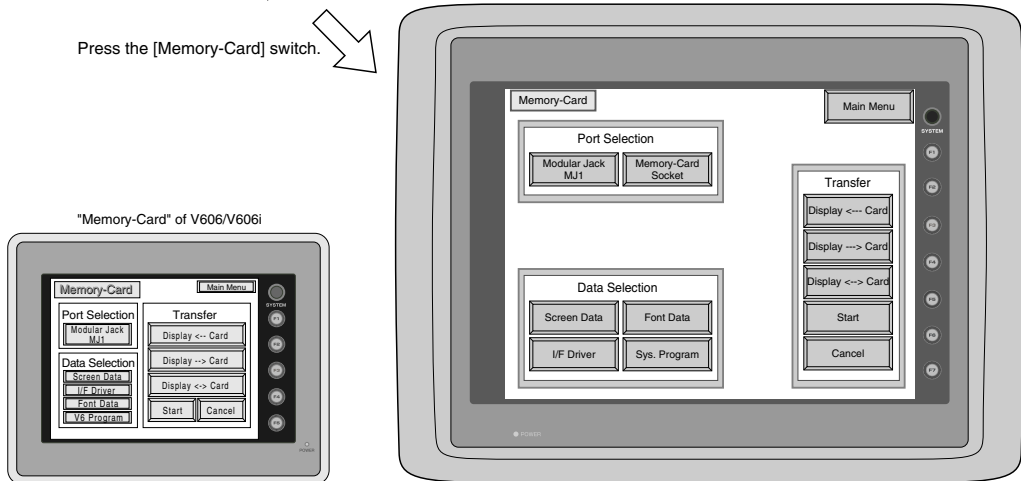

"Memory-Card" of V606/V606i

○ Procedure of Data Transferring

1) Port Selection

Select the [Modular Jack MJ1] switch (or [Modular Jack MJ2]) in case of using a modular jack. Select the [Memory-Card Socket] switch in case of using a memory-card interface. When each switch is pressed, the "Memory-Card Information" window is displayed.

In case of V606/V606i, pressing the "Close" switch leads to the original screen after checking the memory card information.

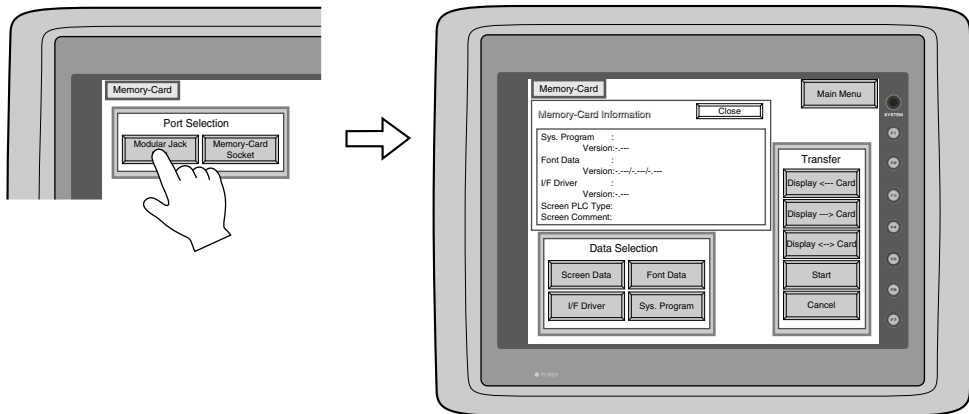

In case of selecting [Memory Card] from [Modular Jack 2] in the [Others] dialog of V-SFTE, it is possible to select the [Modular Jack 2] switch in the [Port Selection] menu of the [Memory-Card] screen on V6.

2) Data Selection, Transfer

Pressing each switch leads to selection of the target for data transferring. (Possible to select multiple items.)

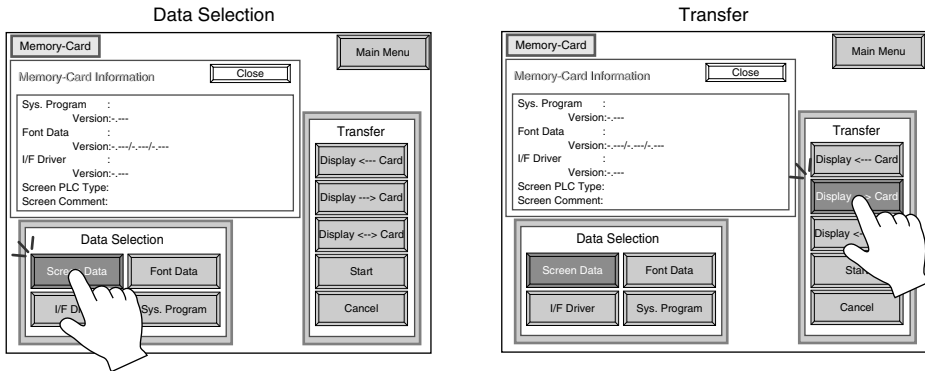

3) Start

When the [Start] switch is pressed, the data transferring starts. During data transfer, the character, 'Start', on the switch changes into the character, 'Busy', and the switch starts blinking. After transferring data, the following message is displayed. Press the [OK] switch.

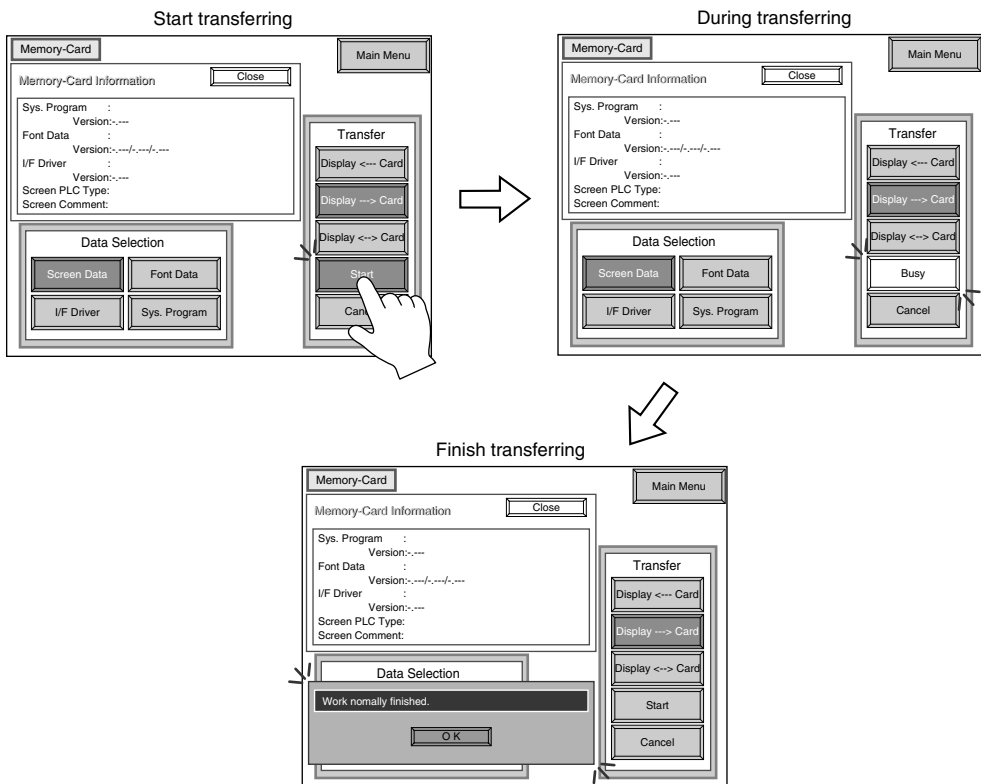

* When transfer the data from V6 to memorycard via the card interface(= [Memory-Card Socket]) of V6, use SRAM type memory card. FROM type memory card is not used.

○ Message Display in Data Transferring

If an error occurs during transferring data, the message display window shown on the right is displayed. The kinds and the contents of the messages are as shown below.

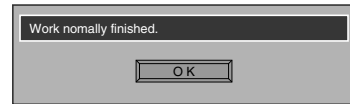

Message	Contents
Work normally finished.	The specified operation has been concluded normally.
CREC not connecting	CREC is not connecting when selecting a modular jack.
CREC Communication Error	A communication error occurred between V6 and CREC when selecting a modular jack.
Memory-Card not setting	A memory card is not inserted. (Or in case of trying to write data into a memory card when inserting FROM type memory card)
Memory-Card Capacity over	Cannot write the data into a memory card because the data size in V6 is larger than the capacity of a memory card.
Write Protect : ON	Cannot write data into a memory card because the write protect switch in a memory card is ON.
Writing Error occurred.	The error occurred while writing data into a memory card.
Selected data does not exist.	The data in the reading target does not exist.
V6 type is different.	The specified type of the data in V6 is different from the type of the memory card data.
Selected data can not be read.	The data in a memory card cannot be read.
Reading Error occurred.	The error occurred during writing data into a flash ROM of V6.
Data discrepant	There is some discrepancy in data, when comparing data between a memory card and V6.
Screen data on V6 will be broken.	This message appears to inform the user that the data in V6 will be broken by transferring the font data (the size which is larger than the present data) from a memory card to V6. (The [OK] switch continues the transferring. The [Cancel] switch stops transferring.)
Undefined Error occurred.	The error occurred due to some cause other than the above mentioned.

17 Function Switches

Type

[SYSTEM], [F1], [F2], [F3], [F4], [F5], [F6], [F7]
(V606/V606i : [SYSTEM], [F1]~[F5])

the [SYSTEM] switch

By pressing this switch, the functions of the switches [F1] ~ [F7] are defined.

The type of the [SYSTEM] switch is alternate. When this switch is pressed once, the switch menu is displayed by the side of the function switches [F1] ~ [F5], and each function switch corresponds to an item on the displayed switch menu.

When the [SYSTEM] switch is pressed again, the switch menu which is displayed on the screen will disappear, and the functions of switches [F1] ~ [F7] are defined for the purpose of the user. The data of these function switches is allocated to the memory area of PLC.

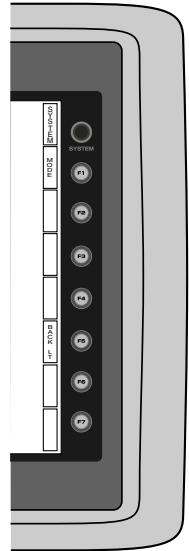

Function of [F1] ~ [F5] when the switch menu is displayed

○ [F1] : Mode

This switch changes the operation mode.

Main Menu Mode --> RUN Mode

Run Mode --> Main Menu Mode (possible to specify the changing time)

○ [F2] : Contrast Adjustment (dark) ----- invalid in case of the TFT color type

This switch adjusts the contrast of LCD. When the [F2] switch is pressed once, the LCD color becomes dark. If this switch is held down for 1 second, the LCD color changes rapidly into darkness.

○ [F3] : Contrast Adjustment (intermediate) ----- invalid in case of the TFT color type

This switch also adjusts the contrast of LCD. When the [F3] switch is pressed once, the LCD color becomes intermediate.

○ [F4] : Contrast Adjustment (light) ----- invalid in case of the TFT color type

This switch adjusts the contrast of LCD. When the [F4] switch is pressed once, the LCD color becomes light. If this switch is held down for 1 second, the LCD color changes rapidly into lightness.

○ [F5] : Backlight

This switch turns the backlight of V6 on or off.

If you want to use this function, you have to set [Backlight] of the [Others] dialog in [System Setting].

The following list shows the backlight function specified in the editing software.

Backlight	Function Switch (F5)
ON	Ignored.
Auto 1 Auto 2	The following actions are added to the regular functions of these items : Even if the time does not reach the setting time, the backlight will turn off if the [F5] switch is pressed (provided that bit 11(Backlight) of Read Area n+1 is OFF level). (Refer to the Reference Manual.)
Manual Manual2	If you select [Manual], the backlight will turn on or off only when this switch is pressed. Also, you can specify the item, [Backlight Power ON Time Control]. When you turn the power supply of V6 on ... [ON] : the backlight is lit. [OFF] : the backlight is off.

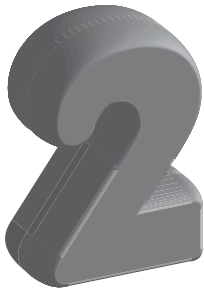

Connection to Link Units

1. MITSUBISHI PLC • 1
2. MITSUBISHI PLC • 2
3. MITSUBISHI PLC • 3
4. MITSUBISHI PLC • 4
5. MITSUBISHI PLC • 5
6. MITSUBISHI PLC • 6
7. OMRON PLC • 1
8. OMRON PLC • 2
9. Sharp PLC • 1
10. Sharp PLC • 2
11. HITACHI PLC • 1
12. HITACHI PLC • 2
13. Matsushita PLC
14. YOKOGAWA PLC • 1
15. YOKOGAWA PLC • 2
16. YASKAWA PLC • 1
17. YASKAWA PLC • 2
18. TOYOPUC PLC
19. FUJI PLC • 1
20. FUJI PLC • 2
21. FUJI PLC • 3
22. FUJI PLC • 4
23. Koyo PLC
24. Allen-Bradley PLC • 1
25. Allen-Bradley PLC • 2
26. GE Fanuc PLC • 1
27. GE Fanuc PLC • 2
28. TOSHIBA PLC
29. TOSHIBA MACHINE PLC
30. SIEMENS PLC • 1
31. SIEMENS PLC • 2
32. SIEMENS PLC • 3
33. SIEMENS PLC • 4
34. SIEMENS PLC • 5
35. SIEMENS PLC • 6
36. Shinko PLC
37. SAMSUNG PLC
38. KEYENCE PLC • 1
39. KEYENCE PLC • 2
40. KEYENCE PLC • 3
41. LG PLC
42. FANUC PLC
43. FATEK AUTOMATION PLC
44. IDEC PLC
45. MODICON PLC
46. YAMATAKE PLC
47. TAIAN PLC
48. SAIA PLC
49. MOELLER PLC
50. Telemecanique PLC
51. Automationdirect PLC
52. VIGOR PLC
53. DELTA PLC
54. BALDOR PLC

1

MITSUBISHI PLC • 1

(A/QnA/QnH (Q) series link)

Available PLC

Select PLC Type	PLC	Link Unit	Wiring Diagram (refer to P2-5, 6)	
A series link	A2A, A3A	AJ71C24-S6 AJ71C24-S8 AJ71UC24	RS-232C [Wiring Diagram 2]	
	A2U, A3U, A4U	AJ71UC24		
	A1, A2, A3 A1N, A2N, A3N A3H, A3M, A73	AJ71C24 AJ71C24-S3 AJ71C24-S6 AJ71C24-S8 AJ71UC24	RS-422 [Wiring Diagram 3]	
	A0J2, A0J2H	A0J2C214-S1		
	A2US		A1SJ71UC24-R2	RS-232C [Wiring Diagram 1]
			A1SJ71UC24-R4	RS-422 [Wiring Diagram 3]
			A1SJ71UC24-PRF	RS-232C [Wiring Diagram 1]
	A1S, A1SJ, A2S		A1SJ71C24-R2	RS-232C [Wiring Diagram 1]
			A1SJ71C24-R4	RS-422 [Wiring Diagram 3]
			A1SJ71C24-PRF	RS-232C [Wiring Diagram 1]
A2CCPUC24	CPU built-in port	RS-232C [Wiring Diagram 1]		
QnH(A mode)		A1SJ71UC24-R2	RS-232C [Wiring Diagram 1]	
		A1SJ71UC24-R4	RS-422 [Wiring Diagram 3]	
QnA series link	Q2A, Q3A, Q4A Q2ASx	AJ71QC24N	RS-232C [Wiring Diagram 2] RS-422 [Wiring Diagram 3]	
		AJ71QC24	RS-232C [Wiring Diagram 2] RS-422 [Wiring Diagram 3]	
		A1SJ71QC24	RS-232C [Wiring Diagram 1] RS-422 [Wiring Diagram 3]	
		AJ71QC24-R4(CH1)	RS-422 [Wiring Diagram 4]	
		AJ71QC24-R4(CH2)	RS-422 [Wiring Diagram 3]	
QnH(Q) series link	QnH(Q mode)	QJ71C24	RS-232C [Wiring Diagram 1]	
	Q00, Q01, Q00J		RS-422 [Wiring Diagram 3]	
	Q00, Q01	Tool port *1	RS-232C Hakko Electronics' cable "QCPU2"	

*1 When connecting V6 series to the tool port of Q00 or Q01 CPU, refer to page 2-2.
About the ladder transfer function, refer to Appendix.

Communication Setting

The recommended communication parameter setting of both PLC and V6 is as follows:

◆A series link

Item	Setting of PLC	Comm. Parameter of V6	
Baud Rate	19200bps	19200bps	
Port	0 for both STATION X 10 and X1	0	
Parity	Even	Even	
Transmission Control Mode ^{*1}	RS-232C	MODE1	Trans. Mode 1
	RS-422	MODE5	Trans. Mode 1
Transmission Code	Data Length	7 (ASCII)	7
	Stop Bit	1	1
Sumcheck	Provided (fixed)	_____	
Write while running	Available (fixed)	_____	
Terminal Resistor at Sender	Provided (fixed)	_____	
Terminal Resistor at Receiver	Provided (fixed)	_____	

*1 Mode 1: without CR/LF, Mode 4: with CR/LF

If [Trans. Mode 4] is selected from [Trans. Mode] in [Comm. Parameter] of the panel editor, specify [MODE4] in case of RS-232C, or select [MODE8] in case of RS-422.

◆QnA series link, QnH(Q) series link

Item	Setting of PLC	Comm. Parameter of V6	
Baud Rate	19200bps	19200bps	
Port	0 for both STATION X 10 and X1	0	
Parity	Even	Even	
Transmission Control Mode	RS-232C	When QnA series link is connected: MODE5 (Binary Mode) (fixed). When QnH(Q) series link is connected: MC Protocol Type 5 (fixed).	_____
	RS-422		
Transmission Code	Data Length	8 (fixed)	_____
	Stop Bit	1	1
Sumcheck	Provided (fixed)	_____	
Write while running	Available (fixed)	_____	

◆Q00/Q01 CPU

When connecting the V6 series to the tool port of Q00 or Q01 CPU, it is necessary to specify [serial communication] setting on PLC parameter. Note on the following setting.

V-SFT

Select [QnH(Q) series link] in [PLC type].

GX Developer (Application software for programming MITSUBISHI PLCs)

1. Double click [PLC parameter].
2. Click the [Serial] tab menu of the [Qn(H) Parameter] dialog.
3. Check [Use serial communication] to specify communication parameters such as Baud rate, Sum check, etc.

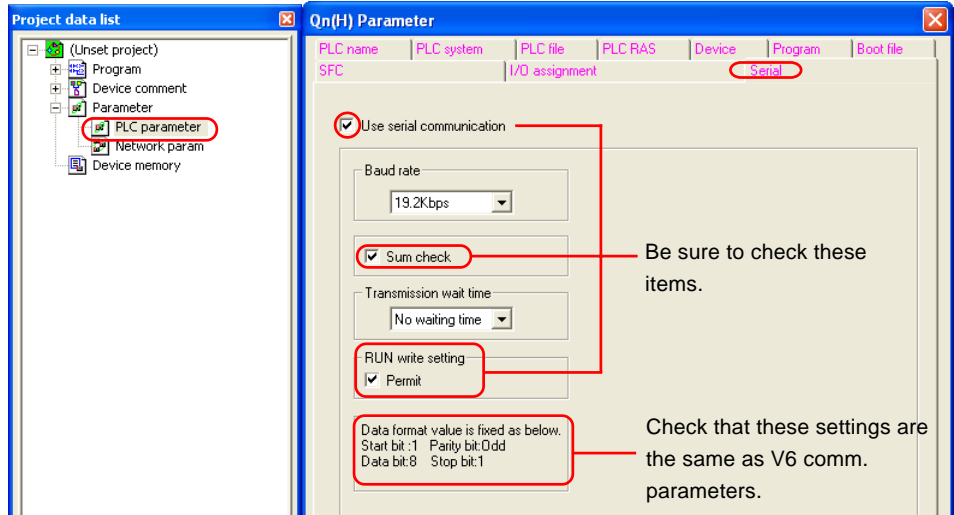

Switch Setting

The following is an example to show the settings for both rotary dip switches and dip switches on PLC.

<E.g. 1> Signal Level: RS-232C, Baud Rate: 19200bps, Trans. Mode: Trans. Mode 1

AJ71UC24

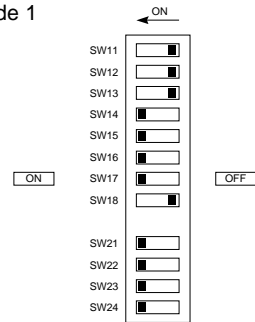
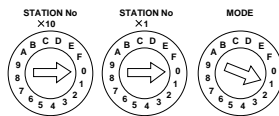

<E.g. 2> Signal Level: RS-232C, Baud Rate: 19200bps, Trans. Mode: Trans. Mode 1

A1SJ71C24-R2

A1SJ71UC24-R2

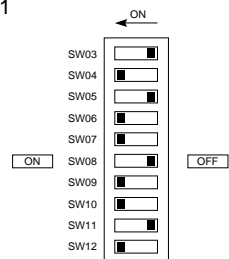
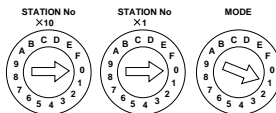

<E.g. 3> Baud Rate: 19200bps

AJ71QC24

A1SJ71QC24

AJ71QC24N

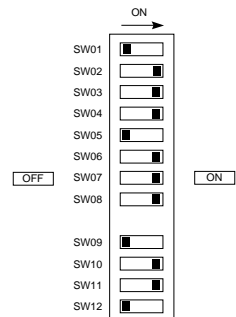
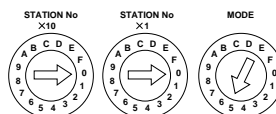

<E.g. 4> Signal Level: RS-422, Baud Rate: 19200bps, Trans. Mode: Trans. Mode 1

A1SJ71UC24-R4

A1SJ71C24-R4

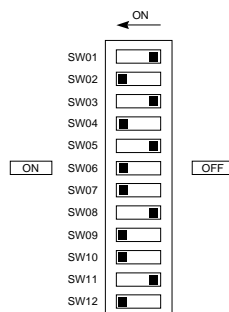
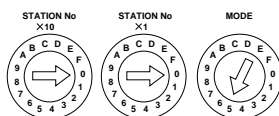

Available Memory

Memory	TYPE	Remarks
D (data register)	0	
W (link register)	1	
R (file register)	2	
TN (timer/current value)	3	
CN (counter/current value)	4	
SPU (special unit)	5	Unit No. *1
M (internal relay)	6	
L (latch relay)	7	
B (link relay)	8	
X (input relay)	9	
Y (output relay)	10	
TS (timer/contact)	11	
TC (timer/coil)	12	
CS (counter/contact)	13	
CC (counter/coil)	14	
H (link buffer)	15	
SD (special register)	16	QnA, QnH(Q) series only
SM (special relay)	17	QnA, QnH(Q) series only
SB (special link relay)	18	QnA, QnH(Q) series only
SW (special link register)	19	QnA, QnH(Q) series only
ZR (file register [continuous access])	20	QnA, QnH(Q) series only

*1 The unit number is required in addition to the memory type and the address.

Convert a byte address into a word address to enter the data if the memory device of link unit is byte address.

Set the memory to the extent of the memory range of each PLC model.

Use TYPE number to assign indirect memory for macro programs.

Wiring

The following is a diagram to show the wiring of the cable which connects V6 to PLC.

RS-232C

Wiring Diagram 1

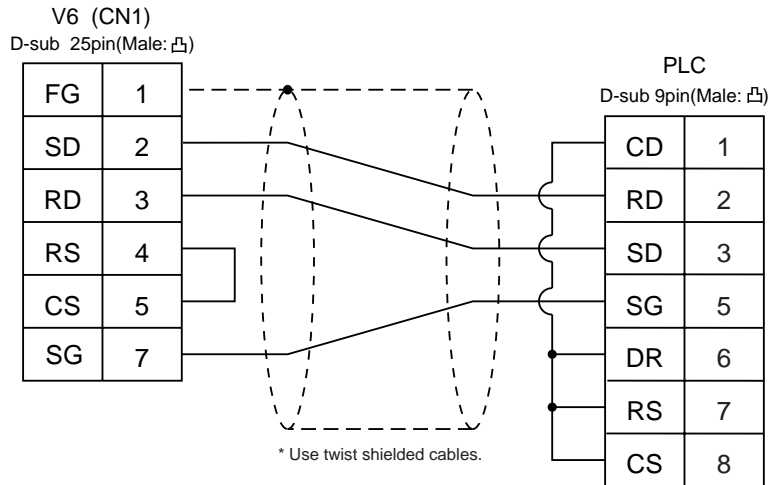

Wiring Diagram 2

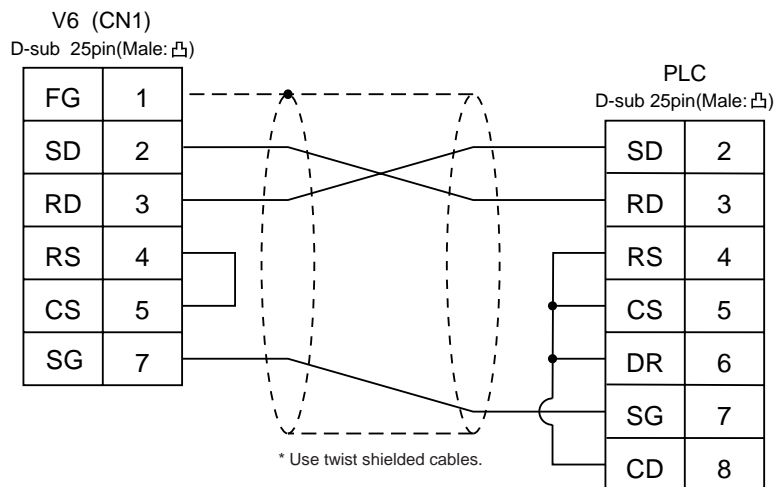

RS-422

Wiring Diagram 3

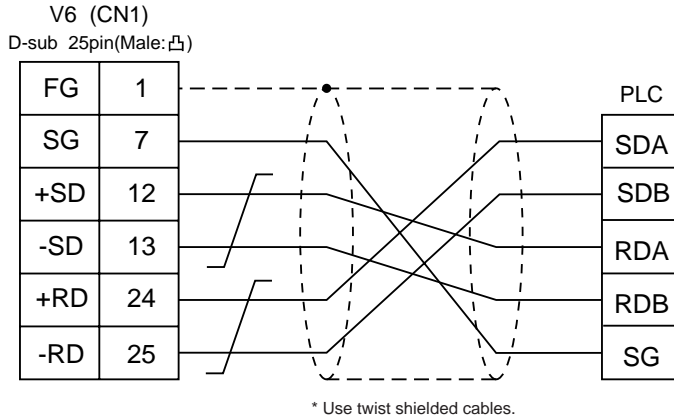

Wiring Diagram 4

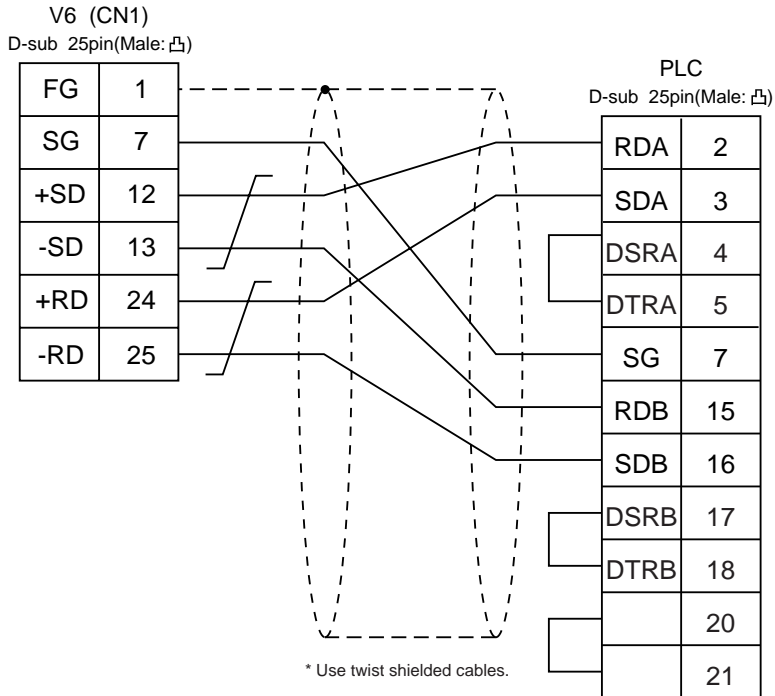

2 MITSUBISHI PLC • 2

(A/QnA series CPU)

Connection

Connect to the A/Q series CPU port.

The communication parameter setting of V6 is done automatically.

Available PLC

Select PLC Type	PLC	Wiring Diagram (refer to P2-9)
A series CPU	A2A, A3A A2U, A3U, A4U A2US(H) A1N, A2N, A3N A3V, A73 A3H, A3M A0J2H A1S, A1SJ(H), A2S(H) A2CCPUC24 A1FX	RS-422 [MB-CPUQ] made by Hakko Electronics or [Wiring Diagram 1]
QnA series CPU	Q2A, Q3A, Q4A Q2AS(H)	

When the CPU is updated, or the specifications are changed, there is some possibility that V6 cannot be connected to the PLC.

Available Memory

Memory	TYPE	Remarks
D (data register)	0	
W (link register)	1	
R (file register)	2	
TN (timer/current value)	3	*2
CN (counter/current value)	4	
SPU (special unit)	5	Unit No. *1
M (internal relay)	6	
L (latch relay)	7	
B (link relay)	8	
X (input relay)	9	
Y (output relay)	10	
TS (timer/contact)	11	
TC (timer/coil)	12	
CS (counter/contact)	13	
CC (counter/coil)	14	
SD (special register)	16	only in QnA
SM (special relay)	17	only in QnA
SB (special link relay)	18	only in QnA
SW (special link register)	19	only in QnA
ZR (file register [continuous access])	20	only in QnA

*1 The unit number is required in addition to the memory type and the address.

Convert a byte address into a word address to enter the data if the memory device of link unit is byte address.

*2 File register(R) cannot be used in case of ROM operation of A series CPU.

Set the memory to the extent of the memory range of each PLC model.

Use TYPE number to assign indirect memory for macro programs.

Wiring

The following is a diagram to show the wiring of the cable which connects V6 to PLC.

RS-422

Use the cable, [MB-CPUQ](2, 3, 5, 10, 15m) made by Hakko Electronics Co., Ltd.

Wiring Diagram 1 < MB-CPUQ >

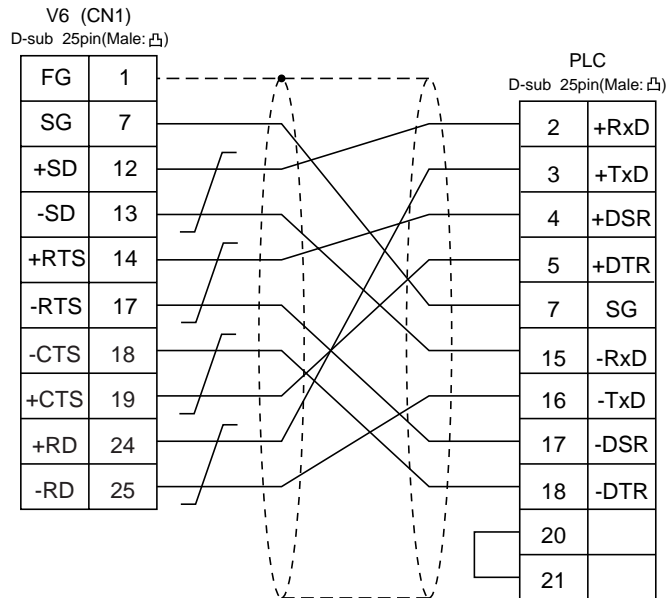

* Use twist shielded cables.

Note

According to our noise tests, the attachment of a ferrite core improves noise voltage by 650~900V and aids in preventing communication errors.

- In case of direct connection with the CPU port of A/QnA series, be sure to attach the ferrite core to the cable between V6 and the CPU port of A/QnA series for noise.

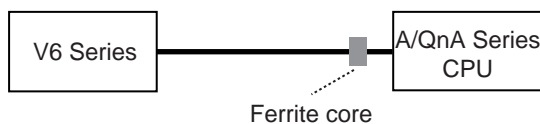

- A Ferrite core is sold as an optional accessory.
When you buy it, specify "GD-FC (internal diameter : 8mm, external diameter : 20mm)" as the model name.
- In consideration of such noise problems, it is recommended that the standard type link unit be used in such a case when the cable length of more than 15m is required.

Notes on using V-MDD (Dual Port Interface)

- As the V-MDD is powered by a CPU, check that the electric capacity of the CPU is at 5V (power consumption: max. 350mA).
- The distance between the CPU and the V-MDD should be as short as possible (max. 1~1.5m).
- For wiring, take appropriate measures to eliminate noise.
- Specify the value more than 150 (=1.5 sec) in [Time-out Time] of [Comm. Parameter] in case of connecting V6 to a V-MDD.

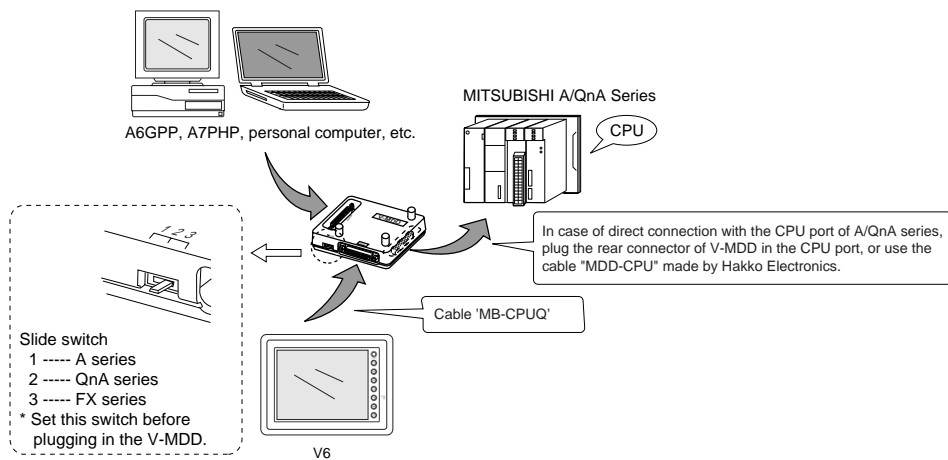

3 MITSUBISHI PLC • 3

(QnH series CPU)

Connection

Connect to the QnH series CPU port.

The communication parameter setting of V6 is done automatically.

Available PLC

Select PLC Type	CPU	Wiring Diagram (refer to P2-12)
QnH(A) series CPU	Q06H-A	RS-232C cable [QCPU2] made by Hakko Electronics
*1 QnH(Q) series CPU	Q02 Q02H Q06H Q12H Q25H	

*1 About the ladder transfer function, refer to Appendix.

When the CPU is updated, or the specifications are changed, there is some possibility that V6 cannot be connected to the PLC.

Available Memory

Memory	TYPE	Remarks
D (data register)	0	
W (link register)	1	
R (file register)	2	
TN (timer/current value)	3	
CN (counter/current value)	4	
SPU (special unit)	5	Unit No. *1
M (internal relay)	6	
L (latch relay)	7	
B (link relay)	8	
X (input relay)	9	
Y (output relay)	10	
TS (timer/contact)	11	
TC (timer/coil)	12	
CS (counter/contact)	13	
CC (counter/coil)	14	
SD (special register)	16	only in Q mode
SM (special relay)	17	only in Q mode
SB (special link relay)	18	only in Q mode
SW (special link register)	19	only in Q mode
ZR (file register [continuous access])	20	only in Q mode

*1 The unit number is required in addition to the memory type and the address.

Convert a byte address into a word address to enter the data if the memory device of link unit is byte address.

Set the memory to the extent of the memory range of each PLC model.

Use TYPE number to assign indirect memory for macro programs.

Wiring

RS-232C

Use the cable, [QCPU2](2, 3, 5, 10, 15m), made by Hakko Electronics Co., Ltd.

4 MITSUBISHI PLC • 4

(FX/FX2N/FX1S series CPU)

Connection

Connect to the FX series CPU port.

The communication parameter setting of V6 is done automatically.

Available PLC

Select PLC Type	CPU	Wiring Diagram(refer to P2-15)
FX series CPU	FX1/2	RS-232C [PC-CX24A] made by Hakko Electronics RS-422 [MB-CPUQ] made by Hakko Electronics or [Wiring Diagram 1]
	FX0N (tool port)	RS-422 [M4-FX] made by Hakko Electronics or [MB-CPUQ] made by Hakko Electronics + [FX-20P-CADP] made by MITSUBISHI
FX2N series CPU	FX2N/1N (tool port) FX2NC (tool port)	
FX1S series CPU	FX1S (tool port)	

About the ladder transfer function, refer to Appendix.

When the CPU is updated, or the specifications are changed, there is some possibility that V6 cannot be connected to the PLC.

Available Memory

- FX1/2, FX0N, FX1S series CPU

Memory	TYPE	Remarks
D (data register)	0	
TN (timer/current value)	1	
CN (counter/current value)	2	
32CN (counter 32bits)	3	* 1
M (internal relay)	4	
S (state)	5	
X (input relay)	6	Read only
Y (output relay)	7	
TS (timer/contact)	8	
CS (counter/contact)	9	
DX (Data register)	10	*2

*1 In case of the items which can display double word data (e.g. data display, graph, sampling), the data is managed as double word data.

Both bit data and word data are managed as lower-half 16 bits data.

Input : 16 upper-half bits are ignored.

Output : "0" is written in the 16 upper-half bits.

*2 When use D1000 ~ 2999, select DX.

- FX2N, FX1N series CPU

Memory	TYPE	Remarks
D (data register)	0	
TN (timer/current value)	1	
CN (counter/current value)	2	
32CN (counter 32bits)	3	
M (internal relay)	4	* 1
S (state)	5	
X (input relay)	6	Read only
Y (output relay)	7	
TS (timer/contact)	8	
CS (counter/contact)	9	

*1 In case of the items which can display double word data (e.g. data display, graph, sampling), the data is managed as double word data.

Both bit data and a word data are managed as lower-half 16 bits data.

Input : 16 upper-half bits are ignored.

Output : "0" is written in the 16 upper-half bits.

Set the memory to the extent of the memory range of each PLC model.

Use TYPE number to assign indirect memory for macro programs.

Wiring

The following is a diagram to show the wiring of the cable which connects V6 to PLC.

RS-232C

Use the cable, "PC-CX24A"(3m), made by Hakko Electronics Co., Ltd. in case of RS-232C connection.

RS-422

Use the cable, "MB-CPUQ"(2, 3, 4, 5, 10, 15m) or "MI4-FX"(2, 3, 4, 5, 10, 15m) made by Hakko Electronics Co., Ltd.

Wiring Diagram 1 < MB-CPUQ >

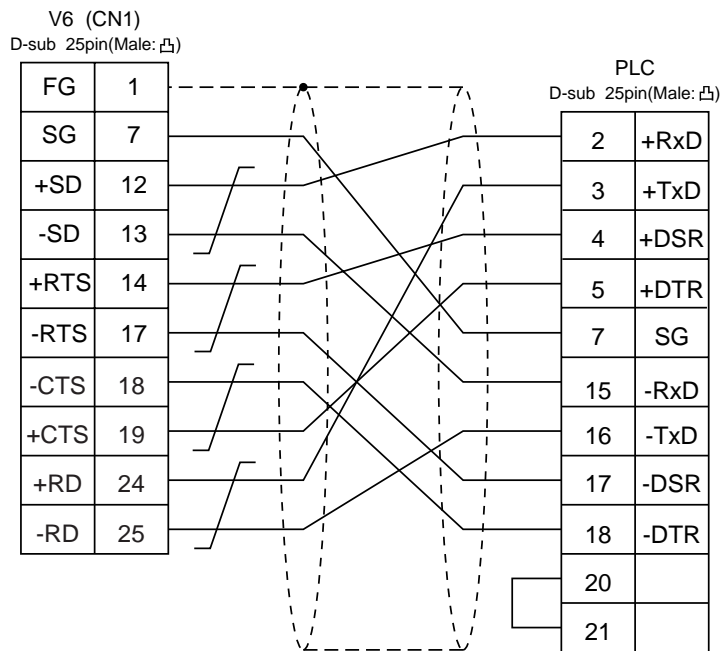

* Use twist shielded cables.

Note

According to our noise tests, the attachment of a ferrite core improves noise voltage by 650~900V and aids in preventing communication errors.

- In case of direct connection with the CPU port of FX series, be sure to attach the ferrite core to the cable between V6 and the CPU port of FX series for noise.



- A Ferrite core is sold as an optional accessory.
When you buy it, specify "GD-FC (internal diameter : 8mm, external diameter : 20mm)" as the model name.

Notes on using V-MDD (Dual Port Interface)

- As the V-MDD is powered by a CPU, check that the electric capacity of the CPU is at 5V (power consumption: max. 350mA).
- The distance between the CPU and the V-MDD should be as short as possible (max. 1~1.5m).
- For wiring, take appropriate measures to eliminate noise.
- Specify the value more than 150 (=1.5 sec) in [Time-out Time] of [Comm. Parameter] in case of connecting V6 to a V-MDD.

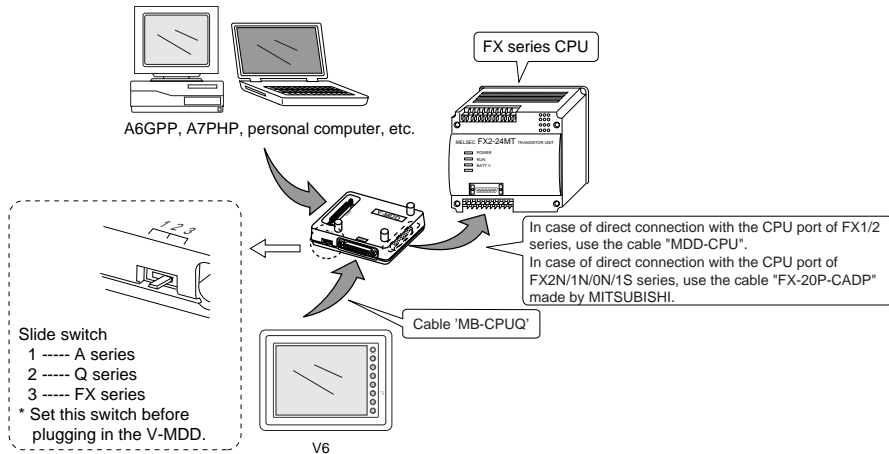

* When use the cable "M4-FX", it is impossible to use the V-MDD.

5 MITSUBISHI PLC • 5

(FX series link [A prt])

Available PLC

Select PLC Type	PLC	Link Unit	Wiring Diagram (refer to P2-19)
FX series (A protocol)	FX2N	FX2N-232-BD	RS-232C [Wiring Diagram 1]
		FX2N-485-BD	RS-485 [Wiring Diagram 3]
		FX2N-422-BD	RS-422 [MI4-FX] made by Hakko Electronics
	FX1N FX1S	FX1N-232BD	RS-232C [Wiring Diagram 1]
		FX1N-485-BD	RS-485 [Wiring Diagram 3]
		FX1N-422-BD	RS-422 [MI4-FX] made by Hakko Electronics
	FX0N	FX0N-232ADP	RS-232C [Wiring Diagram 2]
		FX0N-485ADP	RS-485 [Wiring Diagram 3]
	FX2NC	FX0N-232ADP	RS-232C [Wiring Diagram 2]
		FX0N-485ADP	RS-485 [Wiring Diagram 3]

Communication Setting

The recommended communication parameter setting of both PLC and V6 is as follows:

Item		Setting of PLC	Comm. Parameter of V6
Baud Rate		19200bps	19200bps
Parity		Even	Even
Transmission Code	Data Length	7	7
	Stop Bit	1	1
Protocol		Exclusive Protocol Communication (fixed)	—————
H/W Type *1		Normally RS-232C	RS-232C
Sumcheck		Provided (fixed)	—————
Transmission Control Mode		MODE 1	Trans. Mode 1

*1 When the link unit, FX2N-485-BD, FX2N-422-BD, FX1N-485-BD, FX1N-422-BD, FX0N-485-ADP is used, select [RS-485] in [Signal Level].

At the [Detail Setting] menu of the [Comm. Parameter] dialog of V-SFTE, setting the value more than [2] in [Send Delay Time] is recommended.

Available Memory

Memory	TYPE	Remarks
D (data register)	0	
TN (timer/current value)	1	
CN (counter/current value)	2	
32CN (counter 32bits)	3	* 1
M (internal relay)	4	* 2
S (state)	5	
X (input relay)	6	Read only
Y (output relay)	7	
TS (timer/contact)	8	
CS (counter/contact)	9	

*1 The meaning of CN200~CN255 is the same as the meaning of 32CN(counter 32bits).

*2 In case of the items which can display double word data (e.g. data display, graph, sampling), the data is managed as double word data.

Both bit data and a word data are managed as lower-half 16 bits data.

Input : 16 upper-half bits are ignored.

Output : "0" is written in the 16 upper-half bits.

Set the memory to the extent of the memory range of each PLC model.

Use TYPE number to assign indirect memory for macro programs.

Wiring

The following is a diagram to show the wiring of the cable which connects V6 to PLC.

RS-232C

Wiring Diagram 1

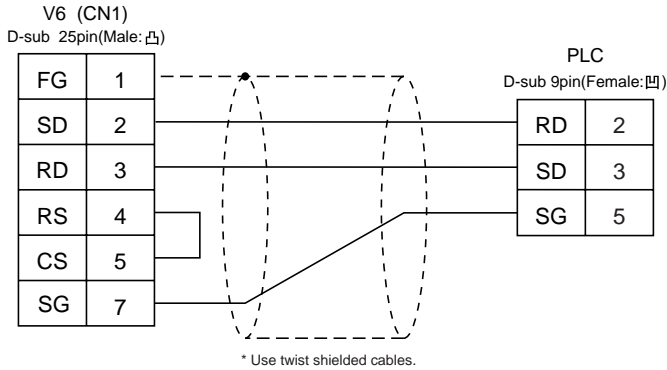

Wiring Diagram 2

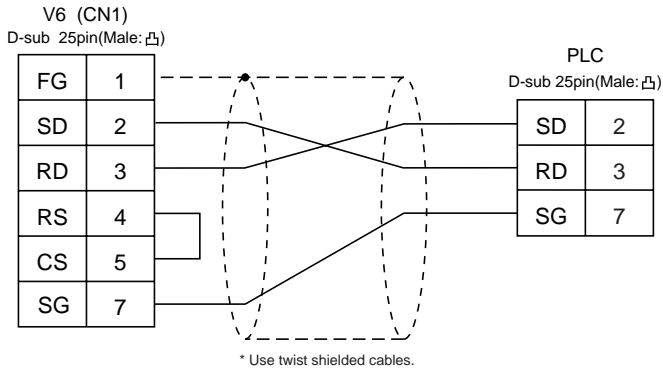

RS-422

Use the cable, "MI4-FX"(2,3,5,10,15m), made by Hakko Electronics Co., Ltd.

RS-485

Wiring Diagram 3

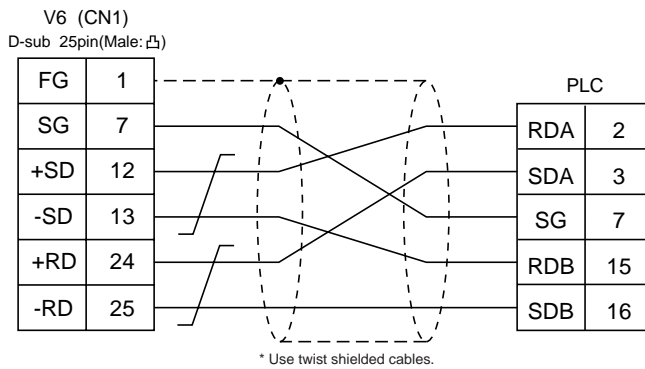

6 MITSUBISHI PLC • 6

(A link+Net10)

Change of PLC Type

PLC Type "Net 10," changes to "A link+Net10," and the new "Net10" adds to PLC Type in V-SFTE Ver.1.2.16.0 or later.

To select "Net10" as a new type, refer to "Specifications for Communication Unit [NET/10]."

- V6 can access other CPUs on the NET II(/B) or NET/10 when V6 is connected to one of the link units that the data link system or network system consists of.
Select "Net10" as PLC setting when configuring the screen data on the V-SFTE.
- To access other CPU on the NET II (/B) or NET/10 from V6.
 - In case of NET II(/B), only the network which has the CPU with the link unit connected to the V6 (e.g. No. 1) can be accessed.
(Available CPU No.: 0~30)
 - In case of NET/10, other networks (No. 2, No. 3) can be accessed in addition to the network No. 1.
(Available CPU No.: 1~30)
- To read/write the memories of the CPU(e.g. 1-1 of CPU) which has the link unit to be connected to the V6:

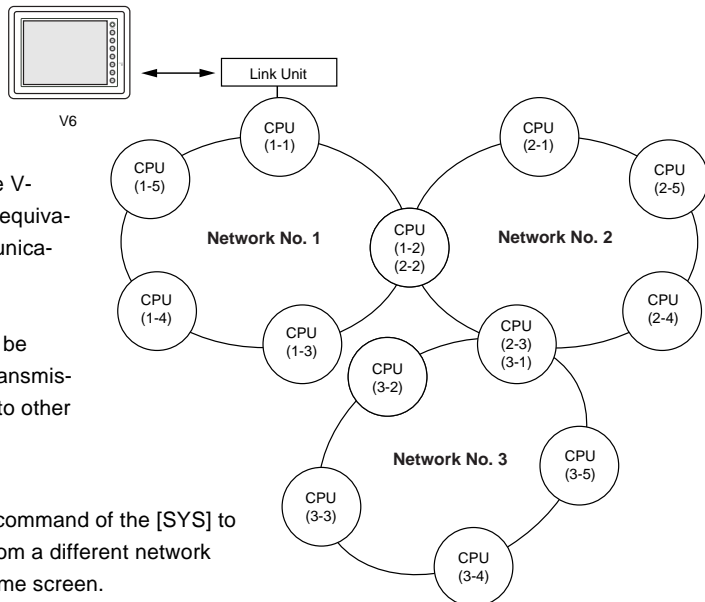

Set the CPU No. to "31" on the V-SFTE. Response time will be equivalent to the case of 1 : 1 communication.

Please note that response will be delayed due to the transient transmission when the CPU No. is set to other than "31".

- In this case, use [OUT_ENQ] command of the [SYS] to program the macro. A CPU from a different network cannot be accessed on the same screen.
When accessing PLCs of other network numbers on NET/10, specify the network number to be connected with the screens Open Macro in V-SFTE.

- Macro type to specify network [OUT_ENQ] command of [SYS]

F1 Memory

n+0	0 (fixed)
n+1	Specify network: 2 (fixed)
n+2	System code
n+3	Network No.

The addresses n+0 and n+1 are fixed for 0 and 2.

Specify n+2 [System code] to 1: NET/10 2: NET II(/B)

Enter "0" to n+3 [Network No.] when n+2 [System code] indicates "2", and "the number to be accessed" to n+3 [Network No.] when n+2 [System code] indicates "1".

No macros can include this command except Open Macro. Communication error will occur due to the execution of the network change when this command is used in other kinds of macros.

Refer to the "V series Reference Manual" for further information on Macro.

Also refer to MITSUBISHI's manual for network registration.

- See MITSUBISHI's manual for details on the NET II(/B) data link system and the NET/10 network system.

Available Memory

See P2-1, "A/Q series link units" and P2-7, "A/QnA series CPU port" for available memory of the PLC to be accessed.

Note that CPU No. should be set on V-SFTE.

Wiring

See the wiring diagrams on P2-5,6, "1 MITSUBISHI PLC • 1."

7 OMRON PLC • 1

Available PLC

Select PLC Type	PLC	Link Unit	Wiring Diagram (refer to P2-25, 26)
SYSMAC C	C20H, C28H, C40H	CPU unit with a built-in RS-232C port (host link port)	RS-232C [Wiring Diagram 1]
	C120, C120F C200H C500, C500F C1000H C2000, C2000H	C120-LK201-V1 C120-LK202-V1	RS-232C [Wiring Diagram 3] RS-422 [Wiring Diagram 4]
	C200H C200HS-CPU01,03 C200HS-CPU21,23 C200HS-CPU31,33	C200H-LK201 C200H-LK201-V1 C200H-LK202 C200H-LK202-V1	RS-232C [Wiring Diagram 3] RS-422 [Wiring Diagram 4]
	C200HS-CPU21,23 C200HS-CPU31,33 CQM1-CPU21 CQM1-CPU41, 42, 43, 44	CPU unit with a built-in RS-232C port (host link port)	RS-232C [Wiring Diagram 2]
	C500, C500F C1000H C2000, C2000H	C500-LK203	RS-232C [Wiring Diagram 3] RS-422 [Wiring Diagram 4]
	C200HX C200HG C200HE	CPU unit with a built-in RS-232C port (host link port)	RS-232C [Wiring Diagram 2]
		Communication board (C200HW-COM2-06)	RS-232C [Wiring Diagram 2] RS-422 [Wiring Diagram 5] *1
	SRM1-C02	RS-232C interface	RS-232C [Wiring Diagram 2]
	CPM1A	CPU unit (peripheral port)	[CQM1-CIF01] *2 made by OMRON
SYSMAC CV	CV500, CV1000 CV2000 CVM1	CPU unit with a built-in RS-232C port (host link port)	RS-232C [Wiring Diagram 2] RS-422 [Wiring Diagram 6]
		CV500-LK201	RS-232C PORT1 [Wiring Diagram 3] PORT2 [Wiring Diagram 2] RS-422 PORT2 [Wiring Diagram 5]
SYSMAC CS1	CS1	CPU unit with a built-in RS-232C port (host link port)	RS-232C [Wiring Diagram 2]
		CS1W-SCU21	RS-232C [Wiring Diagram 2]
		Communication board (CS1W-SCB41)	RS-232C [Wiring Diagram 2] RS-422 [Wiring Diagram 7] *1
	CJ1, CJ1M	CPU unit with a built-in RS-232C port (host link port)	RS-232C [Wiring Diagram 2]

*1 Cannot be connected to V6 by multi-link connection.

*2 Exchange the shell, the side of D-sub25. (recommendation : 17J-25 made by DDK)

Communication Setting

The recommended communication parameter setting of both PLC and V6 is as follows:

Item		Setting of PLC	Comm. Parameter of V6
Baud Rate		19200bps	19200bps
Port		0	0
Parity		Even	Even
Transmission Code	Data Length	7 (ASCII)	7
	Stop Bit	2	2
Command Level		3 (fixed)	_____
1 : 1/1 : n Protocol		1 : n (fixed)	_____
Synchronizing Switch		Internal Synchronization (fixed)	_____
CTS Switch		0V (normally ON) (fixed)	_____
5V Supply Switch		OFF (fixed)	_____
Terminal Resistor		ON for RS-422	_____

- Set the [Trans. Mode] for [Detail] in the [Comm. Parameter] in V-SFTE.

Trans. Mode	Contents
Trans. Mode 1	w/o sign BCD
Trans. Mode 2	w/+/- sign BCD *1

*1 w/+/- sign BCD

It is possible to display the data for PLC data with signs + and -.

When higher 4 bits of the memory are [F or A], treat the data as the minus data.

[F] : regards higher 4 bits of the memory as [-0]

[A] : regards higher 4 bits of the memory as [-1]

- range 1 word : -1999 ~ +9999
- 2 words : -19999999 ~ +99999999

<Ex.>

PLC memory	Display of V6
0000 ~ 9999	0 ~ 9999
F001 ~ F999	-1 ~ -999
A000 ~ A999	-1000 ~ -1999
00000000 ~ 99999999	0 ~ 99999999
F0000001 ~ F9999999	-1 ~ -9999999
A0000000 ~ A9999999	-10000000 ~ -19999999

- How to set : Num. Display
 [Input Type] BCD
 [Display Type] DEC(w/ -sign, w/ +sign)

Available Memory

○ C

Memory	TYPE	Remarks
DM (data memory)	0	
CH (input/output relay)	1	
HR (holding relay)	2	
LR (latch relay)	3	
AR (alarm relay)	4	
T (timer/current value)	5	
C (counter/current value)	6	
EMn (extensional data memory)	7	* 1
TU (timer/contact)	9	Read only
CU (counter/contact)	10	Read only

○ CV

Memory	TYPE	Remarks
DM (data memory)	0	
CH (input/output relay)	1	
AR (alarm relay)	4	
T (timer/current value)	5	
C (counter/current value)	6	
EMn (extensional data memory)	7	* 1
TU (timer/contact)	9	Read only
CU (counter/contact)	10	Read only

○ CS1

Memory	TYPE	Remarks
DM (data memory)	0	
CH (input/output relay)	1	
AR (alarm relay)	4	
T (timer/current value)	5	
C (counter/current value)	6	
EMn (extensional data memory)	7	* 1
W (internal relay)	8	
TU (timer/contact)	9	Read only
CU (counter/contact)	10	Read only

*1 When using EMn (extensional data memory), specify the bank number (C, CV:0 ~ 7, CS1:0 ~ C).
The assigned memory is indicated while editing the screen as illustrated:

<E.g.> EM0:30000

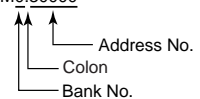

**Set the memory to the extent of the memory range of each PLC model.
Use TYPE number to assign indirect memory for macro programs.**

Wiring

The following is a diagram to show the wiring of the cable which connects V6 to PLC.

RS-232C

Wiring Diagram 1

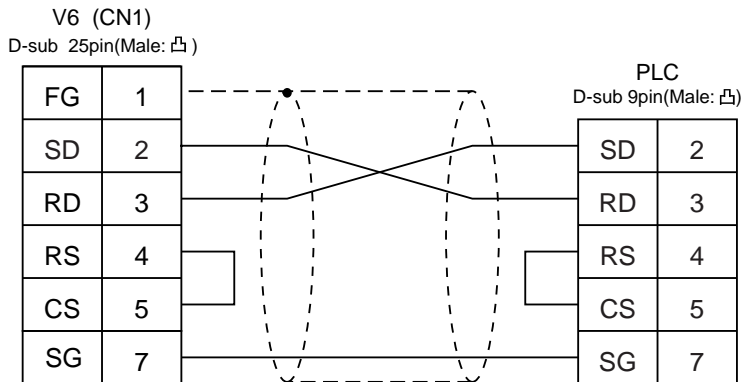

* Use twist shielded cables.

Wiring Diagram 2

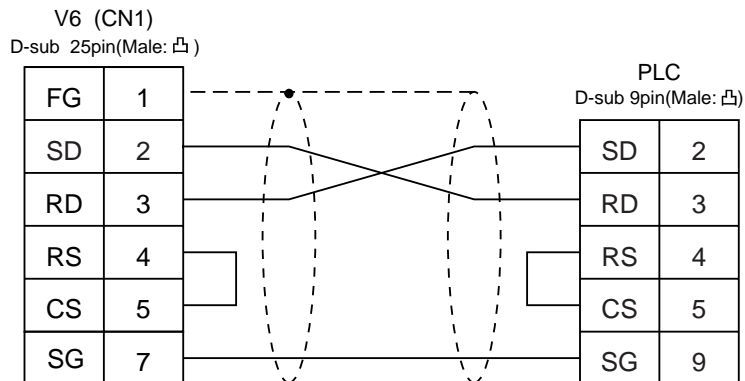

* Use twist shielded cables.

Wiring Diagram 3

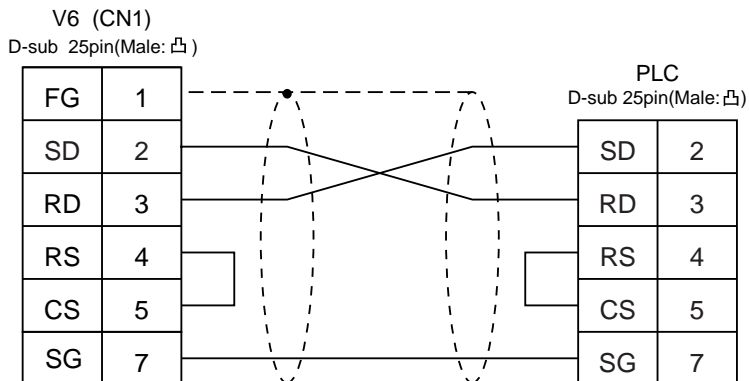

*Use twist shielded cables.

RS-422

Wiring Diagram 4

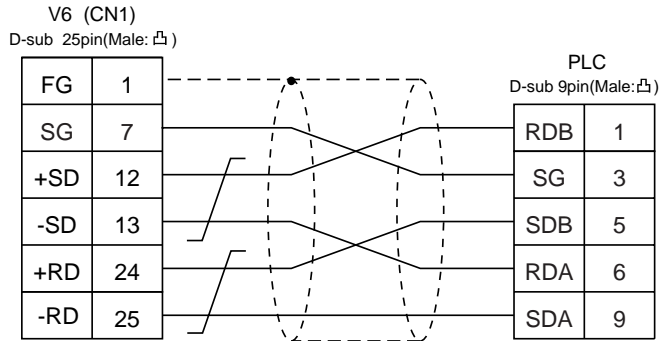

*Use twist shielded cables.

Wiring Diagram 5

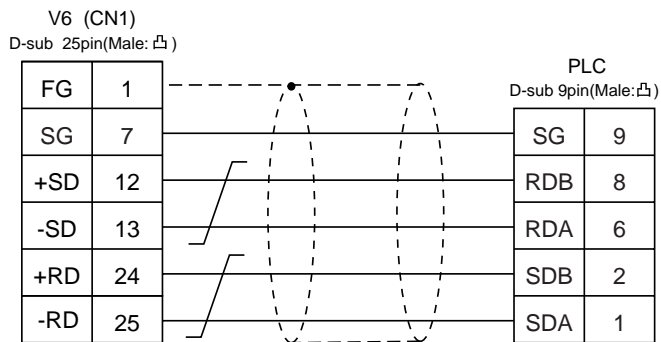

* Use twist shielded cables.

Wiring Diagram 6

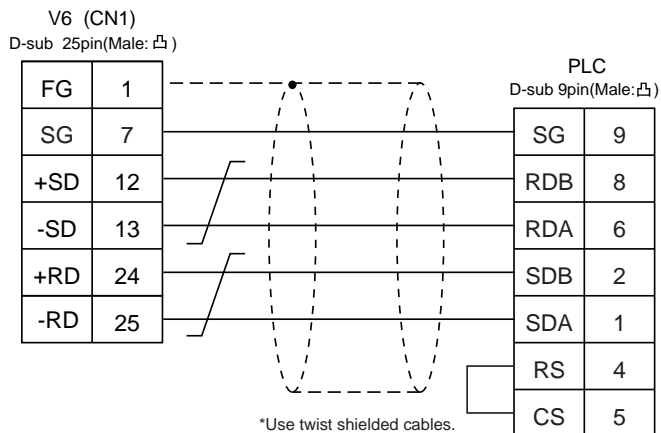

*Use twist shielded cables.

Wiring Diagram 7

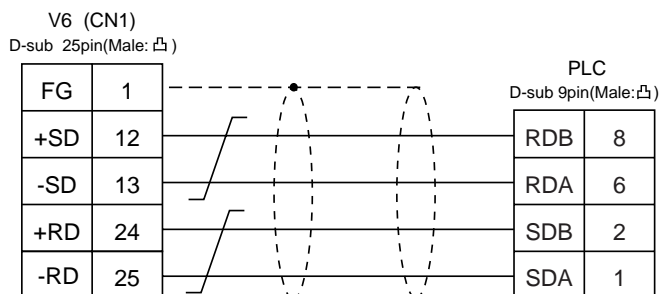

*Use twist shielded cables.

8 OMRON PLC • 2

(OMRON-CS1 DNA)

When connect the V6 to CS1 on a network, the V6 can also access the other CS1 on a network.

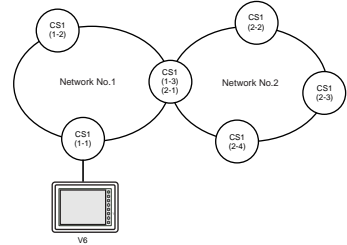

Available PLC

Select PLC Type	PLC	Link Unit	Wiring Diagram (refer to P2-25,26)
SYSMAC CS1 DNA	CS1	CPU unit with a built-in RS-232C port (host link port)	RS-232C [Wiring Diagram 2]
		CS1W-SCU21	RS-232C [Wiring Diagram 2]
		Communication board (CS1W-SCB41)	RS-232C [Wiring Diagram 2] RS-422 [Wiring Diagram 7] *1

*1 Cannot be connected to V6 by multi-link connection.

Available Memory

See [Available Memory] of CS1 in [7 OMRON PLC • 1].

Wiring

See [Wiring] in [7 OMRON PLC • 1].

V-SFTE Setting

- Select [System Setting] from [Item], and click [Comm. Parameter]. The [Comm. Parameter] dialog is displayed. Set [Connection] to [1:n] in the [Detail] tab window.
- Select [System Setting] from [Item], and click [Network Table]. [Edit Network Table] is displayed. Double click the [No.]. The dialog is displayed. Register the CS1 on the network.

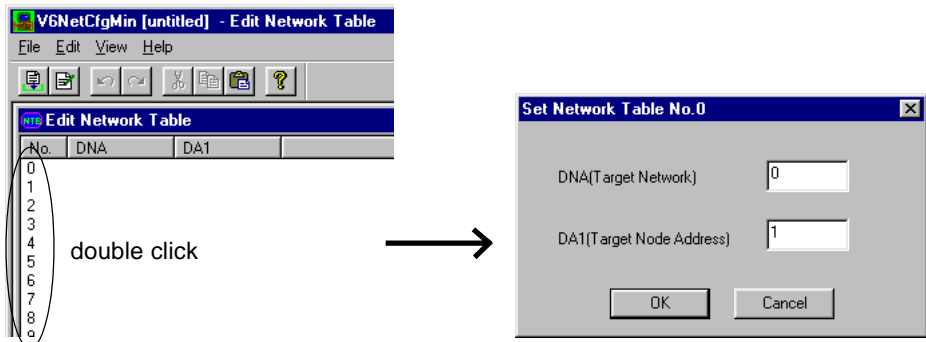

9 Sharp PLC • 1

Available PLC

Select PLC Type	PLC	Link Unit	Wiring Diagram refer to P2-30
JW series	JW50, JW70, JW100 JW50H, JW70H JW100H	ZW-10CM JW-10CM	RS-422 [Wiring Diagram 3]
	JW20 JW-31CUH	JW-21CM	RS-422 [Wiring Diagram 3]
JW100/70H COM port	JW70, JW100 JW70H, JW100H	CPU communication port	RS-232C [Wiring Diagram 1] RS-422 [Wiring Diagram 2]
JW20 COM port	JW20(JW22CU) JW20H(JW22CU)		

Communication Setting

The recommended communication parameter setting of both PLC and V6 is as follows:

Item	Setting of PLC	Comm. Parameter of V6
Baud Rate	19200bps	19200bps
Port	0 for STA. NO x10, 1 for x1	0
Parity	Even	Even
RS-422	4-wire system (fixed)	—————
Data Length	7	7
Stop Bit	2	2
Error Check	Sumcheck (fixed)	—————
Transmission Control	Command mode (fixed)	—————

Switch Setting of Link Unit

Baud rate: 19200bps

Switch	Setting	Contents
SW0	4	Command mode
SW1	1	Station address (lower half)
SW2	0	Station address (upper half)
SW3-1	OFF	Not used
SW3-2	ON	4-wire system
SW3-3	OFF	Not used
SW3-4	ON	Even parity
SW4	0	Baud rate 0: 19200 1: 9600 2: 4800 3: 2400 4: 1200 5: 600
SW7	ON	Terminating resistance provided

PLC System Memory Setting (in case of a communication port)

Baud rate: 19200bps

System memory		D7	D6	D5	D4	D3	D2	D1	D0
	#0236	0	0	1	1	0	0	0	0
	#0237	0	0	0	0	0	0	0	1

Available Memory

Memory	TYPE	Remarks
X9XXX (register)	0	
XXXXX (relay)	1]as word device
EXXXX (self-diagnosis)	2	
bXXXX (timer counter)	3	
Fn (file register)	7	*1

*1 To set up Fn (file register), input [File No.] + [: (colon)] + [address].

<E.g.> F1 : 00002

Set the memory to the extent of the memory range of each PLC model.

Use TYPE number to assign indirect memory for macro programs.

Wiring

The following is a diagram to show the wiring of the cable which connects V6 to PLC.

RS-232C

Wiring Diagram 1

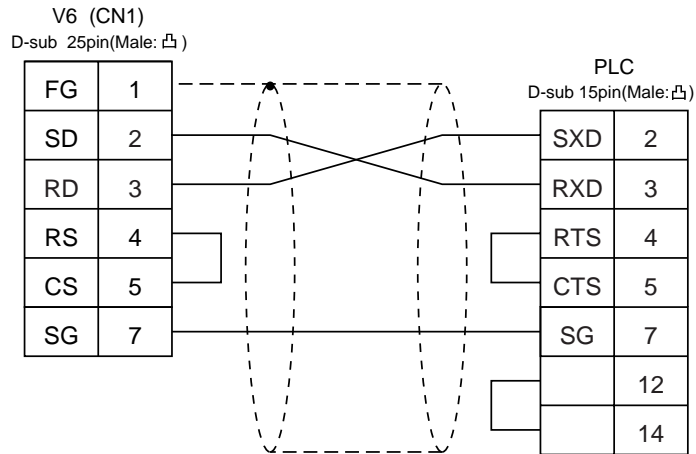

* Use twist shielded cables.

RS-422

Wiring Diagram 2

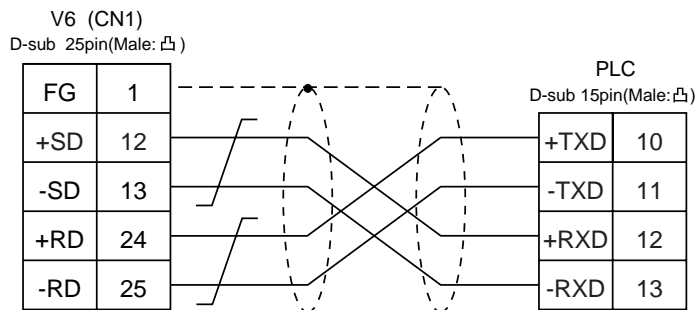

*Use twist shielded cables.

Wiring Diagram 3

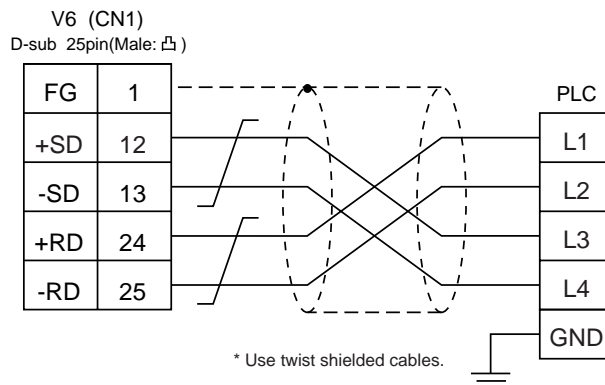

* Use twist shielded cables.

10 Sharp PLC • 2

(JW-32CUH/33CUH)

Available PLC

Select PLC Type	PLC	Link Unit	Wiring Diagram (refer to P2-32)
JW20 COM port	JW-32CUH JW-33CUH	Communication port on a CPU unit	RS-232C PG/COMM2 [Wiring Diagram 1] RS-422 PG/COMM1 [Wiring Diagram 2] PG/COMM2 [Wiring Diagram 2]

Communication Setting

The recommended communication parameter setting of both PLC and V6 is as follows:

Item	Setting of PLC	Comm. Parameter of V6
Baud Rate	19200bps	19200bps
Port	1	1
Parity	Even	Even
RS-422	4-wire system (fixed)	_____
Data Length	7	7
Stop Bit	2	2
Error Check	Sumcheck (fixed)	_____
Transmission Control	Command mode (fixed)	_____

PLC System Memory Setting (in case of a communication port)

Set communication condition in the system memory #234/235(for PG/COMM port 1) or #236/237(for PG/COMM port 2) to communicate with a personal computer.

Available Memory

Memory	TYPE	Remarks
X9XXX (register)	0	
XXXXX (relay)	1]as word device
EXXXX (self-diagnosis)	2	
bXXXX (timer counter)	3	
Fn (file register)	7	*1

*1 To set up Fn (file register), input [File No.] + [: (colon)] + [address].

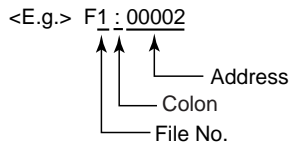

**Set the memory to the extent of the memory range of each PLC model.
Use TYPE number to assign indirect memory for macro programs.**

Wiring

The following is a diagram to show the wiring of the cable which connects V6 to PLC.

RS-232C

Wiring Diagram 1

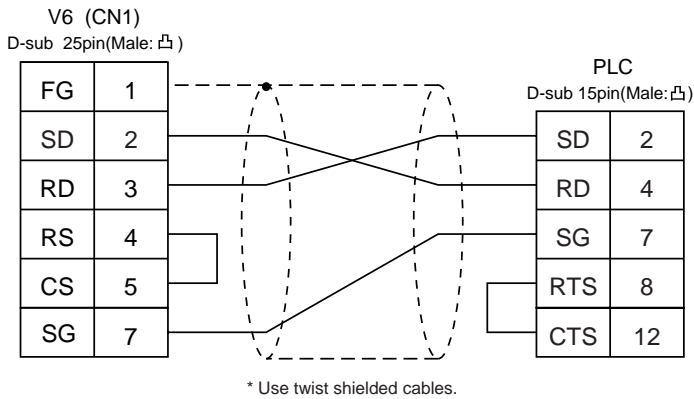

RS-422

Wiring Diagram 2

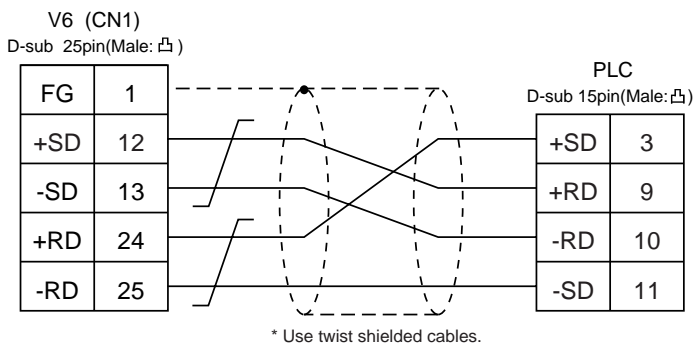

11 HITACHI PLC • 1

(HIDIC H series)

Available PLC

Select PLC Type	PLC	Link Unit	Wiring Diagram (refer to P2-35)
HIDIC-H	HIDIC H series CPU	COMM-2H	RS-232C [Wiring Diagram 1] RS-422 [Wiring Diagram 2]
		PERIPHERAL port on a CPU module	RS-232C [Wiring Diagram 1]
		EH150	*1 [EH-RS05] cable made by HITACHI + RS-232C [Wiring Diagram 1]
		H-252C on a CPU module	PERIPHERAL 1 RS-232C [Wiring Diagram 1] PERIPHERAL 2 *2 [CNCOM-05] cable made by HITACHI + RS-232C [Wiring Diagram 1]

*1 When using [EH-RS05] cable made by HITACHI, connect the cable of [Wiring Diagram 1] to the D-sub 15 pins side of [EH-RS05] to communicate with V6.

*2 When using [CNCOM-05] cable made by HITACHI, connect the cable of [Wiring Diagram 1] to the D-sub 15 pins side of [CNCOM-05] to communicate with V6.

Communication Setting

The recommended communication parameter setting of both PLC and V6 is as follows:

◆COMM-2H

Item	Setting of PLC	Comm. Parameter of V6
Baud Rate	19200bps	19200bps
Port	0 for both STATION x10 and x1	0
Parity	Even	Even
Transmission Control Mode ^{*1}	RS-232C	MODE7 Protocol 2 w/ Port
	RS-422	MODE9 Protocol 2 w/ Port
Transmission Code	Data Length	7 (ASCII)
	Stop Bit	1
Sumcheck	Provided (fixed)	_____

If "Transmission control mode" is any other type except the above, specify "Transmission control mode" as below.

		Setting of PLC	Comm. Parameter of V6
Transmission Control Mode	RS-232C	MODE1 MODE2 MODE9	Protocol 1 w/o Port Protocol 1 w/ Port Protocol 2 w/o Port
	RS-422	MODE2	Protocol 1 w/ Port ^{*1}

*1 Cannot be connected to V6 by multi-link connection.

◆CPU module

Peripheral port is only available with "pattern 1."

Switch Setting

Baud rate : 19200bps

MODE switch : To connect to both RS-232C and RS-422, set MODE switch to 9.
RS-232C(pattern 2, w/o port) RS-422(pattern 2, with port)

ST No. switch : Choose "0" for both X10 and X1.

Dip Switch

Switch	Setting	Contents
1	OFF	Bit length
2	OFF	Same as V6 (normally 19200bps)
3	ON	
4	ON	
5	ON	Parity provided
6	ON	Even
7	OFF	Stop bit 1
8	ON	Sumcheck provided

Available Memory

Memory	TYPE	Remarks
WR (internal word output)	0	
X (external bit input)	1	WX as word device
Y (external bit output)	2	WY as word device
L (bit CPU link area)	3	WL as word device
M (bit data area)	4	WM as word device
TC (timer counter/elapsed time)	5	
R (relay)	6	
TD (timer counter/contact)	7	
WN (network input output)	8	

Set the memory to the extent of the memory range of each PLC model.

Use TYPE number to assign indirect memory for macro programs.

Wiring

The following is a diagram to show the wiring of the cable which connects V6 to PLC.

RS-232C

Wiring Diagram 1

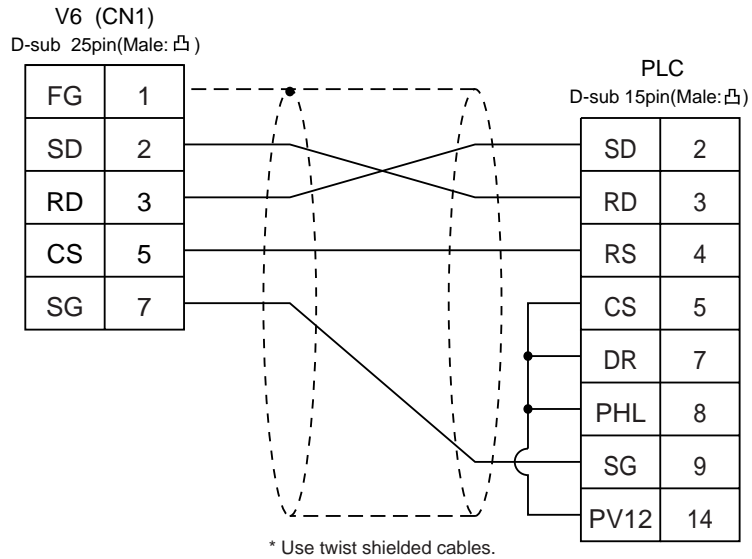

RS-422

Wiring Diagram 2

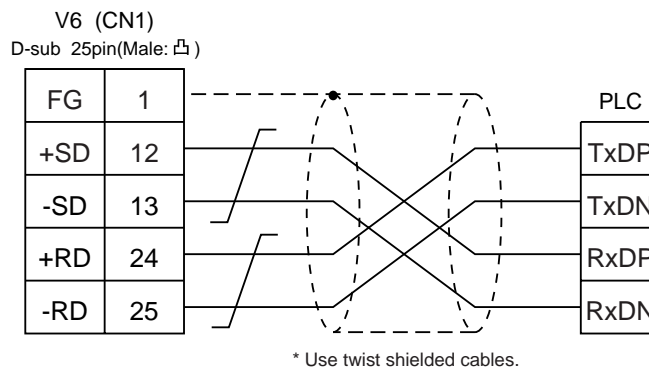

12 HITACHI PLC • 2

(HIDIC-S10 α)

Available PLC

Host Link H-7338

Select PLC Type	PLC	Link Unit	Wiring Diagram (refer to P2-37,38)
HIDIC-S10/2alpha	S10 2 α	Port on a CPU unit	RS-422 [Wiring Diagram 3]
	S10 mini	RS-232C on a CPU unit	RS-232C [Wiring Diagram 1]
		LQE060	RS-232C [Wiring Diagram 2]
HIDIC-S10/ABS	ABS ^{*1}	—————	RS-422 [Wiring Diagram 3]

*1 Specify the memory by absolute addresses. For further information, refer to the relevant PLC manual.

Communication Setting

The recommended communication parameter setting of both PLC and V6 is as follows:

Item	Setting of PLC	Comm. Parameter of V6
Baud Rate	7	19200bps

Available Memory

○ HIDIC-S10 2 α

Memory	TYPE	Remarks
FW (work register)	0	
X (input relay)	1	XW as word device
Y (output relay)	2	YW as word device
R (internal relay)	3	RW as word device
G (global link)	4	GW as word device
K (keep relay)	5	KW as word device
T (on-delay timer contact)	6	TW as word device
U (one shot timer contact)	7	UW as word device
C (up/down counter contact)	8	CW as word device
TS (on-delay timer set value)	9	
TC (on-delay timer elapsed value)	10	
US (one shot timer set value)	11	
UC (one shot timer elapsed value)	12	
CS (up/down counter set value)	13	
CC (up/down counter elapsed value)	14	
DW (data register)	15	

E (event register)	16	EW as word device
S (system register)	17	SW as word device
J (transfer register)	18	JW as word device
Q (resive register)	19	QW as word device
M (extensional internal register)	20	MW as word device

○ HIDIC ABS

Memory	TYPE	Remarks
0E	0	
06	1	
18	2	
19	3	
1A	4	
1B	5	
1C	6	
1D	7	

**Set the memory to the extent of the memory range of each PLC model.
Use TYPE number to assign indirect memory for macro programs.**

Wiring

The following is a diagram to show the wiring of the cable which connects V6 to PLC.

RS-232C

Wiring Diagram 1

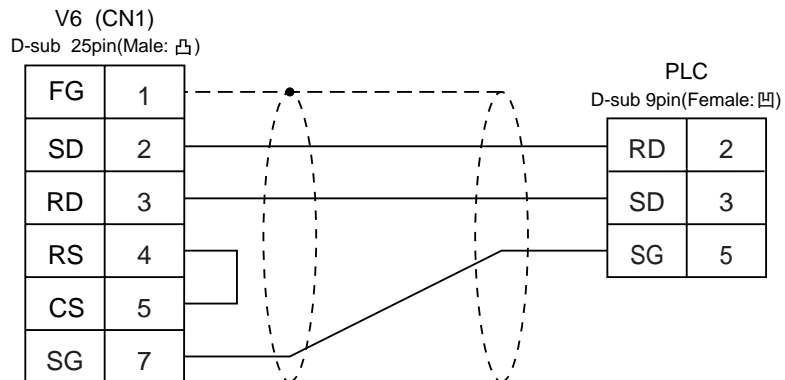

* Use twist shielded cables.

RS-232C

Wiring Diagram 2

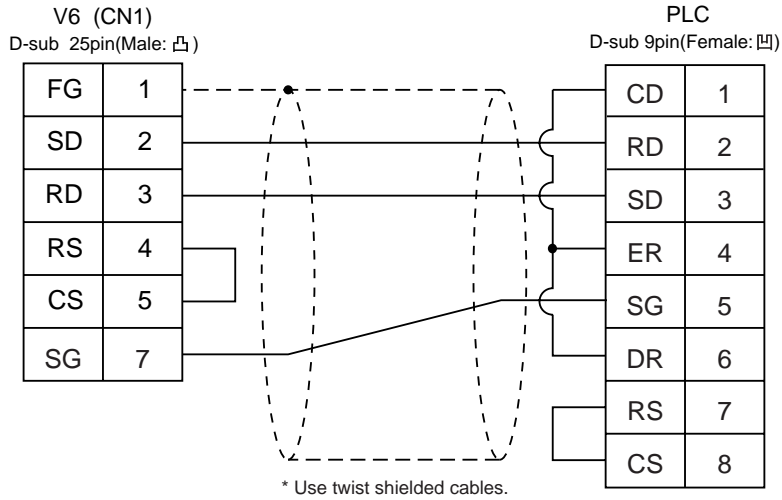

RS-422

Wiring Diagram 3

For connection to the S10X α series, use a 50 Ω (1/2W) resistance as shown below.

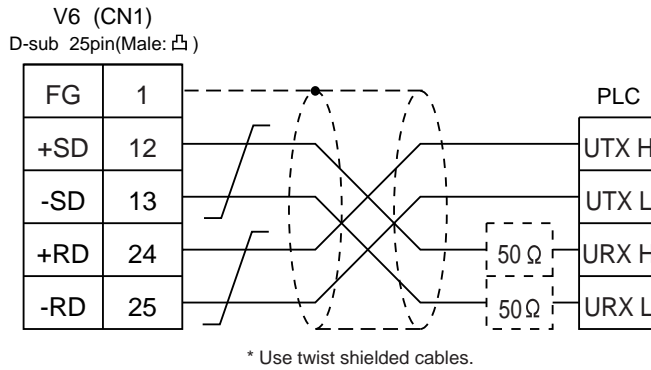

13 Matsushita PLC

Available PLC

Select PLC Type	PLC	Link Unit	Wiring Diagram (refer to P2-41)
MEWNET	FP1	RS-232C port on a CPU unit	RS-232C [Wiring Diagram 1]
	FP3	AFP3462	RS-232C [Wiring Diagram 1]
		AFP3463	RS-422 [Wiring Diagram 4]
	FP5	AFP5462	RS-232C [Wiring Diagram 1]
	FP10	RS-232C port on a CPU unit	RS-232C [Wiring Diagram 1]
		AFP5462	RS-232C [Wiring Diagram 1]
	FP10S	RS-232C port on a CPU unit	RS-232C [Wiring Diagram 1]
		AFP3462	RS-232C [Wiring Diagram 1]
		AFP3463	RS-422 [Wiring Diagram 4]
	FP0	RS-232C tool port on a CPU unit	RS-232C cable made by Matsushita AFC8513
		RS-232C port on a CPU unit	RS-232C [Wiring Diagram 3]
	FP2	RS-232C tool port on a CPU unit	RS-232C cable made by Matsushita AFC8513
		RS-232C port on a CPU unit	RS-232C [Wiring Diagram 2]

Communication Setting

The recommended communication parameter setting of both PLC and V6 is as follows:

Item		Setting of PLC	Comm. Parameter of V6
Baud Rate		19200bps	19200bps
Port		"0" for x10, "1" for x1	1
Parity		Even	Even
Transmission Code	Data Bit	7 (ASCII)	7
	Stop Bit	1	1
Transmission Control		Computer link system (fixed)	_____
Control Signal		Invalid (fixed)	_____

* If a tool port (the ladder port for RS-232C) of FP0 is used, the range of PLC parameter setting is limited as below. Adjust PLC parameter setting to comm. parameter setting of V6.

Baud rate : 9600, 19200bps
 Parity : Odd (fixed)
 Data bit : 8 (7 can be selected. Normally 8.)
 Stop bit : 1 (fixed)

Switch Setting of Link Unit

No	Setting	Contents
1	ON	Same as V6 (normally 19200bps)
2	OFF	
3	OFF	
4	OFF	Data length 7
5	ON	Parity provided
6	ON	Even
7	OFF	Stop bit 1
8	OFF	CS, CD invalid

Available Memory

Memory	TYPE	Remarks
DT (data register)	0	
X (external input relay)	1	WX as word device, read only
Y (external output relay)	2	WY as word device
R (internal relay)	3	WR as word device, special relay included
L (link relay)	4	WL as word device
LD (link register)	5	
FL (file register)	6	
SV (timer/counter set value)	7	
EV (timer/counter elapsed value)	8	
T (counter/contact)	9	Read only
C (counter/contact)	10	Read only

Set the memory to the extent of the memory range of each PLC model.

Use TYPE number to assign indirect memory for macro programs.

Wiring

The following is a diagram to show the wiring of the cable which connects V6 to PLC.

RS-232C

Wiring Diagram 1

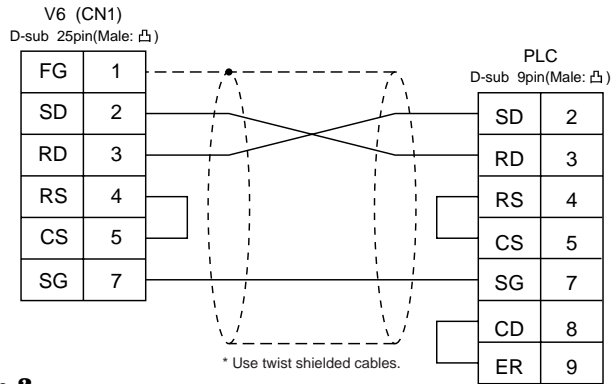

Wiring Diagram 2

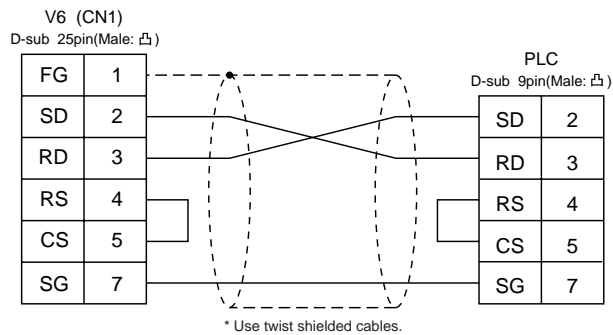

Wiring Diagram 3

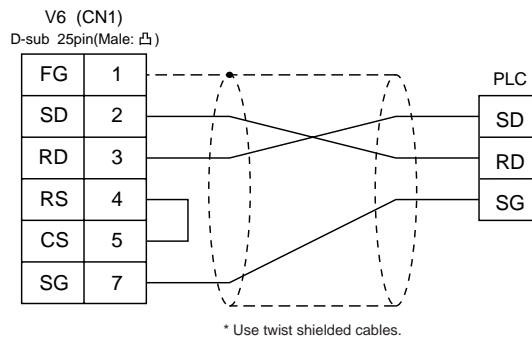

RS-422

Wiring Diagram 4

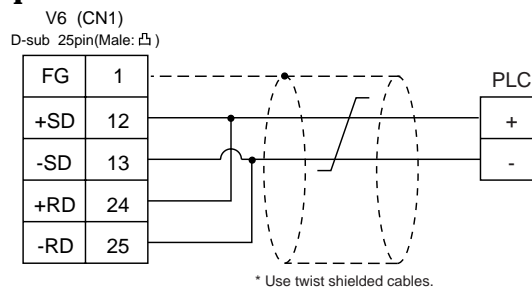

14 YOKOGAWA PLC • 1

(FA-500)

Available PLC

Select PLC Type	PLC	Link Unit	Wiring Diagram (refer to P2-43)
FA500	FA500	LC01-0N	RS-232C [Wiring Diagram 1]
		LC02-0N	RS-232C [Wiring Diagram 1] RS-422 [Wiring Diagram 2]

Communication Setting

The recommended communication parameter setting of both PLC and V6 is as follows:

Item	Setting of PLC	Comm. Parameter of V6
Baud Rate	19200bps	19200bps
Port	1	1
Parity	Even	Even
Transmission Code	Data Length	7
	Stop Bit	1
Sumcheck	Provided (fixed)	_____
Terminal Character	None (fixed)	_____
Protection Function	None (fixed)	_____

Available Memory

Memory	TYPE	Remarks
D (data register)	0	
B (common register)	1	
TP (timer/current value)	2	
TS (timer/set value)	3	
CP (counter/current value)	4	
CS (counter/set value)	5	
X (input relay)	6	
Y (output relay)	7	
I (internal relay)	8	
E (external relay)	9	

Set the memory to the extent of the memory range of each PLC model.

Use TYPE number to assign indirect memory for macro programs.

Wiring

The following is a diagram to show the wiring of the cable which connects V6 to PLC.

RS-232C

Wiring Diagram 1

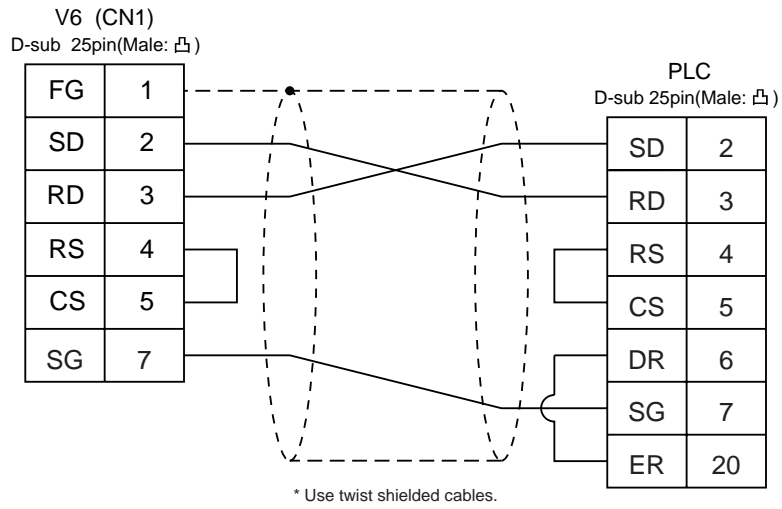

RS-422

Wiring Diagram 2

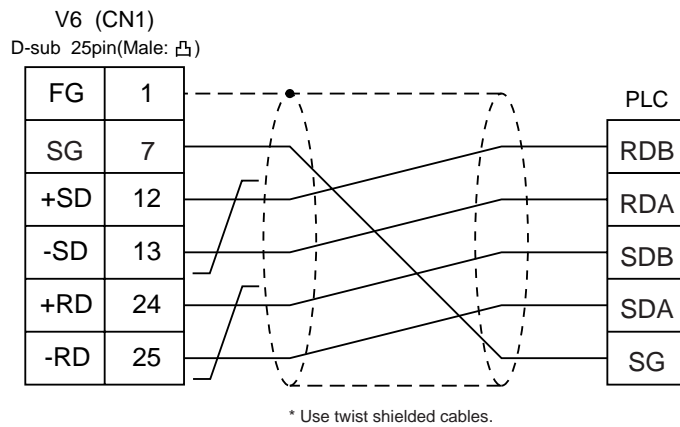

15 YOKOGAWA PLC • 2

(FA-M3/FA-M3R)

Available PLC

Select PLC Type	PLC	Link Unit	Wiring Diagram (refer to P2-46)
FA-M3	FA-M3	Programming tool port on a CPU module *1	Cable made by YOKOGAWA [KM11-2N]
		F3LC01-1N *2	RS-232C [Wiring Diagram 1]
		F3LC11-1N	RS-232C [Wiring Diagram 1]
		F3LC11-2N	RS-422 [Wiring Diagram 2]
FA-M3R	FA-M3 R	Programming tool port on a CPU module	Cable made by YOKOGAWA [KM11-2N]
		F3LC12-1F	RS-232C [Wiring Diagram 1]

*1 CPU types which can be connected directly to programming tool port on a CPU module are "F3SP21-0N," "F3SP25-2N" and "F3SP35-5N."

*2 When the link unit, F3LC01-1N, is used, the communication setting and available memory are the same as the contents of "12 YOKOGAWA PLC • 1(FA-500)," provided that B (common register) cannot be used.

Communication Setting

The recommended communication parameter setting of both PLC and V6 is as follows:

Item	Setting of PLC	Comm. Parameter of V6
Baud Rate	19200bps	19200bps
Parity	Even	Even
Transmission Code	Data Length	7
	Stop Bit	1
Sumcheck	Provided	Provided
Terminal Character	None (fixed)	_____
Protection Function	None (fixed)	_____

* When using programming tool port on a CPU module for direct connection to V6, set [Data Length] as [8-bit] in the [comm. Parameter] dialog of V6 because data length "8" is fixed. Also, specify the "CPU Communication Port" setting of "Configuration" in the ladder making tool as follows.

Personal Computer Link Function : Use

Available Memory

Memory	TYPE	Remarks
D (data register)	0	
R (common register)	1	
V (index register)	2	
W (link register)	3	
Z (special register)	4	
TP (down timer current value)	5	
TS (timer set value)	6	Read only
CP (down counter current value)	7	
CS (down counter set value)	8	
X (input relay)	9	
Y (output relay)	10	
I (internal relay)	11	
E (common relay)	12	
L (link relay)	13	
M (special relay)	14	
B (file register)	15	

- * The CPU No. is required in addition to the memory type/address. The assigned memory is indicated while editing the screen as illustrated:

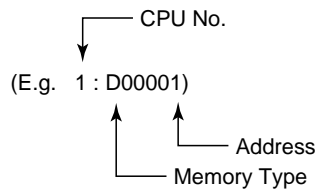

Set the memory to the extent of the memory range of each PLC model.
Use TYPE number to assign indirect memory for macro programs.

Wiring

The following is a diagram to show the wiring of the cable which connects V6 to PLC.

RS-232C

Wiring Diagram 1

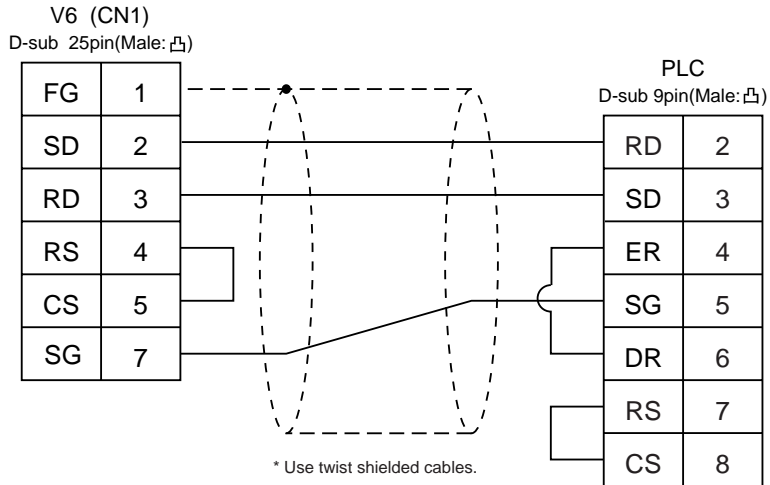

RS-422

Wiring Diagram 2

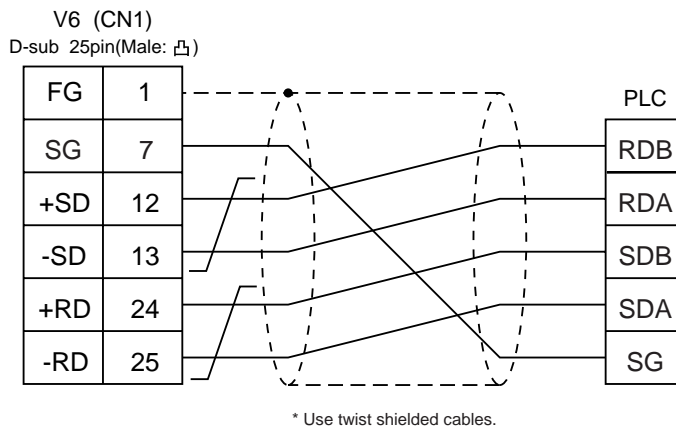

16 YASKAWA PLC • 1

Available PLC

Select PLC Type	PLC	Link Unit	Wiring Diagram (refer to P2-48, 49)
Memobus	GL60 series	JAMSC-IF60 JAMSC-IF61 JAMSC-IF611	RS-232C [Wiring Diagram 1]
		JAMSC-IF612 JAMSC-IF613	RS-422 [Wiring Diagram 3]
	GL120, GL130 series	Memobus port on a CPU module	RS-232C [Wiring Diagram 1]
		JAMSC -120NOM27100	RS-422 [Wiring Diagram 4]
PROGIC-8	PORT2 on a CPU unit	RS-232C [Wiring Diagram 2]	

* Other kinds of MEMOBUS unit can be connected.

Communication Setting

The recommended communication parameter setting of both PLC and V6 is as follows:

Item	Setting of PLC	Comm. Parameter of V6
Baud Rate	19200bps	19200bps
Port	1	1
Parity	Even	Even
Transmission Code	Data Length	8 bit RTU
	Stop Bit	1
Error Check	CRC (fixed)	_____
Port Delay Timer	0 (fixed)	_____

Select [TYPE 1] or [TYPE 2] from [Trans. Mode] in [Comm. Parameter] of the V-SFTE.

PLC Type	Setting of V6	Contents
GL60 series, PROGIC-8	Type 1	Same as before
GL120/130 series	Type 2	Standard binary mode

Available Memory

Memory	TYPE	Remarks
4 (word device)	0	
3 (input register)	1	Constant register included Read only
R (link register)	2	
A (extension register)	3	
0 (coil)	4	
D (link coil)	5	
1 (input relay)	6	Read only
7 (constant register)	7	

Set the memory to the extent of the memory range of each PLC model.
Use TYPE number to assign indirect memory for macro programs.

Wiring

The following is a diagram to show the wiring of the cable which connects V6 to PLC.

RS-232C

Wiring Diagram 1

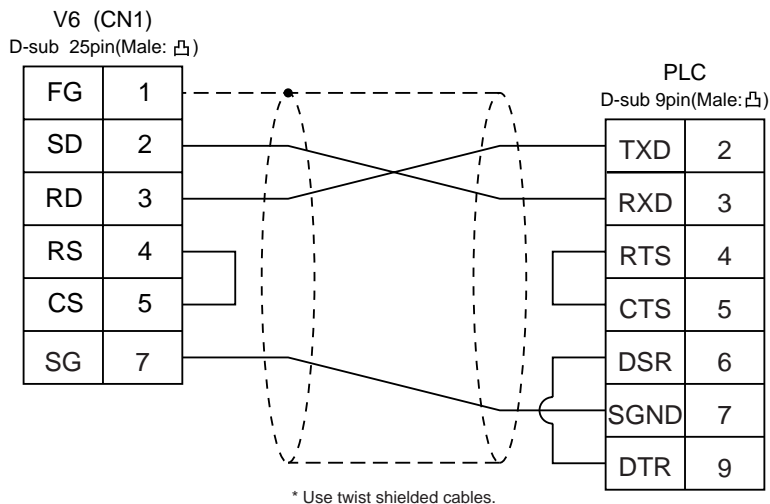

Wiring Diagram 2

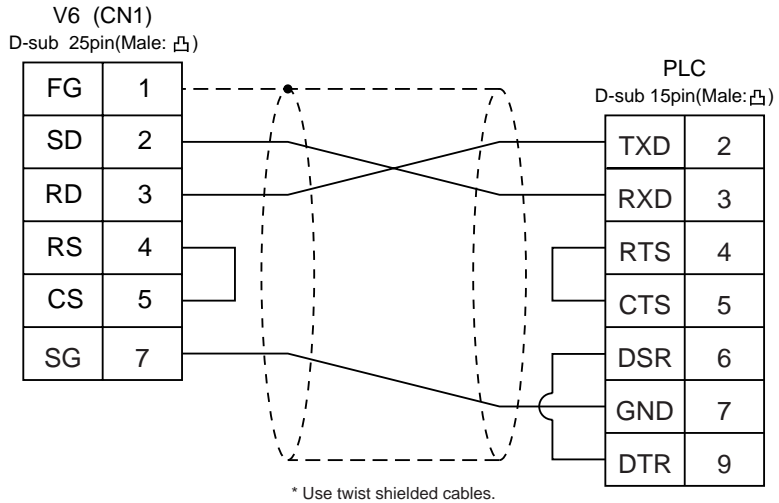

RS-422

Wiring Diagram 3

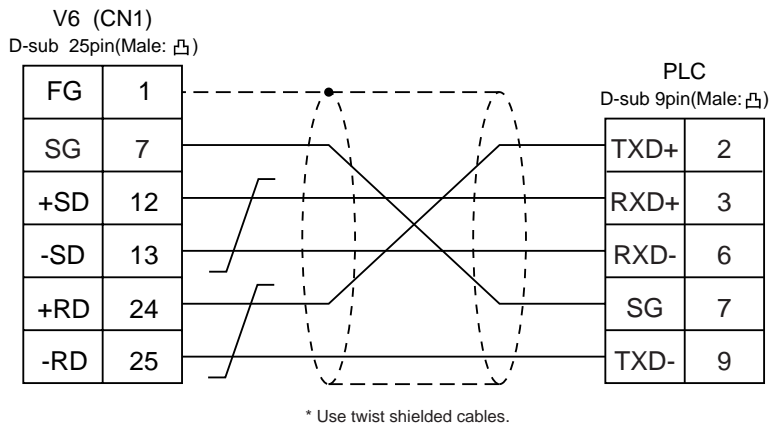

Wiring Diagram 4

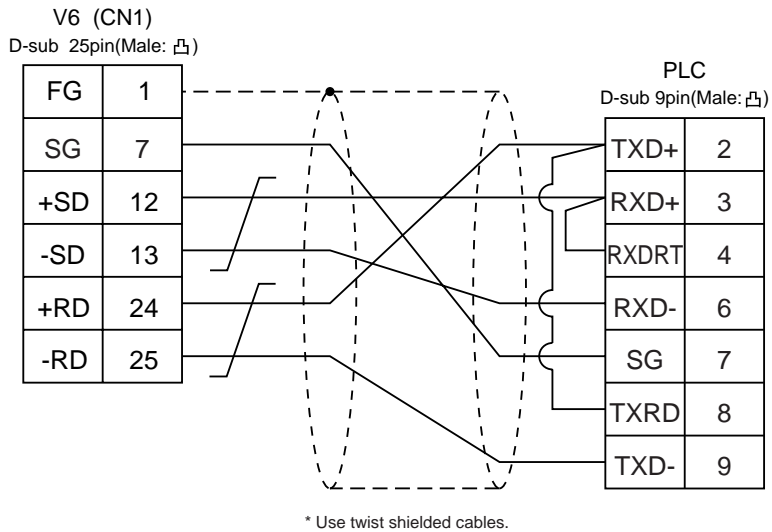

17 YASKAWA PLC • 2

Available PLC

Select PLC Type	PLC	Link Unit	Wiring Diagram (refer to P2-51)
CP9200SH /MP900	CP9200SH	CP217IF	RS-232C [Wiring Diagram 1] [Wiring Diagram 2]
			RS-422 [Wiring Diagram 3]
	MP920 MP930	Memobus port on a CPU module	RS-232C [Wiring Diagram 1]
			217IF

Communication Setting

The recommended communication parameter setting of both PLC and V6 is as follows:

Item		Setting of PLC	Comm. Parameter of V6
Baud Rate		19200bps	19200bps
Port		1	1
Parity		Even	Even
Transmission Code	Data Length	8	8
	Stop Bit	1	1
Error Check		CRC (fixed)	_____
Port Delay Timer		0 (fixed)	_____

Available Memory

Memory	TYPE	Remarks
MW (holding register)	0	
IW (input register)	1	Read only
MB (coil)	4	
IB (input relay)	6	Read only

When setting the MB/IB memories, set the bit No. by HEX.

MBxxx
 DEC
 Bit No. : HEX

Set the memory to the extent of the memory range of each PLC model.

Use TYPE number to assign indirect memory for macro programs.

Wiring

The following is a diagram to show the wiring of the cable which connects V6 to PLC.

RS-232C

Wiring Diagram 1

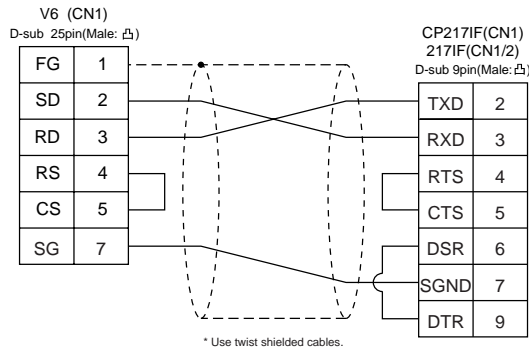

Wiring Diagram 2

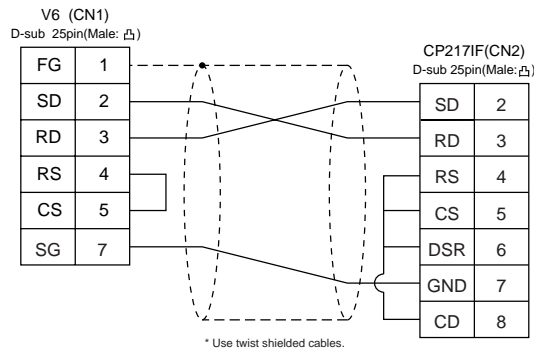

RS-422

Wiring Diagram 3

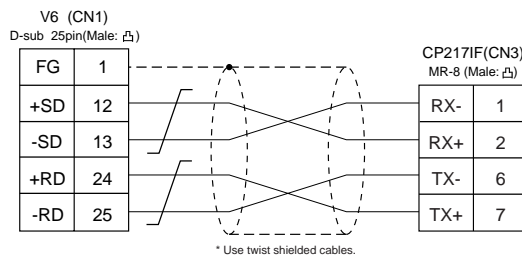

Wiring Diagram 4

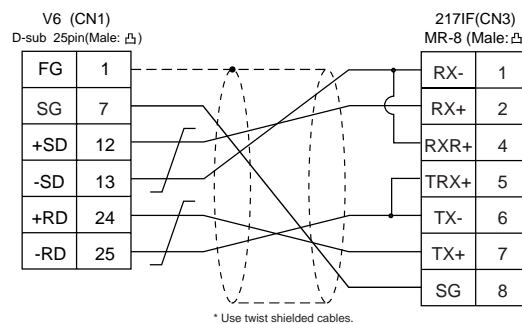

18 TOYOPUC PLC

Available PLC

Select PLC Type	PLC	Link Unit	Wiring Diagram (refer to P2-54)
TOYOPUC	L2/PC2 series PC3J	CMP-LINK	RS-422 [Wiring Diagram 1]

Communication Setting

The recommended communication parameter setting of both PLC and V6 is as follows:

Item	Setting of PLC	Comm. Parameter of V6
Baud Rate	19200bps	19200bps
Port	0	0
Parity	Even	Even
Transmission Code	Data Length	7
	Stop Bit	2

Set the [Trans. Mode] for [Detail] in the [Comm. Parameter].

- PC3J : Select [Single Data Area] or [Split Data Area].
- L2/PC2 series : Select [Single Data Area].

Trans. Mode	Contents
Single Data Area	Data area is common.
Split Data Area	Divide each PLC device into a program file.

Switch Setting

Baud rate: 19200bps

Switch	Setting	Contents
SW1	0	Station address (lower half)
SW2	0	Station address (upper half)
SW3	1	Baud rate 1 : 19200 2 : 9600 3 : 4800 4 : 2400 5 : 1200 6 : 600

Switch	Short bar	Contents
SET2	Provided	Data bit 7
SET3	Provided	Stop bit 2

Available Memory

Memory	TYPE	Remarks
D (data register)	0	
R (link register)	1	
B (file register)	2	
N (current value register)	3	
X (input relay)	4	WX as word device
Y (output relay)	5	WY as word device
M (internal relay)	6	WM as word device
K (keep relay)	7	WK as word device
L (link relay)	8	WL as word device
T (timer/contact)	9	WT as word device
C (counter/contact)	10	WC as word device
U (extensional data register)	11	
H (extensional set value register)	12	
EN (extensional current value register)	13	
EX (extensional input relay)	14	WEX as word device
EY (extensional output relay)	15	WEY as word device
EM (extensional internal relay)	16	WEM as word device
EK (extensional keep relay)	17	WEK as word device
EL (extensional link relay)	18	WEL as word device
ET (extensional timer/contact)	19	WET as word device
EC (extensional counter/contact)	20	WEC as word device
V (special register)	21	WV as word device

Set the memory to the extent of the memory range of each PLC model.

Use TYPE number to assign indirect memory for macro programs.

Wiring

The following is a diagram to show the wiring of the cable which connects V6 to PLC.

RS-422

Wiring Diagram 1

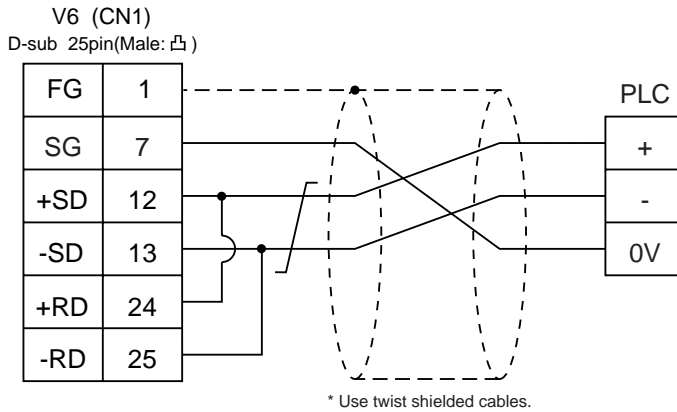

Screen Editing (Memory Input)

If [Split Data Area] is selected at the [Trans. Mode], the [PRG No] setting is available at the [Memory Input] dialog.

· range : 1~3

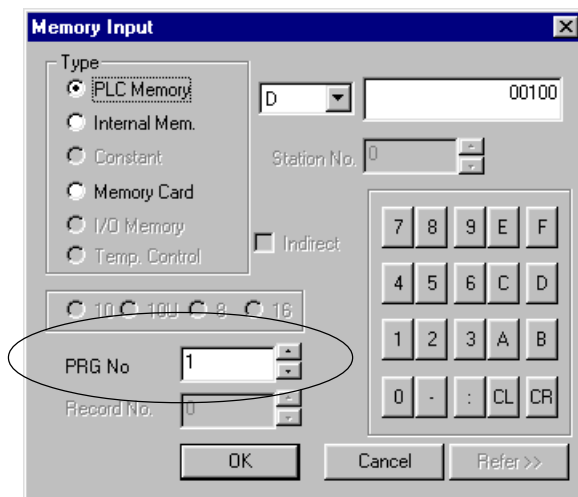

19 FUJI PLC • 1

(MICREX-F series)

Available PLC

Select PLC Type	PLC	Link Unit	Wiring Diagram (refer to P2-57)
MICREX-F series (MICREX-F series V4)	F55	NV1L-RS2	RS-232C [Wiring Diagram 1]
	F70, F70S	NC1L-RS2	RS-232C [Wiring Diagram 1]
		NC1L-RS4	RS-485 [Wiring Diagram 2]
	F80H, F120H, F120S F140S, F15□S	FFU120B FFK120A	RS-232C [Wiring Diagram 1] RS-485 [Wiring Diagram 2]

Communication Setting

The recommended communication parameter setting of both PLC and V6 is as follows:

Item	Setting of PLC	Comm. Parameter of V6
Baud Rate	19200bps	19200bps
Port	0	0
Parity	Even	Even
Transmission Control Mode	RS-232C	1 (Asynchronous non-protocol by command) (fixed)
	RS-422	3 (Asynchronous non-protocol by command) (fixed)
Transmission Code	Data Length	7 (ASCII)
	Stop Bit	1
Terminal Resistor at Receiver	Provided	

Switch Setting

MODE Switch: RS-232C: 1 RS-485: 3

RS-485 Port Setting SW: "0" for both x10, x1

RS-485 Terminal Resistor: ON

Character Switches

No	Setting	Contents
8	ON	Switch setting
7	ON	Parity provided
6	ON	Even
5	ON	7 bit
4	ON	1 bit
3	ON	Same as V6 (normally 19200bps)
2	ON	
1	OFF	

Available Memory

Memory	TYPE	Remarks
M (auxiliary relay)	0	WM as word device
K (keep relay)	1	WK as word device
B (input/output relay)	2	WB as word device
L (link relay)	9	WL as word device
F (special relay)	10	WF as word device
TS (timer/set value)	11	* 1
TR (timer/current value)	12	* 1
W9 (timer/current value 0.1)	13	* 1
CS (counter/set value)	14	* 1
CR (counter/current value)	15	* 1
BD (data memory)	16	* 1
WS (step control relay)	17	* 2
Wn (file memory)	18	* 3

*1 In case of the items which can display double word data (e.g. data display, graph, sampling), the data is managed as double word data.

Both bit data and word data are managed as lower-half 16 bits data.

Input: 16 upper-half bits are ignored. Output: "0" is written in the 16 upper-half bits.

*2 Byte device such as step relay is managed as follows;

Input: Write "0" in the 8 upper-half bits. Output: Write the data in the 8 lower-half bits.

*3 To set up Wn (file memory), input [File No.] + [: (colon)] + [address].

<E.g.> W30 : 00002

Set the memory to the extent of the memory range of each PLC model.

Use TYPE number to assign indirect memory for macro programs.

*** Notes on converting the data file of V4 (or GD-80) into the V6 data file**

When converting the data file of V4 (or GD-80) into the V6 data file, the PLC type is automatically selected as "MICREX-F series V4."

Wiring

The following is a diagram to show the wiring of the cable which connects V6 to PLC.

RS-232C

Wiring Diagram 1

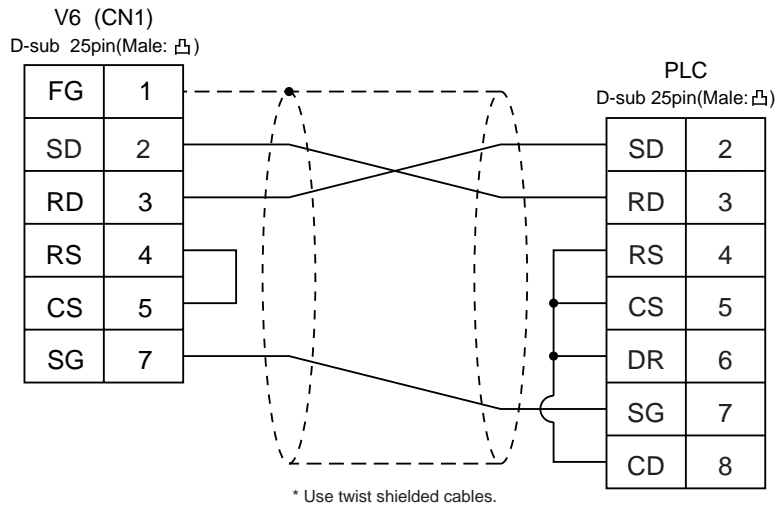

RS-485

Wiring Diagram 2

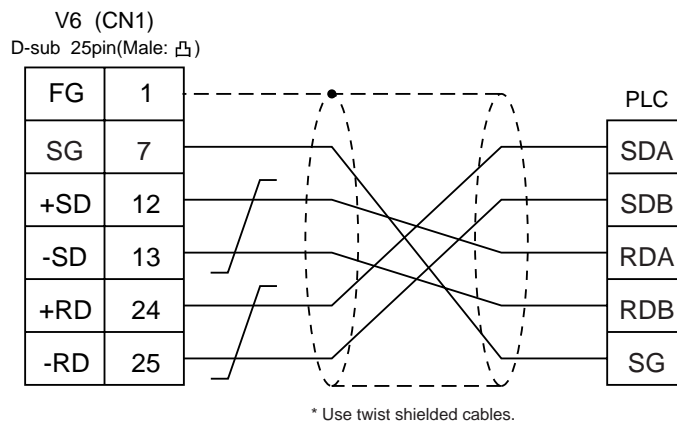

20 FUJI PLC • 2

(FLEX-PC series)

Available PLC

Select PLC Type	PLC	Link Unit	Wiring Diagram (refer to P2-60)
FLEX-PC Series ^{*1}	NS-T	NJRS-1	RS-232C [Wiring Diagram 1]
	NJ-T	NJRS-2	RS-232C [Wiring Diagram 1]
		NJRS-4	RS-485 [Wiring Diagram 2]

*1 When FLEX-PC TOYOTA version is used, select "FLEX-PC(T)" in [PLC Type].

Communication Setting

The recommended communication parameter setting of both PLC and V6 is as follows:

Item		Setting of PLC	Comm. Parameter of V6
Baud Rate		19200bps	19200bps
Port		0	0
Parity		Even	Even
Transmission Control Mode	RS-232C	1 (Asynchronous non-protocol by command) (fixed)	_____
	RS-422	3 (Asynchronous non-protocol by command) (fixed)	_____
Transmission Code	Data Length	7 (ASCII)	7
	Stop Bit	1	1
Terminal Resistor at Receiver		Provided	_____

Switch Setting

MODE Switch: RS-232C: 1 RS-485: 3
 RS-485 Port Setting SW: "0" for both x10, x1
 RS-485 Terminal Resistor: ON
 Character Switches

No	Setting	Contents
8	ON	Switch setting
7	ON	Parity provided
6	ON	Even
5	ON	7 bit
4	ON	1 bit
3	ON	Same as V6 (normally 19200bps)
2	ON	
1	OFF	

Available Memory

Standard Memory	TOYOTA Ver.	TYPE	Remarks
D (data register)	D	0	
W (link register)	R	1	
M (internal relay)	M	2	WM as word device
L (latch relay)	K	3	WL(WK) as word device
X (input relay)	X	4	WX as word device
Y (output relay)	Y	5	WY as word device
R (file register)	W	6	
TN (timer/current value)	TN	7	
CN (counter/current value)	CN	8	
T (timer/contact)	T	9	
C (counter/contact)	C	10	
WS (step relay)	-	11	

Set the memory to the extent of the memory range of each PLC model.
Use TYPE number to assign indirect memory for macro programs.

Wiring

The following is a diagram to show the wiring of the cable which connects V6 to PLC.

RS-232C

Wiring Diagram 1

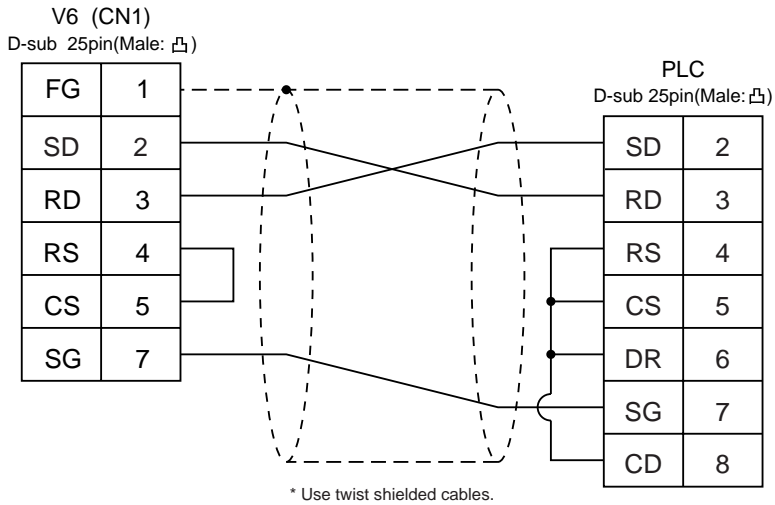

RS-485

Wiring Diagram 2

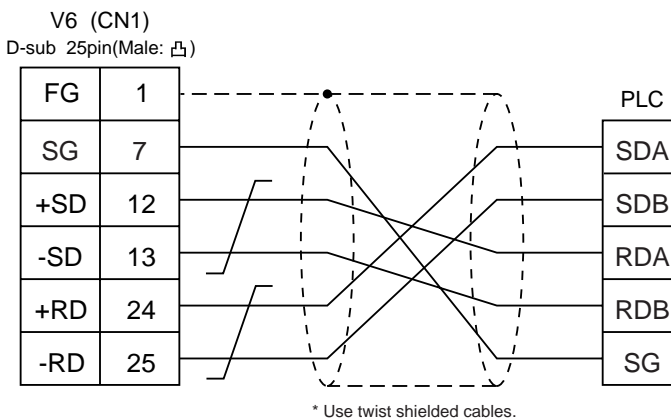

21 FUJI PLC • 3

(FLEX-PC CPU port)

Available PLC

Select PLC Type	PLC	Wiring Diagram (refer to P2-62)
*1 FLEX-PC CPU	FLEX-PC CPU	RS-485 [FU-CPUNS] made by HAKKO
	NJ-B16 RS-232C port	RS-232C [Wiring Diagram 1]

*1 When FLEX-PC CPU TOYOTA version is used, select "FLEX-PC CPU(T)" in [PLC Type].

Communication Setting

Connect to the CPU port. The communication parameter setting of V6 is done automatically.

Available Memory

Standard Memory	TOYOTA Ver.	TYPE	Remarks
D (data register)	D	0	
W (link register)	R	1	
M (internal relay)	M	2	WM as word device
L (latch relay)	K	3	WL(WK) as word device
X (input relay)	X	4	WX as word device
Y (output relay)	Y	5	WY as word device
R (file register)	W	6	
TN (timer/current value)	TN	7	
CN (counter/current value)	CN	8	
T (timer/contact)	T	9	
C (counter/contact)	C	10	
WS (step relay)	-	11	

Set the memory to the extent of the memory range of each PLC model.

Use TYPE number to assign indirect memory for macro programs.

Wiring

The following is a diagram to show the wiring of the cable which connects V6 to PLC.

RS-232C

Wiring Diagram 1

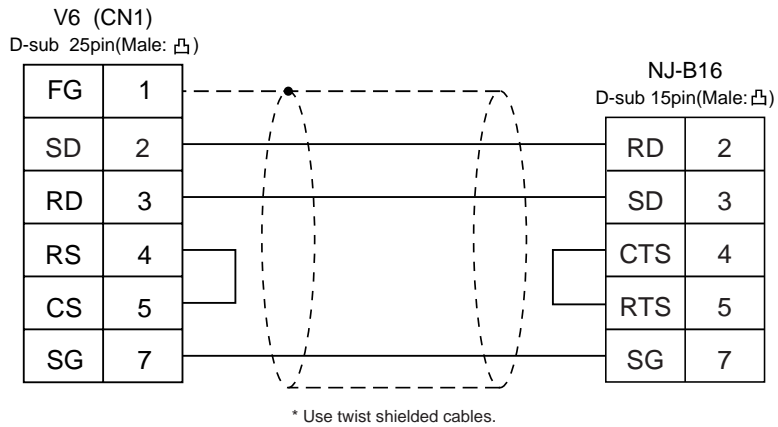

RS-485

Use the cable, "FU-CPUNS" made by Hakko Electronics Co., Ltd., for RS-485 communications.

22 FUJI PLC • 4

(TOYOTA version NJ Computer Link)

Available PLC

Select PLC Type	PLC	Wiring Diagram (refer to P2-64)
FLEX-PC COM	Computer link of FLEX-PC NJ-JM	RS-422 [Wiring Diagram 1]

Connect to the terminal block of the NJ-JM computer link.
For further information, refer to the FUJI's PLC manual.

Communication Setting

The recommended communication parameter setting of both PLC and V6 is as follows:

Item		Setting of PLC	Comm. Parameter of V6
Baud Rate		19200bps	19200bps
Port		0	0
Parity		Even	Even
Transmission Code	Data Length	7	7
	Stop Bit	2	2

Available Memory

Memory	TYPE	Remarks
D (data register)	0	
R (link register)	1	
M (internal relay)	2	WM as word device
K (latch relay)	3	WK as word device
X (input relay)	4	WX as word device
Y (output relay)	5	WY as word device
W (file register)	6	
TN (timer/current value)	7	
CN (counter/current value)	8	
T (timer/contact)	9	
C (counter/contact)	10	
Z (special register)	12	
V (special relay)	13	WV as word device

**Set the memory to the extent of the memory range of each PLC model.
Use TYPE number to assign indirect memory for macro programs.**

Wiring

The following is a diagram to show the wiring of the cable which connects V6 to PLC.

RS-422

Wiring Diagram 1

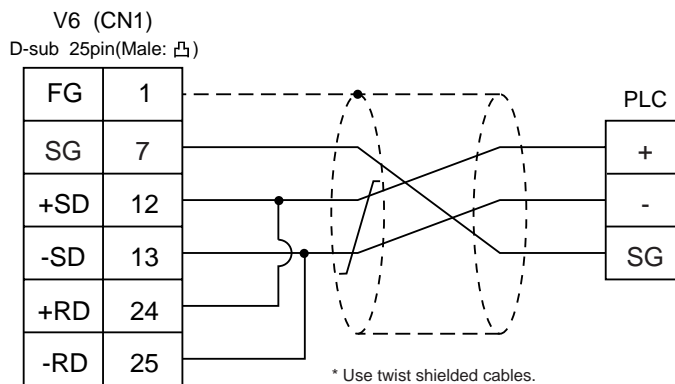

23 Koyo PLC

Available PLC

Select PLC Type	PLC	Link Unit	Wiring Diagram (refer to P2-68, 69)
SU/SG	SU-5/5E/6B/5M/6M	U01-DM	RS-232C [Wiring Diagram 1] RS-422 [Wiring Diagram 3]
	SU-5E/6B	Port 1 on a CPU unit	RS-232C [Wiring Diagram 1] RS-422 [Wiring Diagram 7]
		SU-5M/6M	Port 3 on a CPU unit
	Port 2 on a CPU unit		RS-232C Program transfer cable made by Koyo [S-30JG-E] + Convert connector cable made by Koyo [S-15CNJ]
	SZ-4	Port 2 on a CPU unit	RS-232C Program transfer cable made by Koyo [S-30JG-E] + Convert connector cable made by Koyo [S-15CNJ] + Convert connector made by Koyo [S-15HCNP1]
	SZ-4M	Port 2 on a CPU unit	RS-232C [Wiring Diagram 1] RS-422 [Wiring Diagram 4]
			RS-232C [Wiring Diagram 1] RS-422 [Wiring Diagram 4]
	SG-8	Universal communication port	RS-232C [Wiring Diagram 2] RS-422 [Wiring Diagram 6]
SR-T	SR-6T (TOYOTA version)	U01-DM	RS-232C [Wiring Diagram 1] RS-422 [Wiring Diagram 3]
		G01-DM	RS-232C [Wiring Diagram 1] RS-422 [Wiring Diagram 4]
SR-T (K prt)	SR-1T (TOYOTA version)	Terminal blocks on a CPU unit	RS-422 [Wiring Diagram 5]
SU/SG (K-Sequence)	SU-5E/6B	Port 1 on a CPU unit	RS-232C [Wiring Diagram 1] RS-422 [Wiring Diagram 7]
	SU-5M/6M	Programmer port on a CPU unit	RS-232C Program transfer cable made by Koyo [S-30JG-E]
		Port 3 on a CPU unit	RS-485 [Wiring Diagram 8]
		Port 2 on a CPU unit	RS-232C Program transfer cable made by Koyo [S-30JG-E] + Convert connector cable made by Koyo [S-15CNJ]
	SZ-4	Port 1 on a CPU unit Port 2 on a CPU unit	RS-232C Program transfer cable made by Koyo [S-30JG-E] + Convert connector cable made by Koyo [S-15CNJ]
		Port 1 on a CPU unit	RS-232C Program transfer cable made by Koyo [S-30JG-E] + Convert connector cable made by Koyo [S-15CNJ] + Convert connector made by Koyo [S-15HCNP1]
SZ-4M	Port 2 on a CPU unit	RS-232C Program transfer cable made by Koyo [S-30JG-E] + Convert connector cable made by Koyo [S-15CNJ] + Convert connector made by Koyo [S-15HCNP1]	
		RS-232C Program transfer cable made by Koyo [S-30JG-E] + Convert connector cable made by Koyo [S-15CNJ] + Convert connector made by Koyo [S-15HCNP1]	

Communication Setting

The recommended communication parameter setting of both PLC and V6 is as follows:

Item		Setting of PLC	Comm. Parameter of V6
Baud Rate		19200bps	19200bps
Port		"0" for x10, "1" for x1	1
Parity		Odd	Odd
Transmission Code	Data Length	8	8
	Stop Bit	1	1
Function		Host link system (fixed)	_____
Response Delay Time		0 (fixed)	_____
Time-out		None (fixed)	_____
ASCII/HEX		HEX (fixed)	_____

Available Memory

- SU/SG, SU/SG(K-Sequence)

Memory	TYPE	Remarks
R (data register)	0	
I (input relay)	1	
Q (output relay)	2	
M (internal relay)	3	
S (stage)	4	
GI (global inputs)	5	
GQ (global outputs)	6	
T (timer/contact)	7	
C (counter/contact)	8	

- SR-1T/SR-T(K prt)

Memory	TYPE	Remarks
D (data register)	0	
X (input relay)	1	X/Y common use
Y (output relay)	2	X/Y common use
M (internal relay)	3	
S (stage)	4	
K (keep relay)	5	
L (link relay)	6	
T (timer/contact)	7	
C (counter/contact)	8	

**Set the memory to the extent of the memory range of each PLC model.
Use TYPE number to assign indirect memory for macro programs.**

Switch Setting

○ U-01DM

On-line/off-line switch: on-line

UNIT ADR switch: "0" for x10, "1" for x1

SW4 Dip Switch:

No	Setting	Contents
1	ON	Same as V6 (normally 19200bps)
2	ON	
3	ON	
4	ON	Parity provided
5	OFF	Self-diagnosis
6	OFF	Response delay time 0msec
7	OFF	
8	OFF	

SW5 Dip Switch:

No	Setting	Contents
1	OFF	Master/slave control
2	OFF	Slave
3	OFF	Communication time-out
4	OFF	HEX mode

○ G-01DM

On-line/off-line switch: on-line

Short plug 1: open

Short plug 2 RS-232C: ENABLE
 RS-422: DISENABLE

SW1 Dip Switch:

No	Setting	Contents
1	ON	Unit No. 01
2	OFF	
3	OFF	
4	OFF	
5	OFF	
6	OFF	
7	OFF	
8	OFF	1 : N
9	OFF	Slave

SW2 Dip Switch:

No	Setting	Contents
1	ON	Same as V6 (normally 19200bps)
2	ON	
3	ON	
4	ON	Parity provided
5	OFF	Self-diagnosis
6	OFF	Turn-around delay
7	OFF	Response delay time 0msec
8	OFF	
9	OFF	HEX mode

Wiring

The following is a diagram to show the wiring of the cable which connects V6 to PLC.

RS-232C

Wiring Diagram 1

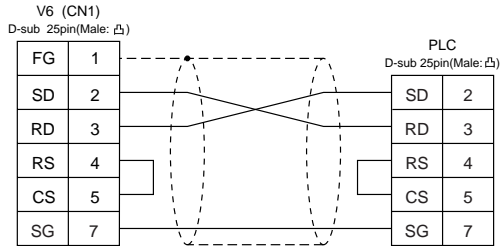

* Use twist shielded cables.

Wiring Diagram 2

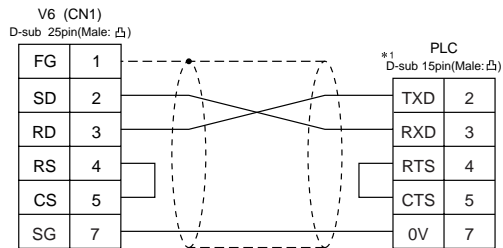

* Use twist shielded cables.

*1 High density D-sub 15pin

RS-422

Wiring Diagram 3

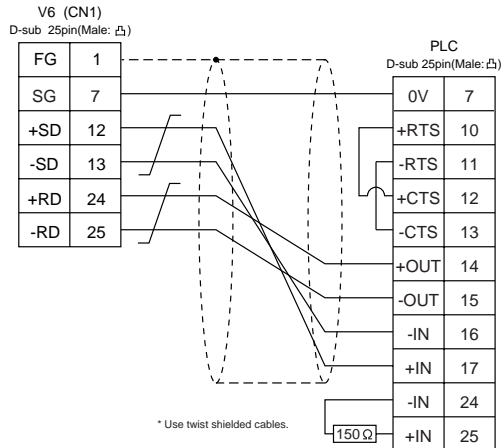

* Use twist shielded cables.

Wiring Diagram 4

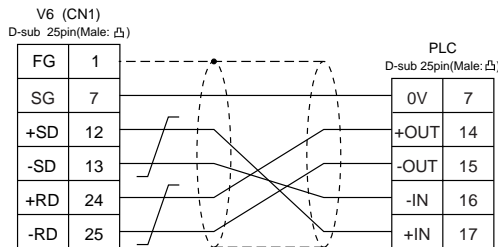

* Use twist shielded cables.

Wiring Diagram 5

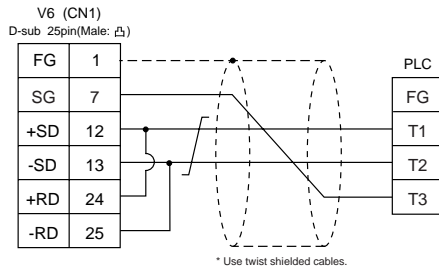

Wiring Diagram 6

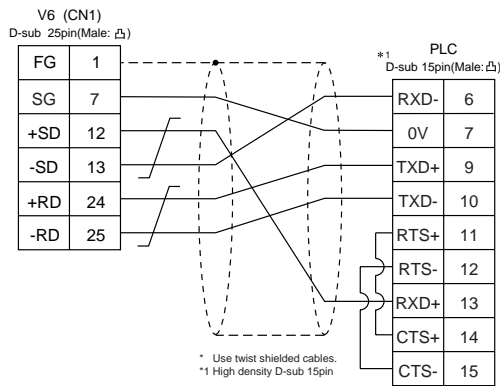

Wiring Diagram 7

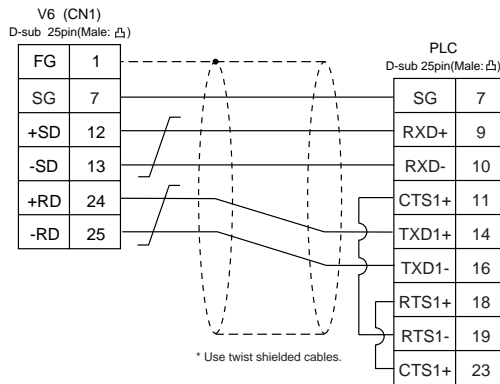

Wiring Diagram 8

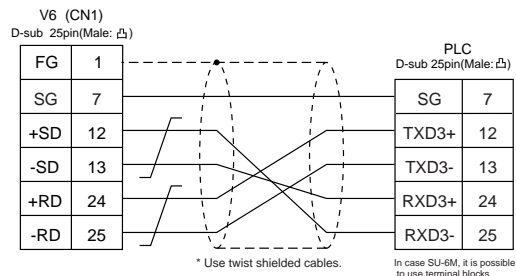

24 Allen-Bradley PLC • 1

(PLC-5 series)

Available PLC

Select PLC Type	PLC	Link Unit	Wiring Diagram (refer to P2-73,74)
PLC-5	PLC-5	1785-KE	RS-232C [Wiring Diagram 1]
		1770-KF2	RS-232C [Wiring Diagram 2] RS-422 [Wiring Diagram 3]

Communication Setting

The recommended communication parameter setting of both PLC and V6 is as follows:

Item	Setting of PLC	Comm. Parameter of V6
Baud Rate	19200bps	19200bps
Port	0	0
Parity	Even	Even
Transmission Control Mode	RS-232C	_____
	RS-422	Not available with 1785-KE
Transmission Code	Data Length	8
	Stop Bit	1
Protocol	Full duplex (fixed)	_____
Error Check	BCC (fixed)	_____
Response	NO (fixed)	_____

Available Memory

Memory	TYPE	Remarks
N (integer)	0	
B (bit)	1	
T.ACC (timer/current value)	2	
T.PRE (timer/set value)	3	
C.ACC (counter/current value)	4	
C.PRE (counter/set value)	5	
I (input)	6	
O (output)	7	
S (status)	8	
T (timer/control)	9	
C (counter/control)	10	
R (control)	11	
R.LEN (control/data length)	12	
R.POS (control/data position)	13	
D (BCD)	14	
A (ASCII)	15	

**Set the memory to the extent of the memory range of each PLC model.
Use TYPE number to assign indirect memory for macro programs.**

Switch Setting

- 1785-KE
SW1 (protocol)

No	Setting	Contents
1	ON	BCC, Even, no
2	OFF	
3	OFF	
4	ON	Duplicate message unacceptable
5	OFF	Handshaking signal ignored
6	ON	Diagnosis execution

SW2 (port)

Specify the port for 1785-KE. (This port should not be duplicated in the network.)

No	Setting	Contents
1	ON	1st digit (octal)
2	ON	
3	ON / OFF	2nd digit (octal)
4	ON / OFF	
5	ON / OFF	
6	ON / OFF	3rd digit (octal)
7	ON / OFF	
8	ON / OFF	

SW3 (network link transmission speed)

Adjust the setting according to the network you are using.

No	Setting	Contents
1	ON	Data highway (57.6k bps)
2	ON	
3	ON	Link transmission speed (19.2k bps)
4	ON	
5	ON	
6	ON	Local/remote selection

SW4 (spare)

No	Setting	Contents
1	OFF	Normally OFF (for expansion)
2	OFF	
3	OFF	
4	OFF	

○ 1770-KF2

SW1 (protocol)

No	Setting	Contents
1	ON	Protocol
2	OFF	Protocol
3	ON	Duplicated message unacceptable
4	OFF	Handshaking signal ignored
5	OFF	Protocol

SW2, SW3, SW4 (port)

Specify the port for 1770-KF2. (This port should not be duplicated in the network.)

SW5 (network link transmission speed)

Adjust the setting according to the network you are using.

Switch Setting		Contents
1	2	
ON	ON	57.6k bps

SW6 (asynchronous link transmission speed)
Set the same speed as V6.

No	Setting	Contents
1	OFF	9600bps
2	ON	
3	ON	
4	ON	Diagnosis execution

SW7 (network link selection)

Switch Setting		Contents
1	2	
ON	OFF	Peer transmission link

SW8 (RS-232C/RS-422 selection)

Switch Setting		Contents
1	2	
OFF	ON	RS232C
ON	OFF	RS422

Wiring

The following is a diagram to show the wiring of the cable which connects V6 to PLC.

RS-232C

Wiring Diagram 1

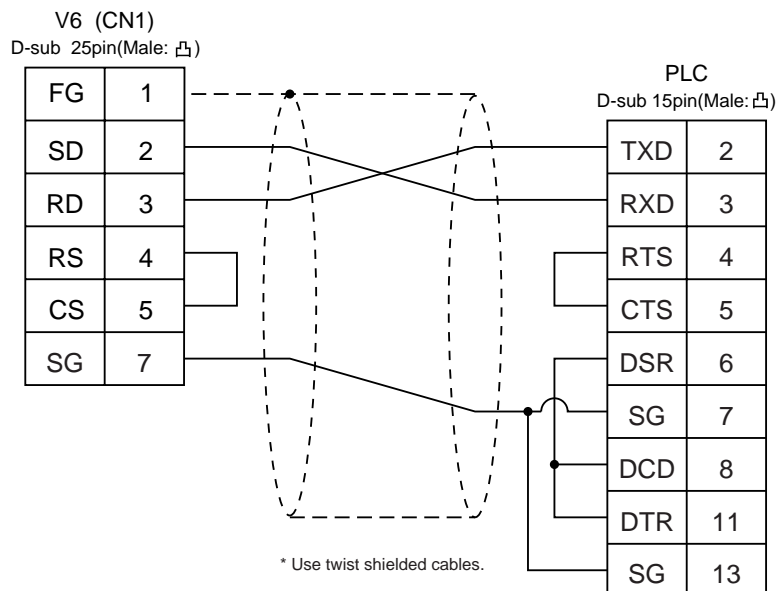

Wiring Diagram 2

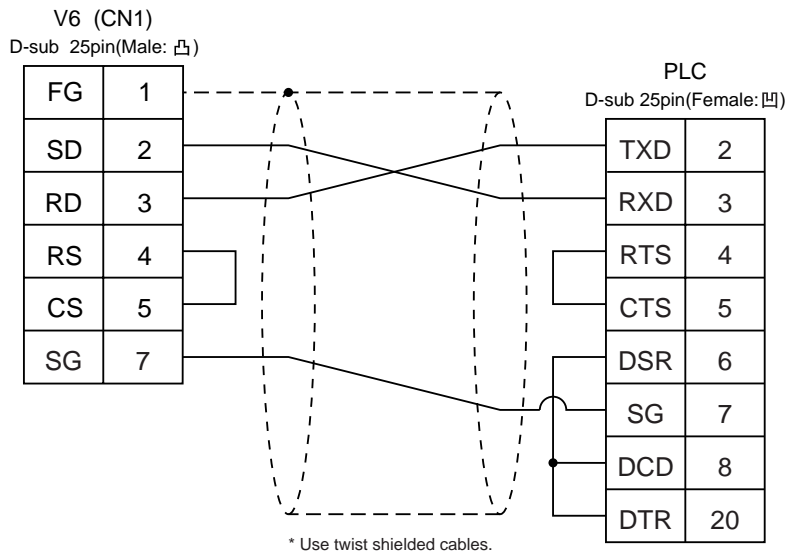

RS-422

Wiring Diagram 3

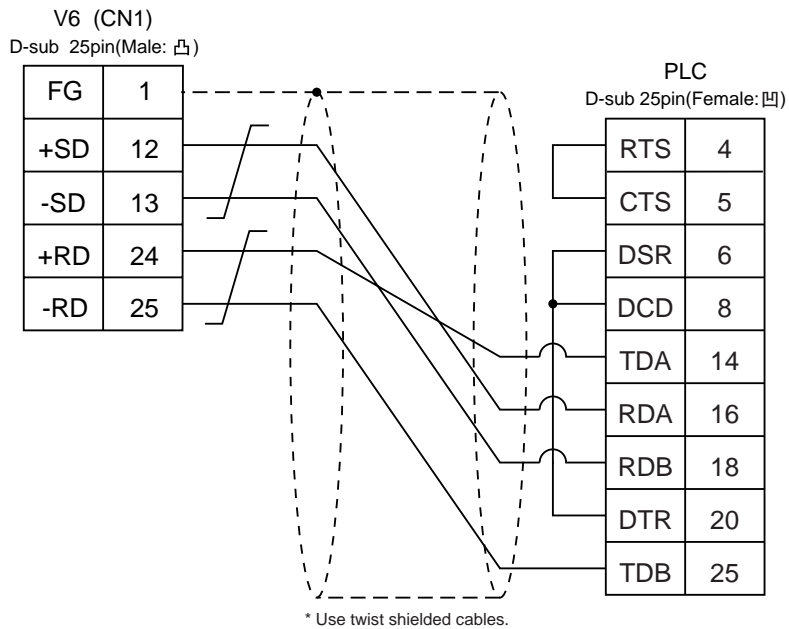

25 Allen-Bradley PLC • 2

(SLC500 series, Micro Logix 1000)

Available PLC

Select PLC Type	PLC	Link Unit	Wiring Diagram (refer to P2-77, 78)
SLC500	SLC 5/03 or later models	CPU (Processor module) RS-232C channel	RS-232C [Wiring Diagram 1]
		1747-KE	RS-232C [Wiring Diagram 2] RS-422 [Wiring Diagram 4]
Micro Logix 1000	Micro Logix 1000	Port on a CPU unit	*RS-232C program transfer cable made by A-B +RS-232C [Wiring Diagram 3]

* When using RS-232C program transfer cable made by Allen-Bradley, connect the cable of [Wiring Diagram 3] to the D-sub 9 pins side of the program transfer cable to communicate with V6.

Communication Setting

The recommended communication parameter setting of both PLC and V6 is as follows:

◆SLC500 series

Item	Setting of PLC	Comm. Parameter of V6
Baud Rate	19200bps	19200bps
Port	0	0
Parity	Even	Even
Transmission Control Mode	RS-232C	_____
	RS-422	not supported on Channel 0
Transmission Code	Data Length	8
	Stop Bit	1
Protocol	Full duplex (fixed)	_____
Error Check	BCC (fixed)	_____
Response	NO (fixed)	_____

◆Micro Logix 1000

Item	Setting of PLC	Comm. Parameter of V6
Baud Rate	9600bps	9600bps
Port	0	0
Parity	none (fixed)	none
Transmission Code	Data Length	8 (fixed)
	Stop Bit	1 (fixed)
Error Check	CRC (fixed)	_____

Available Memory

Memory	TYPE	Remarks
N (integer)	0	
B (bit)	1	
T.ACC (timer/current value)	2	
T.PRE (timer/set value)	3	
C.ACC (counter/current value)	4	
C.PRE (counter/set value)	5	
I (input)	6	
O (output)	7	
S (status)	8	
T (timer/control)	9	
C (counter/control)	10	
R (control)	11	
R.LEN (control/data length)	12	
R.POS (control/data position)	13	
D (BCD)	14	
A (ASCII)	15	
F (Float)	16	
ST (String)	17	

Set the memory to the extent of the memory range of each PLC model.

Use TYPE number to assign indirect memory for macro programs.

Transmission Parameter Setting

- CPU Port Channel 0

Set up the parameters for CPU port channel 0, using the software specifically designed for this purpose.

Baud Rate : 19200
 Duplicate Detect : ON
 ACK Timeout(x20 ms) : 20
 Control Line : NO HANDSHAKING
 Parity : EVEN
 Error Detect : BCC
 NAK Retries : 3
 ENQ Retries : 3
 Embedded Responses : AUTO-DETECT

○ 1747-KE

Set up the parameters for 1747-KE, using the software specifically designed for this purpose.

DF1 Port Setup Menu

Baudrate : 19200
 Bits Per Character : 8
 Parity : Even
 Stop Bits : 1

DF1 Full-Duplex Setup Parameters

Duplicate Packet Detection : Enabled
 Checksum : BCC
 Constant Carrier Detect : Disabled
 Message Timeout : 400
 Hardware Handshaking : Disabled
 Embedded Response Detect : Auto Detect
 ACK Timeout(×5ms) : 90
 ENQuery Retries : 3
 NAK Received Retries : 3

Wiring

The following is a diagram to show the wiring of the cable which connects V6 to PLC.

RS-232C

Wiring Diagram 1

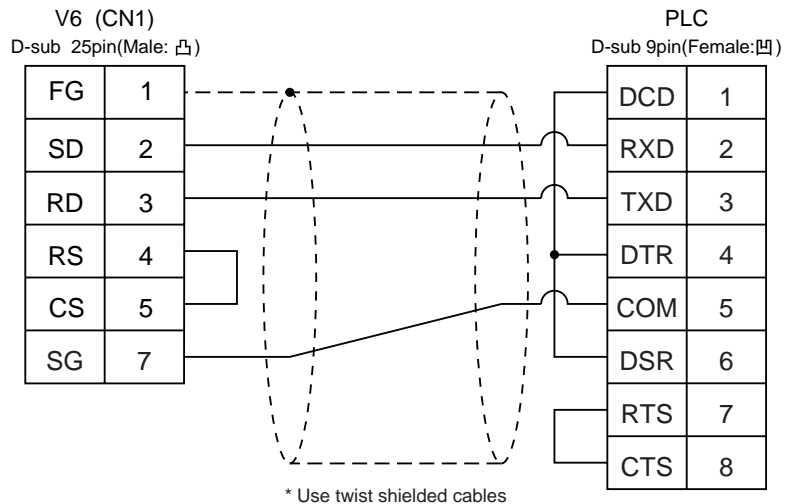

Wiring Diagram 2

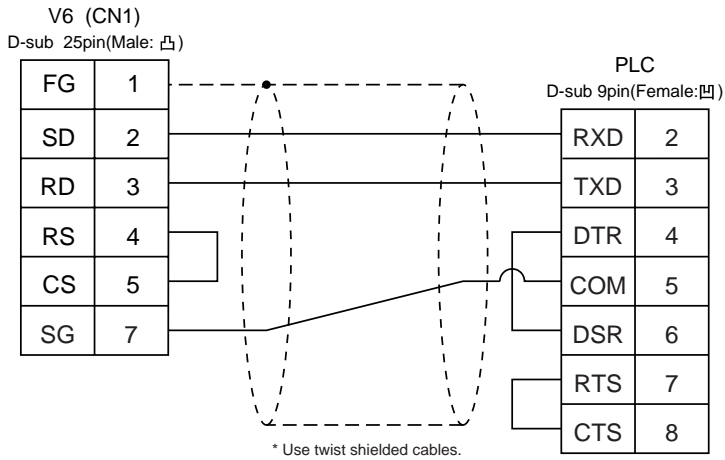

Wiring Diagram 3

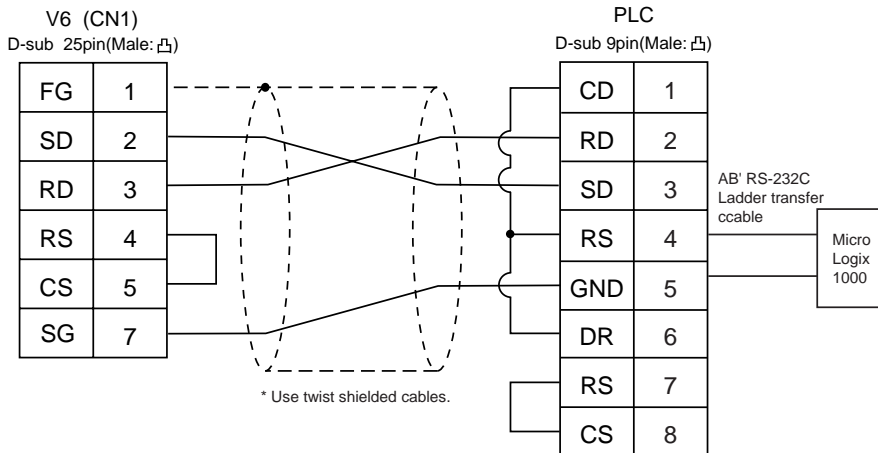

RS-422

Wiring Diagram 4

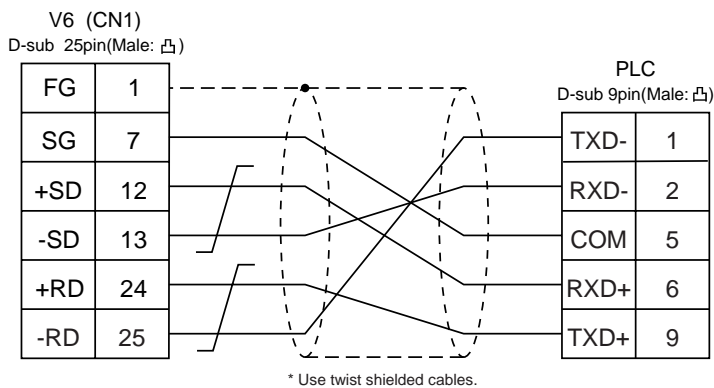

26 GE Fanuc PLC • 1

(90 series)

Available PLC

Select PLC Type	PLC	Link Unit	Wiring Diagram (refer to P2-80)
90 Series	Series 90-30	Programmable co-processor (PCM)	RS-232C [Wiring Diagram 1] RS-485 [Wiring Diagram 2]

Communication Setting

The recommended communication parameter setting of both PLC and V6 is as follows:

Item		Setting of PLC	Comm. Parameter of V6
Baud Rate		19200bps	19200bps
Port		01 ("0" for x10, "1" for x1)	1
Parity		Odd	Odd
Transmission Code	Data Length	8	8
	Stop Bit	1	1
Function		Host link system (fixed)	_____
Response Delay Time		0 (fixed)	_____
Time-out		None (fixed)	_____
ASCII/HEX		HEX (fixed)	_____

Available Memory

Memory	TYPE	Remarks
R (data register)	0	
I (input)	1	
Q (output)	2	

Set the memory to the extent of the memory range of each PLC model.
Use TYPE number to assign indirect memory for macro programs.

Wiring

The following is a diagram to show the wiring of the cable which connects V6 to PLC.

RS-232C

Wiring Diagram 1

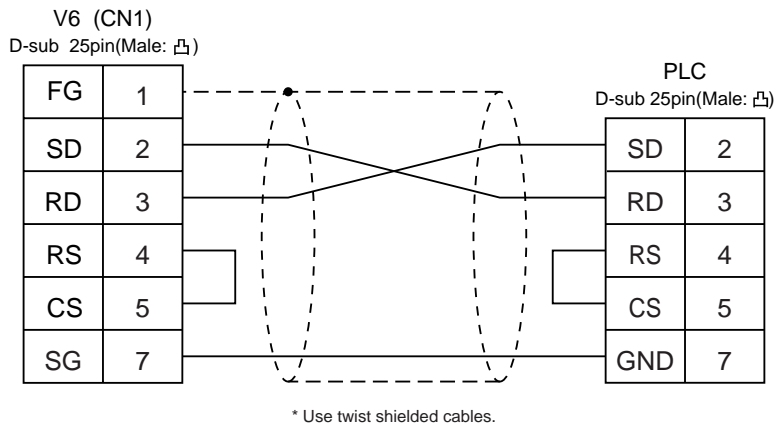

RS-485

Wiring Diagram 2

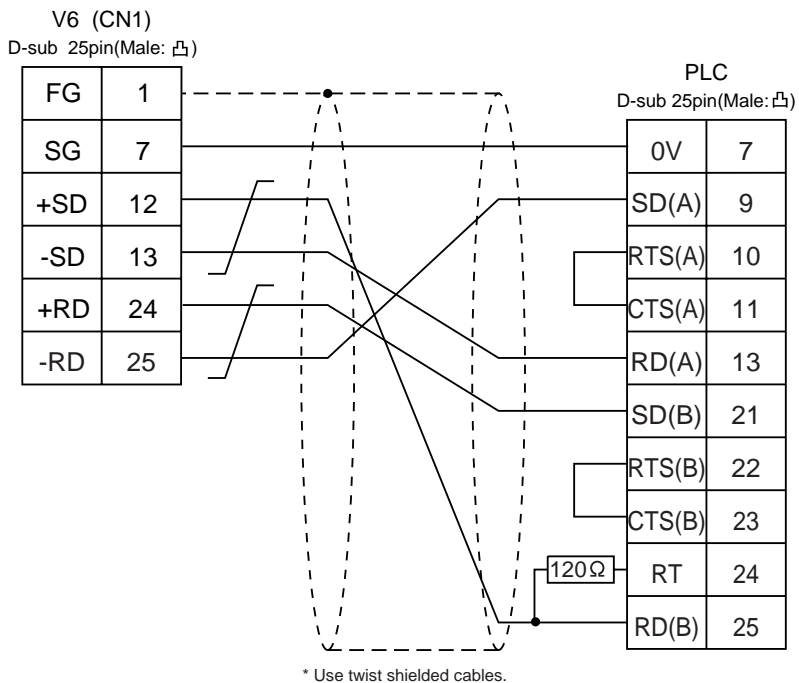

27 GE Fanuc PLC • 2

(90 series SNP-X)

Available PLC

Select PLC Type	PLC	Wiring Diagram (refer to P2-82)
90 Series (SNP-X)	Series 90 micro (CPU port) Series 90-30 (CPU port)	RS-485 [Wiring Diagram 1]

Communication Setting

The recommended communication parameter setting of both PLC and V6 is as follows:

Item	Setting of PLC	Comm. Parameter of V6
Baud Rate	19200bps	19200bps
Parity	Odd	Odd
Transmission Code	Data Length	8
	Stop Bit	1
Function	SNP-X (fixed)	_____

Available Memory

Memory	TYPE	Remarks
R (data register)	0	
I (input)	1	
Q (output)	2	
M (internal relay)	3	
G (global relay)	4	
AI (analog input)	5	
AQ (analog output)	6	
T (temporary memory relay)	7	
S (system status)	8	Read only
SA (system status)	9	
SB (system status)	10	
SC (system status)	11	

**Set the memory to the extent of the memory range of each PLC model.
Use TYPE number to assign indirect memory for macro programs.**

Wiring

The following is a diagram to show the wiring of the cable which connects V6 to PLC.

RS-485

Wiring Diagram 1

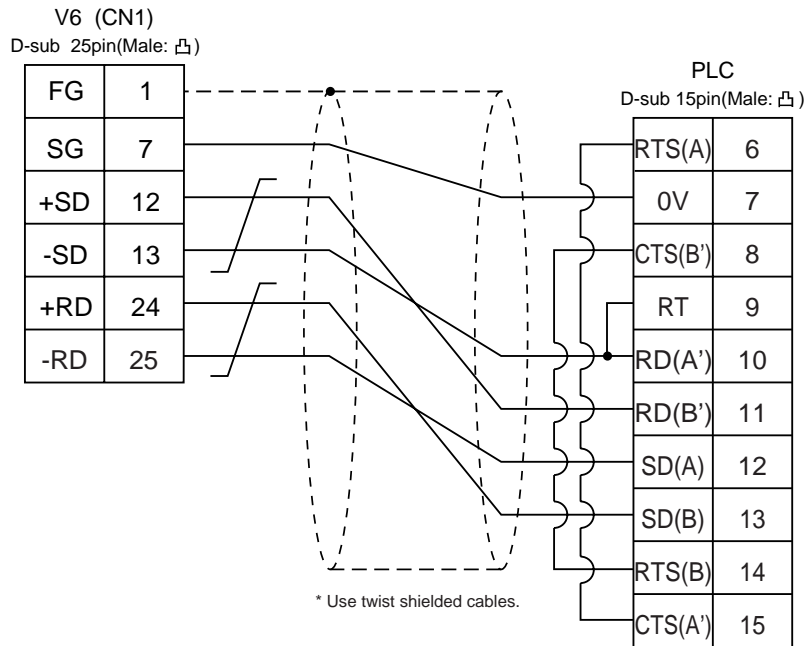

28 TOSHIBA PLC

(T series)

Available PLC

Select PLC Type	PLC	Wiring Diagram (refer to P2-84)
T Series	T series	RS-422 [Wiring Diagram 1]

Communication Setting

The recommended communication parameter setting of both PLC and V6 is as follows.
For further information, refer to the TOSHIBA's PLC manual.

Item	Setting of PLC	Comm. Parameter of V6
Baud Rate	19200bps	19200bps
Port	01	1
Parity	Odd	Odd
Transmission Code	Data Length	8
	Stop Bit	1

PLC Transmission Parameter Setting

For specifying parameters in the T series PLC, use a T-series programmer and enter the following data in the system information "7. COMPUTER LINK".

Station No. 1
 Baud rate 19200 BPS
 Parity Odd
 Data bit 8 bit
 Stop bit 1 bit

Available Memory

Memory	TYPE	Remarks
D (data register)	0	
X (input register)	1	XW as word device
Y (output register)	2	YW as word device
R (auxiliary relay)	5	RW as word device
L (link relay)	6	LW as word device
W (link register)	7	
F (file register)	8	
TN (timer/current value)	9	Read only
CN (counter/current value)	10	Read only
TS (timer/contact)	11	Read only
CS (counter/contact)	12	Read only

Set the memory to the extent of the memory range of each PLC model.
Use TYPE number to assign indirect memory for macro programs.

Wiring

The following is a diagram to show the wiring of the cable which connects V6 to PLC.

RS-422

Wiring Diagram 1

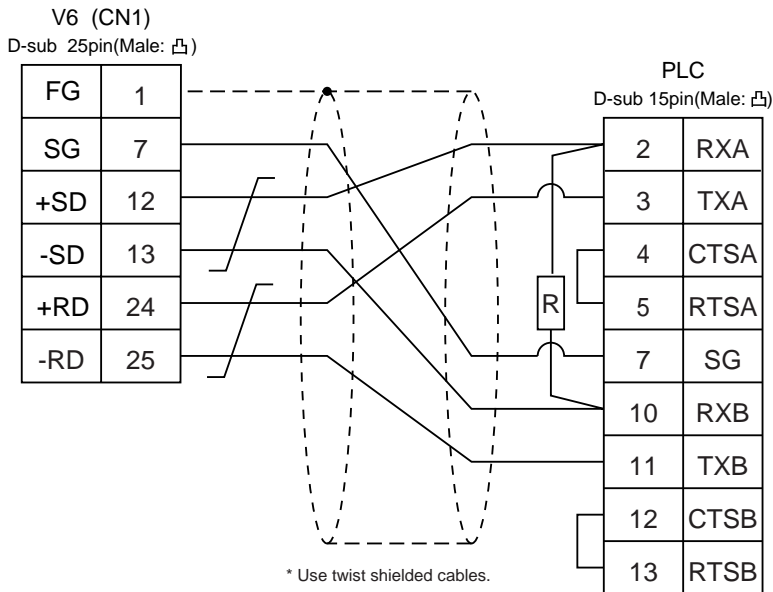

29 TOSHIBA MACHINE PLC

(TC200)

Available PLC

Select PLC Type	PLC	Link Unit	Wiring Diagram (refer to P2-86)
TC200	TC200	Port on a CPU unit	RS-232C [Wiring Diagram 1]
		TCCMW TCCMO	

Communication Setting

The recommended communication parameter setting of both PLC and V6 is as follows.

Item	Setting of PLC	Comm. Parameter of V6
Baud Rate	9600bps	9600bps
Port	1	1

Available Memory

Memory	TYPE	Remarks
D (register 1)	0	
B (register 2)	1	
X (input relay)	2	XW as word device
Y (output relay)	5	YW as word device
R (temporary storage)	6	RW as word device
G (extension temporary storage 1)	7	GW as word device
H (extension temporary storage 2)	8	HW as word device
L (latch relay)	9	LW as word device
S (shift register)	10	SW as word device
E (edge relay)	11	EW as word device
P (timer counter current value)	12	
V (timer counter set value)	13	
T (timer)	14	TW as word device
C (counter)	15	CW as word device
A (special auxiliary relay)	16	AW as word device

Set the memory to the extent of the memory range of each PLC model.

Use TYPE number to assign indirect memory for macro programs.

Wiring

The following is a diagram to show the wiring of the cable which connects V6 to PLC.

RS-232C

Wiring Diagram 1

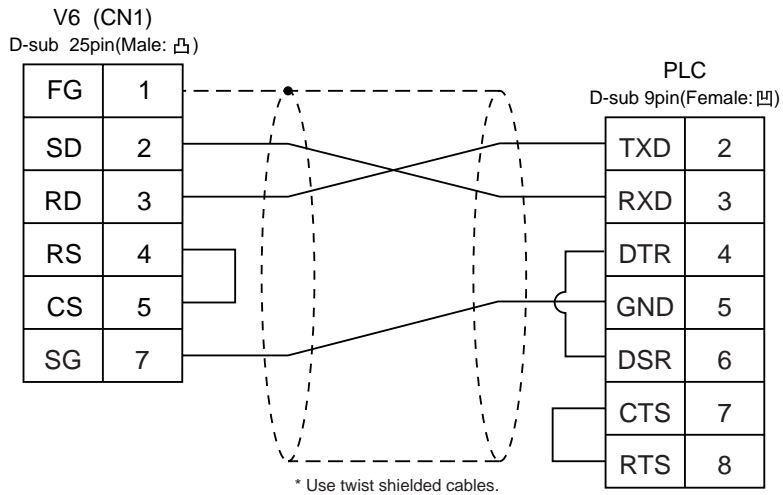

30 SIEMENS PLC • 1

(S5-90, S5-95U, S5-100U)

Available PLC

A similar program as RK512 is required.

Select PLC Type	PLC	Link Unit	Wiring Diagram(refer to P2-88)
S5 (S5 V4)	S5-90U S5-95U S5-100U	CP-521SI (3964R Transmission Protocol)	RS-232C [Wiring Diagram 1]
	S5-95U	Second serial interface (3964R Transmission Protocol)	*[6ES5 734-1BD20] cable made by SIEMENS + RS-232C [Wiring Diagram 2]

* When using [6ES5 734-1BD20] cable made by SIEMENS, connect the cable of [Wiring Diagram 2] to the D-sub 25 pins side of [6ES5 734-1BD20] to communicate with V6.

Communication Setting

The recommended communication parameter setting of both PLC and V6 is as follows:

Item		Setting of PLC	Comm. Parameter of V6
Baud Rate		9600bps	9600bps
Parity		Even parity	Even
Transmission Code	Data Length	8	8
	Stop Bit	1	1
Busy Signal		NO (fixed)	_____
Hand Shake		OFF(fixed)	_____

Available Memory

Memory	TYPE	Remarks
DB (data register)	0	Use memories more than DB3.
I (input relay)	1	IW as word device Read only
Q (output relay)	2	QW as word device Read only
F (internal relay)	3	FW as word device Read only
T (timer/current value)	4	Read only
C (counter/current value)	5	Read only
AS (absolute address)	6	

◇ **The assigned memory is indicated while editing the screen as illustrated:**

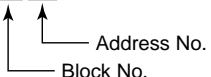
<E.g.> DB003000

- ◇ Set the memory to the extent of the memory range of each PLC model.
Use TYPE number to assign indirect memory for macro programs.

- ◇ Notes on converting the data file of V4 (or GD-80) into the V6 data file
When converting the data file of V4 (or GD-80) into the V6 data file, the PLC type is automatically selected as "SIEMENS S5 V4."
In V4 (or GD-80), the order of bytes in I (input relay), Q (output relay) and F (internal relay) is reversed.

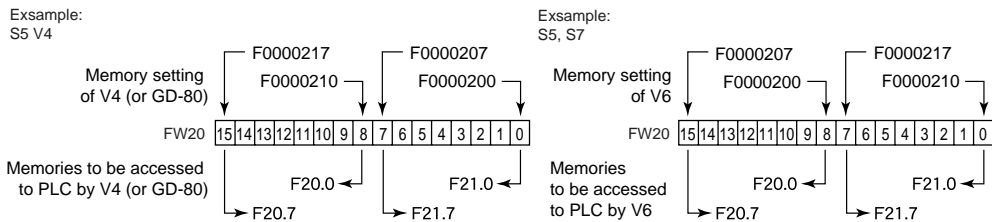

Wiring

The following is a diagram to show the wiring of the cable which connects V6 to PLC.

RS-232C

Wiring Diagram 1

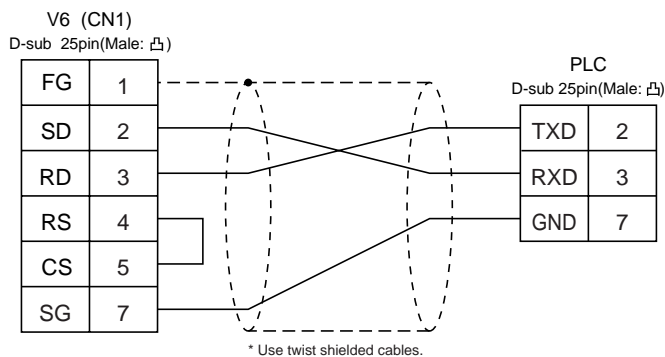

Wiring Diagram 2

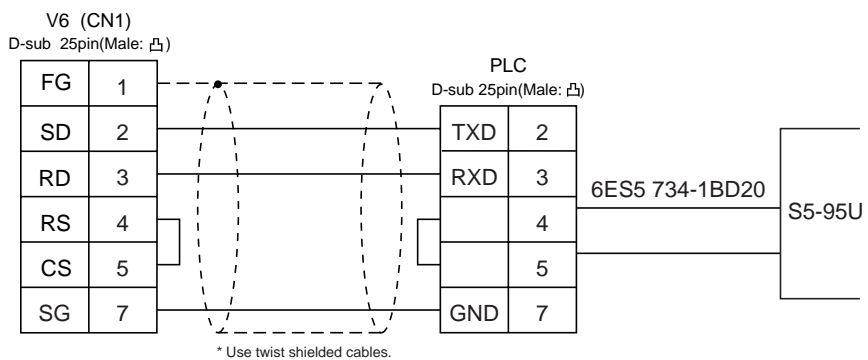

31 SIEMENS PLC • 2

(S5-115U/135U/155U, S7-300, S7-400)

Available PLC

Select PLC Type	PLC	Link Unit	Wiring Diagram (refer to P2-90)
S5 (S5 V4)	S5-115U	CP-524(3964R/RK512)	RS-232C [Wiring Diagram 1]
	S5-135U	CP-544(3964R/RK512)	RS-422 [Wiring Diagram 3]
	S5-155U		
S7	S7-300	CP-341(3964R/RK512)	RS-232C [Wiring Diagram 2]
	S7-400	CP-441(3964R/RK512)	RS-422 [Wiring Diagram 3]

Communication Setting

The recommended communication parameter setting of both PLC and V6 is as follows:

Item	Setting of PLC	Comm. Parameter of V6
Baud Rate	9600bps	9600bps
Parity	—————	Even (fixed)
Transmission Code	Data Length	8 (fixed)
	Stop Bit	1 (fixed)

Available Memory

Memory	TYPE	Remarks
DB (data register)	0	Use memories, more than DB1 for S7, more than DB3 for S5.
I (input relay)	1	IW as word device Read only
Q (output relay)	2	QW as word device Read only
F (internal relay)	3	FW as word device Read only only in S5 series
M (internal relay)	3	MW as word device Read only only in S7 series
T (timer/current value)	4	Read only
C (counter/current value)	5	Read only
AS (absolute address)	6	Can not be used in S7 series.

◇ **The assigned memory is indicated while editing the screen as illustrated:**

◇ **Set the memory to the extent of the memory range of each PLC model.**

Use TYPE number to assign indirect memory for macro programs.

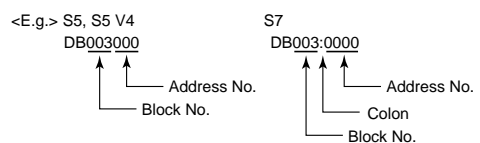

◆ **Notes on converting the data file of V4 (or GD-80) into the V6 data file**

When converting the data file of V4 (or GD-80) into the V6 data file, the PLC type is automatically selected as "SIEMENS S5 V4."

In V4 (or GD-80), the order of bytes in I (input relay), Q (output relay) and F (internal relay) is reversed.

Exsample:
S5 V4

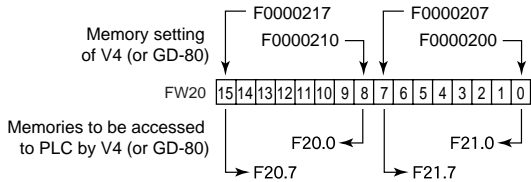

Exsample:
S5, S7

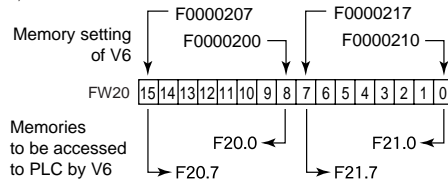

Wiring

The following is a diagram to show the wiring of the cable which connects V6 to PLC.

RS-232C

Wiring Diagram 1

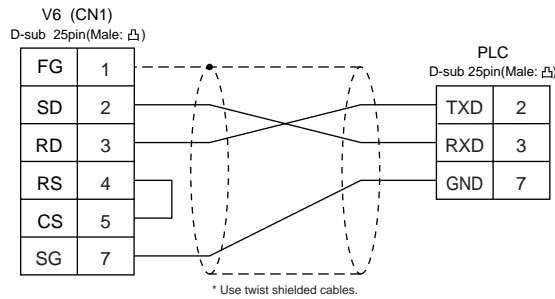

Wiring Diagram 2

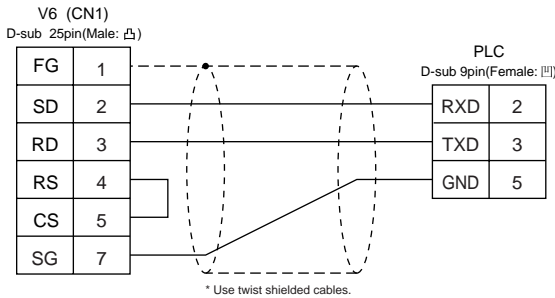

RS-422

Wiring Diagram 3

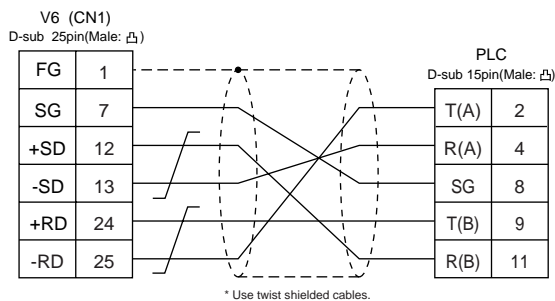

32 SIEMENS PLC • 3

(S5 PG port)

Connection

Connect to the S5 series PG port.

The communication parameter setting of V6 is done automatically.

Available PLC

Select PLC Type	PLC	Link Unit	Wiring Diagram (refer to P2-92)
S5 PG port	S5 series	Programming port on a CPU unit	*[6ES5 734-1BD20] cable made by SIEMENS + RS-232C [Wiring Diagram 1]

* When using [6ES5 734-1BD20] cable made by SIEMENS, connect the cable of [Wiring Diagram 1] to the D-sub 25 pins side of [6ES5 734-1BD20] to communicate with V6.

Available Memory

Memory	TYPE	Remarks
DB (data register)	0	Use memories more than DB3.
I (input relay)	1	IW as word device
Q (output relay)	2	QW as word device
F (internal relay)	3	FW as word device
T (timer/current value)	4	
C (counter/current value)	5	
AS (absolute address)	6	

◇ The assigned memory is indicated while editing the screen as illustrated:

<E.g.> DB003000

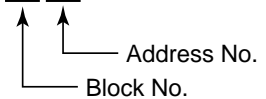

◇ Set the memory to the extent of the memory range of each PLC model.
Use TYPE number to assign indirect memory for macro programs.

Wiring

The following is a diagram to show the wiring of the cable which connects V6 to PLC.

RS-232C

Wiring Diagram 1

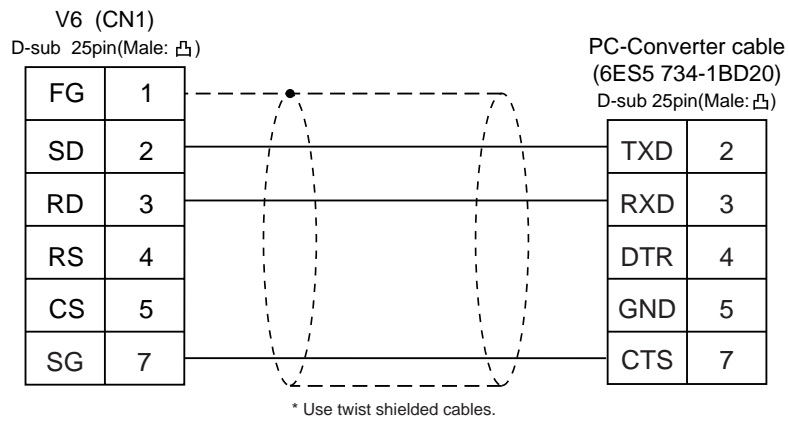

33 SIEMENS PLC • 4

(S7-200 PPI)

Available PLC

Select PLC Type	PLC	Wiring Diagram (refer to P2-94)
S7-200 PPI	S7-200 series	RS-422 [Wiring Diagram 1]

Communication Setting

The recommended communication parameter setting of both PLC and V6 is as follows:

Item	Setting of PLC	Comm. Parameter of V6
Baud Rate	9600bps	9600bps
Port	2	2
Parity	Even (fixed)	_____

Available Memory

Memory	TYPE	Remarks
V (data memory)	0	VW as word device
I (input)	1	IW as word device Possible to write only to the area which is not used
Q (output)	2	
M (bit memory)	3	
T (timer/current value)	4	
C (counter/current value)	5	
TB (timer/contact)	6	Read only
CD (counter/contact)	7	Read only
HC (high speed counter/contact)	8	Possible to use double words
AIW (analog input)	9	
AQW(analog output)	10	
SM (special memory/special relay)	11	SMW as word device
S (stage)	12	SW as word device

Set the memory to the extent of the memory range of each PLC model.
Use TYPE number to assign indirect memory for macro programs.

Wiring

The following is a diagram to show the wiring of the cable which connects V6 to PLC.

RS-422

Wiring Diagram 1

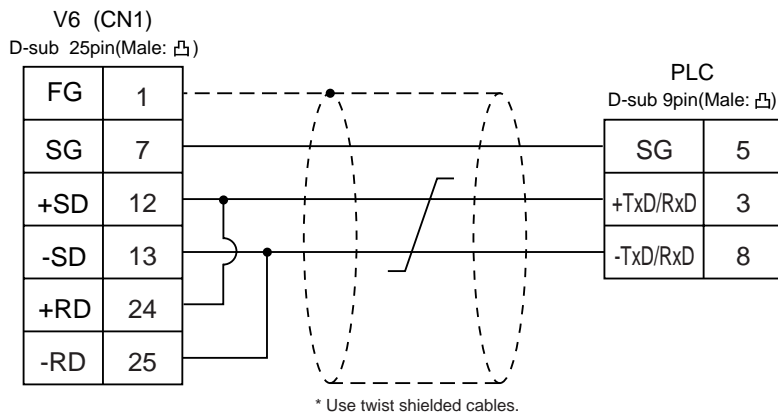

Setting of Terminal Resistance

Set the dip switch 7,8 of V6 series to OFF.

Connect terminal resistance to the V6 serial connector (CN1) as follows.

If terminal resistance is not connected, the communication error may occur.

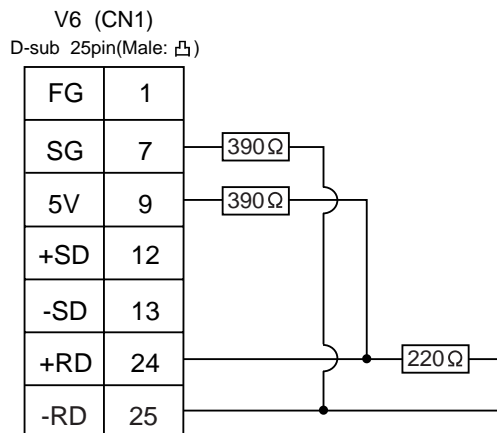

34 SIEMENS PLC • 5

(TI545, 555)

Available PLC

Select PLC Type	PLC	Wiring Diagram (refer to P2-96)
TI500/505 (TI500/505 V4)	TI545/555 CPU port (built-in)	RS-232C [Wiring Diagram 1] RS-422 [Wiring Diagram 2]

Communication Setting

Connect the cable to the CPU port (RS-232C built-in port) for TI545/555.

The recommended communication parameter setting of both PLC and V6 is as follows:

Item	Setting of PLC	Comm. Parameter of V6
Baud Rate	19200bps	19200bps
Parity	_____	None (fixed)
Transmission Code	Data Length	8 (fixed)
	Stop Bit	1 (fixed)

Available Memory

Memory	TYPE	Remarks
V (variable memory)	0	
WX (word input)	1	
WY (word output)	2	
X (discrete input)	3	
Y (discrete output)	4	
CR (control relay)	5	
TCP (timer counter/set value)	6	
TCC (timer counter/current value)	7	
DCP (drum count/set value)	8	*1
DCC (drum count/current value)	9	Read only
DSP (drum step/set value)	10	
DSC (drum step/current value)	11	
K (fixed memory)	12	
STW (system state)	13	

*1 In case of using DCP (drum count/set value), set the drum step No.1 to 16.

The assigned memory is indicated while editing the screen as illustrated:

<E.g.> DCP30000 : 1

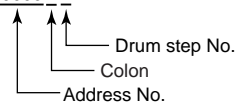

**Set the memory to the extent of the memory range of each PLC model.
Use TYPE number to assign indirect memory for macro programs.**

◇ **Notes on converting the data file of V4 (or GD-80) into the V6 data file**

When converting the data file of V4 (or GD-80) into the V6 data file, the PLC type is automatically selected as "TI500/505 V4."

In V4 (or GD-80), the order of words is reversed when the double words.

In V4 or GD-80

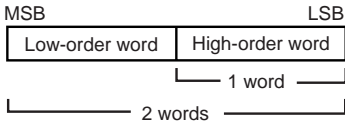

In V6

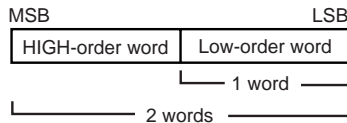

Wiring

The following is a diagram to show the wiring of the cable which connects V6 to PLC.

RS-232C

Wiring Diagram 1

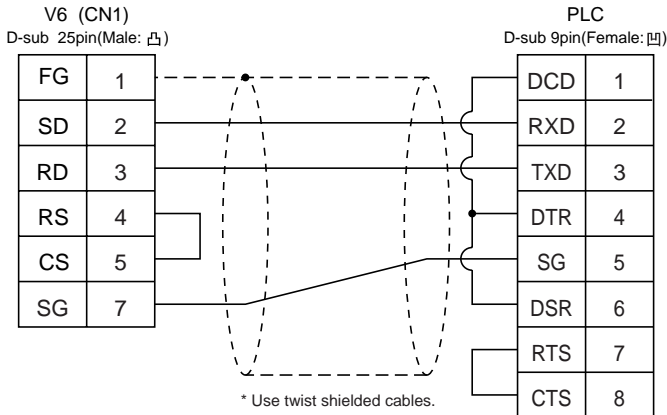

RS-422

Wiring Diagram 2

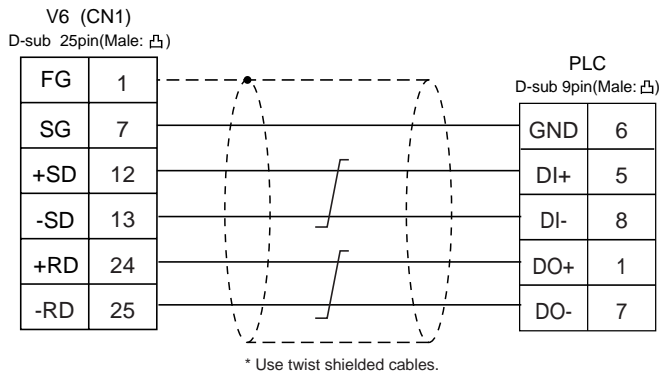

35 SIEMENS PLC • 6

(S7-300/400MPI, S7-300MPI ADP)

Available PLC

Select PLC Type	CPU	Adapter	Wiring Diagram (refer to P2-98)
S7-300/400MPI	S7-300/400 series	MPI port	RS-422 [Wiring Diagram 2]
S7-300MPI (HMI ADP)	S7-300/400 series (MPI port)	SIEMENS HMI Adapter 6ES7 972 0CA11-0XA0	RS-232C [Wiring Diagram 1]
S7-300MPI (PC ADP)		SIEMENS PC Adapter 6ES7 9720CA23-0XA0	
S7-300MPI (Helmholz SSW7 ADP)		Helmholz SSW7 Adapter	

Communication Setting

The recommended communication parameter setting of both PLC and V6 is as follows:

- S7-300/400 MPI

Item	Setting of PLC	Comm. Parameter of V6
Baud Rate	19200bps	19200bps (fixed)
Parity	————	Even (fixed)
Transmission Code	Data Length	8 (fixed)
	Stop Bit	1 (fixed)
Local No.(station no. of PLC)	2	2

- S7-300MPI (HMI ADP / PC ADP / Helmholz SSW7 ADP)

Item	Setting of PLC	Comm. Parameter of V6	
		HMI ADP	PC ADP Helmholz ADP
Baud Rate	38400bps	38400bps (fixed)	38400bps
Parity	————	None (fixed)	
Transmission Code	Data Length	8 (fixed)	
	Stop Bit	1 (fixed)	
Local No.(station no. of PLC)	2	2	

Set the [MPI SETTING] in the [Comm. Parameter] in V-SFTE.

ITEM	MPI SETTING
Highest MPI Address	15/31/63/126
Source No (station no.of V6)	0

Highest MPI Address : Specify the highest number on the network.

Source No :

Station number of V6. Make sure that this number is unique. Set difference number for [Source No.] and [Local No.], and make sure that [Source No.] ≤ [Node Cnt.]

<E.g.> PLC is "13" and V6 is "20", select "31".

Available Memory

Memory	TYPE	Remarks
DB (data register)	0	Use memories more than DB1.
I (input relay)	1	IW as word device
Q (output relay)	2	QW as word device
M (Merker Word)	3	MW as word device
T (timer/current value)	4	
C (counter/current value)	5	

◇ **The assigned memory is indicated while editing the screen as illustrated:**

<E.g.> DB0001: 0000

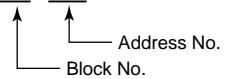

◇ **Set the memory to the extent of the memory range of each PLC model. Use TYPE number to assign indirect memory for macro programs.**

Wiring

The following is a diagram to show the wiring of the cable which connects V6 to PLC.

RS-232C

Wiring Diagram 1

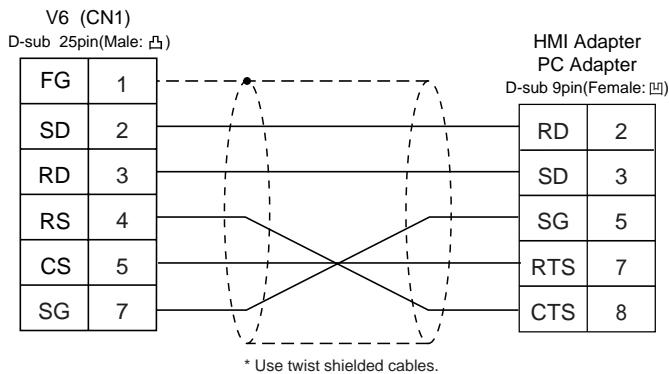

RS-422

Wiring Diagram 2

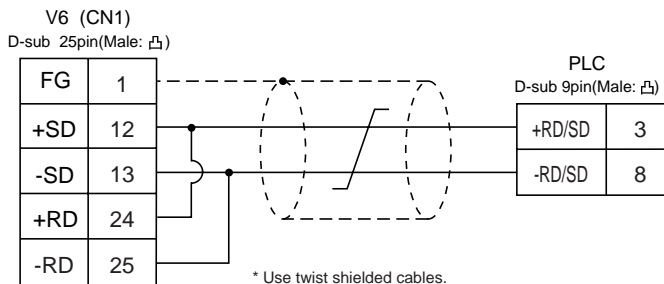

36 Shinko PLC

Available PLC

Select PLC Type	PLC	Link Unit	Wiring Diagram (refer to P2-100)
SELMART	SELMART-100 or later series	Version O1M2-UCI-6X	RS-232C [Wiring Diagram 1]

Communication Setting

The recommended communication parameter setting of both PLC and V6 is as follows:

Item		Setting of PLC	Comm. Parameter of V6
Baud Rate		19200bps	19200bps
Parity		Even	Even
Transmission Code	Data Length	7 (ASCII)	7
	Stop Bit	1	1
Sum Check		Provided (fixed)	_____

Available Memory

Memory	TYPE	Remarks
D (data register)	0	

Only D register is available for this PLC model.

No other devices can be used although they are available to be set in the panel editor.

Set the memory to the extent of the memory range of each PLC model.

Use TYPE number to assign indirect memory for macro programs.

Wiring

The following is a diagram to show the wiring of the cable which connects V6 to PLC.

RS-232C

Wiring Diagram 1

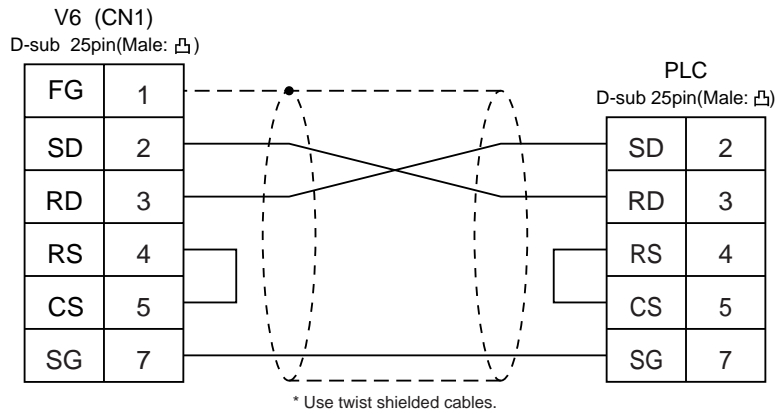

37 SAMSUNG PLC

(SPC series)

Available PLC

Select PLC Type	PLC	Wiring Diagram (refer to P2-102)
SPC Series	SPC series	RS-232C [Wiring Diagram 1] RS-422/485 [Wiring Diagram 2]

Communication Setting

The recommended communication parameter setting of both PLC and V6 is as follows:

Item	Setting of PLC	Comm. Parameter of V6
Baud Rate	9600bps	9600bps
Parity	None	None
Stop Bit	1	1
Terminal Resistor	ON for RS-485	_____

Available Memory

Memory	TYPE	Remarks
R (input/output)	0	
L (link relay)	1	
M (internal relay)	2	
K (keep relay)	3	
F (special relay)	4	
W (data register)	5	

Set the memory to the extent of the memory range of each PLC model.

Use TYPE number to assign indirect memory for macro programs.

Wiring

The following is a diagram to show the wiring of the cable which connects V6 to PLC.

RS-232C

Wiring Diagram 1

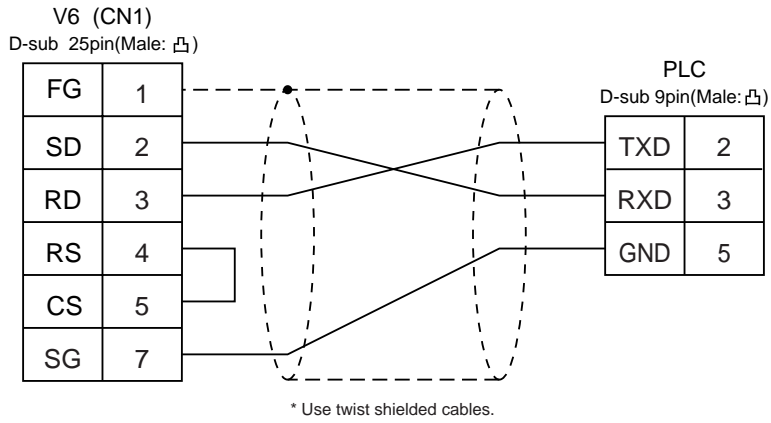

RS-422

Wiring Diagram 2

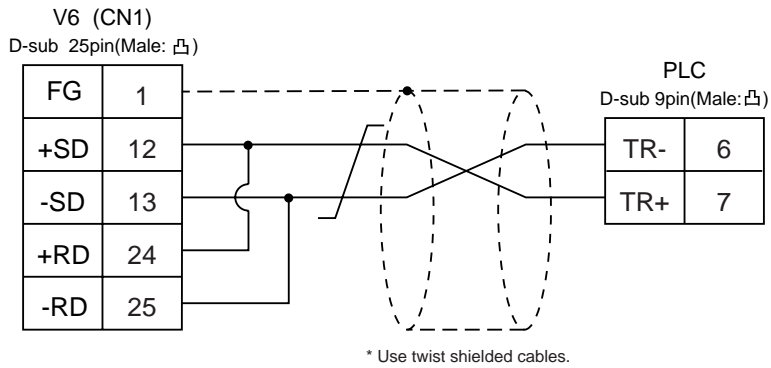

38 KEYENCE PLC • 1

(KZ series link)

Available PLC

Select PLC Type	PLC	Link Unit	Wiring Diagram (refer to P2-104)
KZ Series link	KZ300 KZ350	KZ-L2	Port 1 RS-232C [Wiring Diagram 1] Port 2 RS-232C [Wiring Diagram 2] RS-422 [Wiring Diagram 3]

Communication Setting

The recommended communication parameter setting of both PLC and V6 is as follows:
For further information, refer to the communication specifications of KEYENCE link unit.

Item	Setting of PLC	Comm. Parameter of V6
Port	0	0
Baud Rate	19200bps	19200bps
Parity	Even	Even
Transmission Code	Data Length	7 (ASCII)
	Stop Bit	2
Terminal Resistor	ON for RS-422	_____

Set the port with the port setting switch, the terminating resistance with terminator, and the baud rate/data bit/parity/stop bit with SET B dip switches.

Available Memory

Memory	TYPE	Remarks
DM (data memory)	0	
CH (input/output relay)	1	

**Set the memory to the extent of the memory range of each PLC model.
Use TYPE number to assign indirect memory for macro programs.**

Wiring

The following is a diagram to show the wiring of the cable which connects V6 to PLC.

RS-232C

Wiring Diagram 1

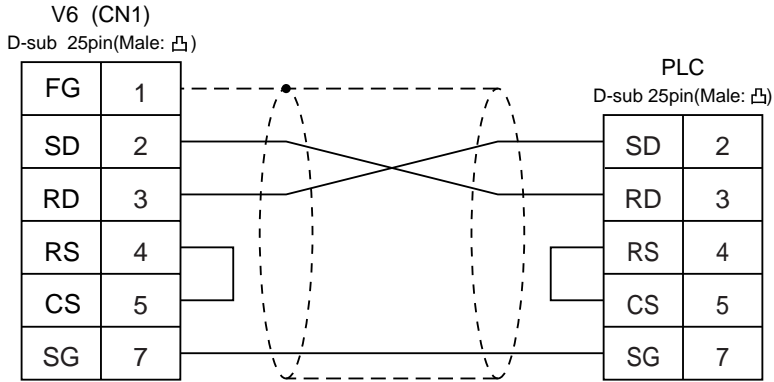

* Use twist shielded cables.

Wiring Diagram 2

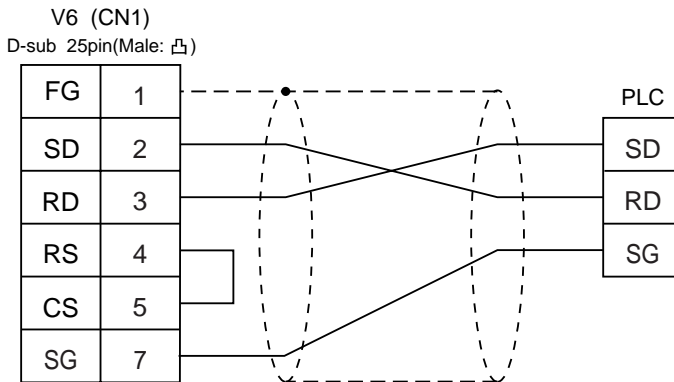

* Use twist shielded cables.

RS-422

Wiring Diagram 3

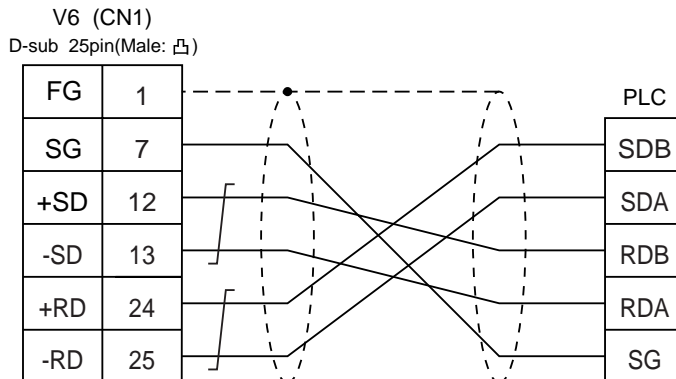

* Use twist shielded cables.

39 KEYENCE PLC • 2

(KZ-A500)

Available PLC

Select PLC Type	PLC	Link Unit	Wiring Diagram (refer to P2-106,107)
KZ-A500 CPU	KZ-A500	CPU Modular Port	RS-232C [Wiring Diagram 1] RS-422 Cable made by KEYENCE [KZ-C20] + Cable made by Hakko [MB-CPUQ]
MITSUBISHI A series link		KZ-L10	Port 1 RS-232C [Wiring Diagram 2] Port 2 RS-232C [Wiring Diagram 3] RS-422 [Wiring Diagram 4]

Communication Setting

The recommended communication parameter setting of both PLC and V6 is as follows:

◆CPU modular port of KZ-A500

Item	Setting of PLC	Comm. Parameter of V6
Port	0	0
Baud Rate	9600bps	9600bps * 1
Parity	Odd	Odd
Transmission Code	Data Length	8
	Stop Bit	1
Terminal Resistor	ON for RS-422	_____

*1 In case of RS-422, the baud rate is fixed at 9600bps.

◆Link Unit KZ-L10

Item	Setting of PLC	Comm. Parameter of V6
Port	0	0
Baud Rate	19200bps	19200bps
Parity	Even	Even
Transmission Code	Data Length	7
	Stop Bit	1
Sum check	Provided (fixed)	_____
Terminal Resistor	ON for RS-422	_____

Set the port with the port setting switch, the terminating resistance with terminator, and the baud rate/data bit/parity/stop bit with SET B dip switches.

For further information, refer to the communication specifications of KZ-L10.

Available Memory

Memory	TYPE	Remarks
D (data register)	0	
W (link register)	1	
R (file register)	2	
TN (timer/current value)	3	
CN (counter/current value)	4	
M (internal relay)	6	
L (latch relay)	7	
B (link relay)	8	
X (input relay)	9	
Y (output relay)	10	
TS (timer/contact)	11	
TC (timer/coil)	12	
CS (counter/contact)	13	
CC (counter/coil)	14	

Set the memory to the extent of the memory range of each PLC model.

Use TYPE number to assign indirect memory for macro programs.

Wiring

The following is a diagram to show the wiring of the cable which connects V6 to PLC.

RS-232C

Wiring Diagram 1

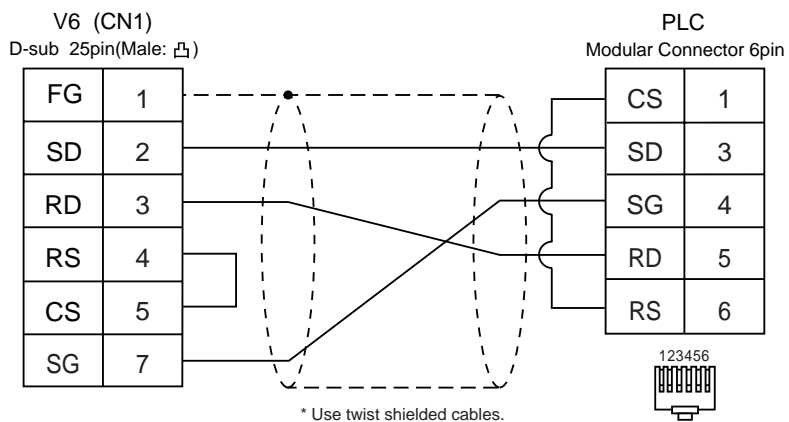

Wiring Diagram 2

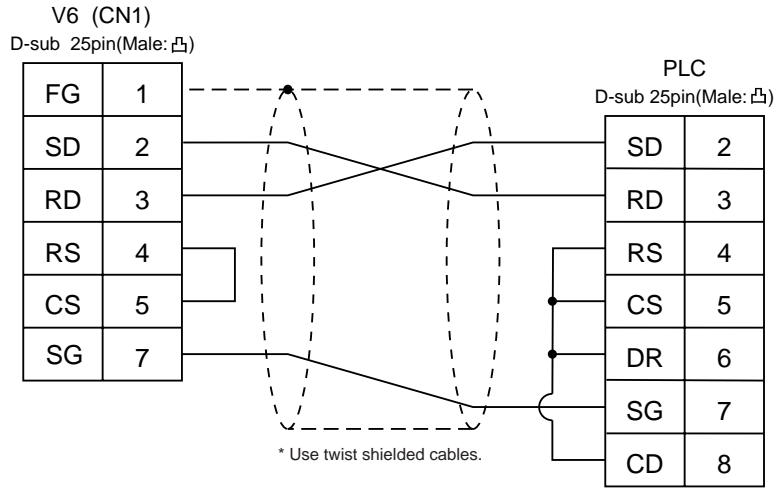

Wiring Diagram 3

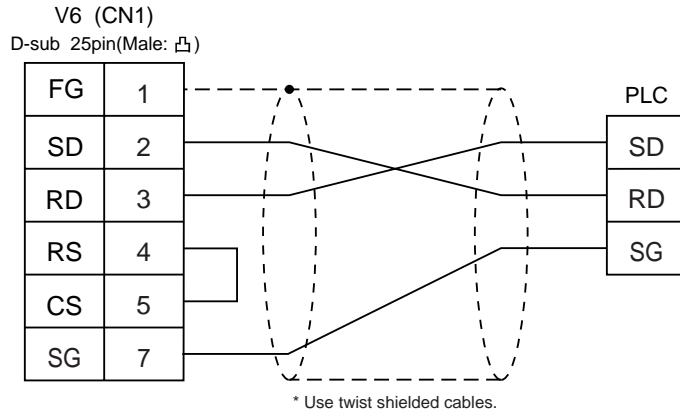

RS-422

Wiring Diagram 4

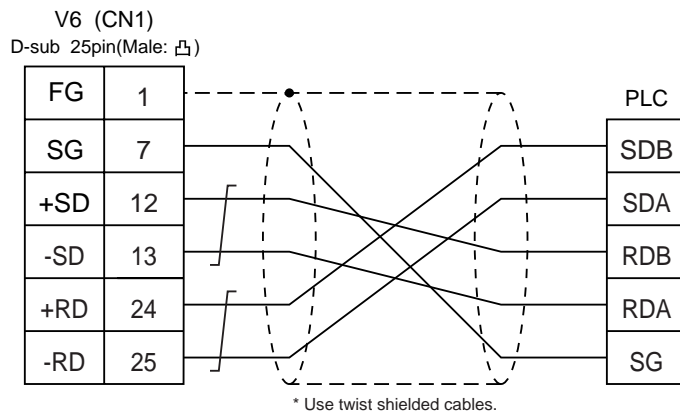

40 KEYENCE PLC • 3

(KZ/KV series CPU)

Available PLC

Select PLC Type	PLC	Wiring Diagram (refer to P2-109)
KZ/KV series CPU	KZ-10,16,24,40,80,300,350 (Program port direct connection) KV series (Program port direct connection)	RS-232C [Wiring diagram 1] or Cable made by KEYENCE [OP-26487] + connector [OP26485] RS-422 Cable made by KEYENCE [KZ-C20] + Cable made by Hakko [MB-CPUQ]
KZ 24/300 CPU	KZ-24,300 (Program port direct connection)	RS-232C [Wiring diagram 1] or Cable made by KEYENCE [OP-26487] + connector [OP26485]
KV 10/24 CPU	KZ-V10,24 (Program port direct connection)	
KV 700 CPU	KV 700 (Program port direct connection)	

* When using RS-232C cable made by KEYENCE [OP-26487], attach the D-sub 25 pins connector [OP-26485] to the modular jack on the V6 side to communicate.

Communication Setting

- KZ/KV series CPU

The communication parameter setting of V6 is done automatically.

- KZ24/300 CPU

Item	Setting of PLC	Comm. Parameter of V6
Port	0	0
Baud Rate	38400bps	38400bps ^{*1}
Parity	Even	_____
Transmission Code	Data Length	8
	Stop Bit	1

*1 The maximum baud rate is 38400bps. If 57600bps or 115000bps is selected, the V6 communicates with a PLC forcibly at 9600bps.

- KV10/24 CPU

Item	Setting of PLC	Comm. Parameter of V6
Port	0	0
Baud Rate	57600bps	57600bps ^{*1}
Parity	Even	_____
Transmission Code	Data Length	8
	Stop Bit	1

*1 The maximum baud rate is 57600bps. If 115000bps is selected, the V6 communicates with a PLC forcibly at 9600bps.

- KV 700 Series CPU

Item	Setting of PLC	Comm. Parameter of V6
Port	0	0
Baud Rate	9600bps	9600bps ^{*1}
Parity	Even	_____
Transmission Code	Data Length	8
	Stop Bit	1

*1 The maximum baud rate is 57600bps.

Available Memory

Memory	TYPE	Remarks
DM (data memory)	0	
CH (input/output relay)	1	
TC (timer/current value)	2	
CC (counter/current value)	3	
TS (timer/set value)	4	
CS (counter/set value)	5	
T (timer/contact)	6	
C (counter/contact)	7	
TM (temporary data memory)	8	
CTH (*1)	9	only in KV700
CTC (*2)	10	only in KV700
CT (*3)	11	only in KV700
CR (control relay)	12	only in KV700
CM (control memory)	13	only in KV700

*1 high-speed counter/current value

*2 high-speed counter comparator/set value

*3 High-speed counter comparator/contact

Set the memory to the extent of the memory range of each PLC model.

Use TYPE number to assign indirect memory for macro programs.

Wiring

The following is a diagram to show the wiring of the cable which connects V6 to PLC.

RS-232C

Wiring Diagram 1

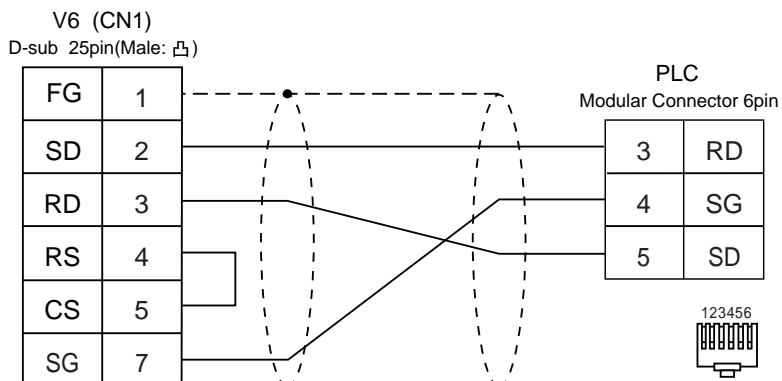

* Use twist shielded cables.

41 LG PLC

Available PLC

Select PLC Type	PLC	Wiring Diagram (refer to P2-113,114)
MASTER-K10/60/200	K10/60/200	RS-232C [Wiring Diagram 1]
MASTER-K500/1000	K500/1000	RS-232C [Wiring Diagram 2] RS-422 [Wiring Diagram 6]
MASTER-KxxxS	K200S/K300S/K1000S CPU port	RS-232C [Wiring Diagram 3]
MASTER-KxxxS CNET	K4F-CUEA	RS-232C [Wiring Diagram 4]
GLOFA CNET	G4L-CUEA	RS-422 [Wiring Diagram 7]
GLOFA GM series CPU	GM4/GM6/GM7 CPU port	RS-232C [Wiring Diagram 5]

Communication Setting

The recommended communication parameter setting of both PLC and V6 is as follows:

○ MASTER-K10/60/200

Item		Setting of PLC	Comm. Parameter of V6
Baud Rate		9600bps (fixed)	_____
Parity		None (fixed)	_____
Transmission Code	Data Length	8 (fixed)	_____
	Stop Bit	1 (fixed)	_____

○ MASTER-K500/1000

Item		Setting of PLC	Comm. Parameter of V6
Baud Rate		19200bps *1	19200bps
Parity		None (fixed)	_____
Transmission Code	Data Length	8 (fixed)	_____
	Stop Bit	1 (fixed)	_____

*1 In case of RS-422, the baud rate is fixed at 9600bps.

○ MASTER-KxxxS

Item		Setting of PLC	Comm. Parameter of V6
Baud Rate		38400bps	38400bps
Parity		None (fixed)	_____
Transmission Code	Data Length	8 (fixed)	_____
	Stop Bit	1 (fixed)	_____

- MASTER-KxxxSCNET/GLOFACNET/GMseriesCPU

Item		Setting of PLC	Comm. Parameter of V6
Baud Rate		38400bps	38400bps
Parity		None	None
Transmission Code	Data Length	8	8
	Stop Bit	1	1

Available Memory

- MASTER-K10/60/200

Memory	TYPE	Remarks
D (data register)	0	
M (auxiliary relay)	1	
P (input/output relay)	2	Input : Read only
K (keep relay)	3	
TC (timer/current value)	4	
CC (counter/current value)	5	
TS (timer/set value)	6	
CS (counter/set value)	7	

- MASTER-K500/1000

Memory	TYPE	Remarks
P (input/output)	0	Input : read only
M (relay)	1	
L (link relay)	2	
K (keep relay)	3	
F (special relay)	4	Read only
T (timer/current value)	5	
C (counter/set value)	6	
D (data register)	7	

○ MASTER-KxxxS

Memory	TYPE	Remarks
P (input/output)	0	Input : read only
M (relay)	1	
L (link relay)	2	
K (keep relay)	3	
F (special relay)	4	Read only
T (timer/current value)	5	
C (counter/set value)	6	
D (data register)	7	
TC (timer/contact)	9	
CC (counter/contact)	10	

○ MASTER-KxxxSCNET

Memory	TYPE	Remarks
P (input/output)	0	Input : read only PW as word device
M (relay)	1	MW as word device
L (link relay)	2	LW as word device
K (keep relay)	3	KW as word device
F (special relay)	4	Read only FW as word device
T (timer/current value)	5	
C (counter/set value)	6	
D (data register)	7	
TC (timer/contact)	9	
CC (counter/contact)	10	

○ GLOFACNET/GMseriesCPU

Memory	TYPE	Remarks
M (internal memory)	0	MW as word device
Q (output)	1	QW as word device
I (input)	2	IW as word device

Set the memory to the extent of the memory range of each PLC model.

Use TYPE number to assign indirect memory for macro programs.

Wiring

The following is a diagram to show the wiring of the cable which connects V6 to PLC.

RS-232C

Wiring Diagram 1

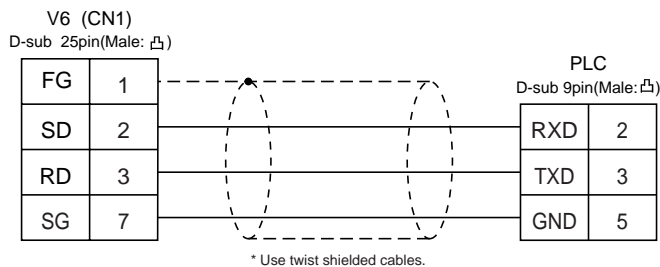

Wiring Diagram 2

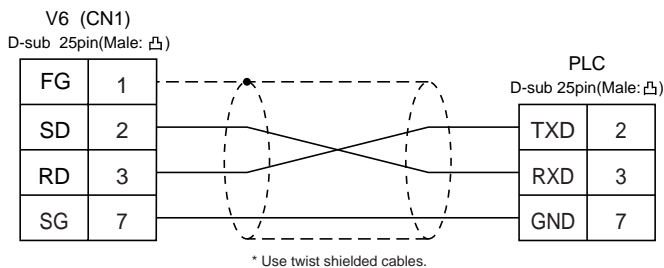

Wiring Diagram 3

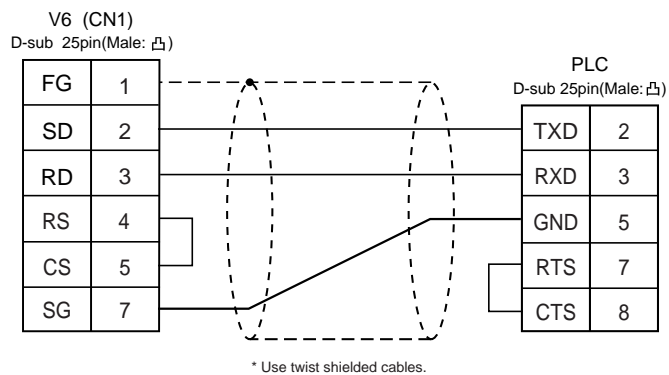

Wiring Diagram 4

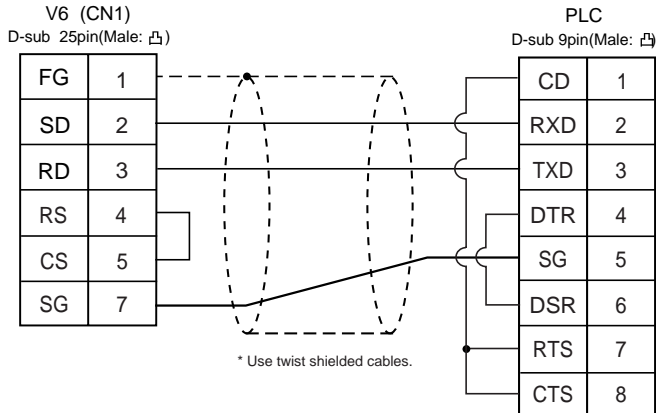

Wiring Diagram 5

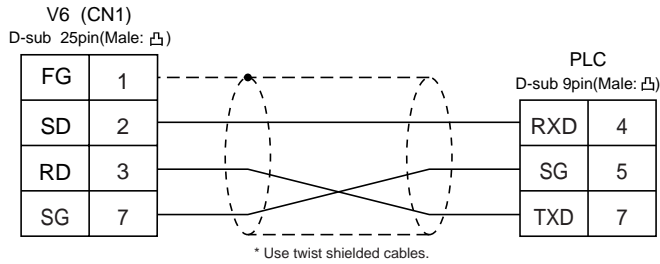

RS-422

Wiring Diagram 6

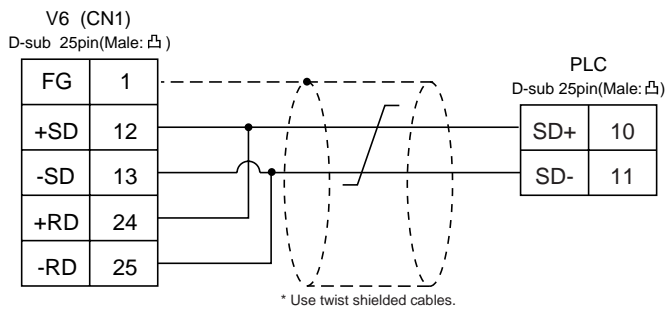

Wiring Diagram 7

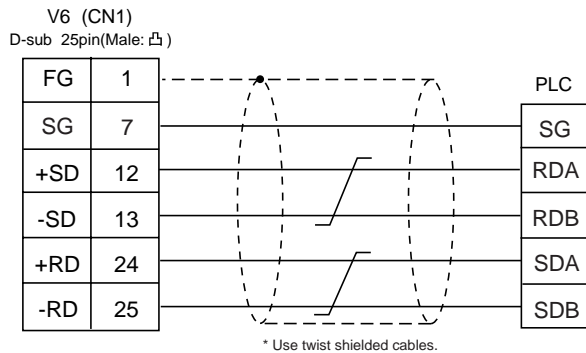

42 FANUC PLC

Available PLC

Select PLC Type	PLC	Wiring Diagram (refer to P2-116)
Power Mate	Port of CPU unit (JD14) of Power Mate-Model H/D	RS-422 [Wiring Diagram 2]
	Power Mate i Model H/D	RS-232C [Wiring Diagram 1] RS-422 [Wiring Diagram 3]

Communication Setting

The recommended communication parameter setting of both PLC and V6 is as follows:

Item	Setting of PLC	Comm. Parameter of V6
Baud Rate	19200bps (fixed)	_____
Signal	RS-422 (fixed)	_____
Port	0 (fixed)	_____
Parity	Even (fixed)	_____
Transmission Code	Data Length	8 (fixed)
	Stop Bit	1 (fixed)

Available Memory

Memory	TYPE	Remarks
D (data register)	0	
X (input relay)	1	WX as word data
Y (output relay)	2	WY as word data
R (internal relay)	3	WR as word data
K (keep relay)	4	WK as word data
T (timer)	5	
C (counter)	6	

Set the memory to the extent of the memory range of each PLC model.
Use TYPE number to assign indirect memory for macro programs.

Wiring

The following is a diagram to show the wiring of the cable which connects V6 to PLC.

RS-232C

Wiring Diagram 1

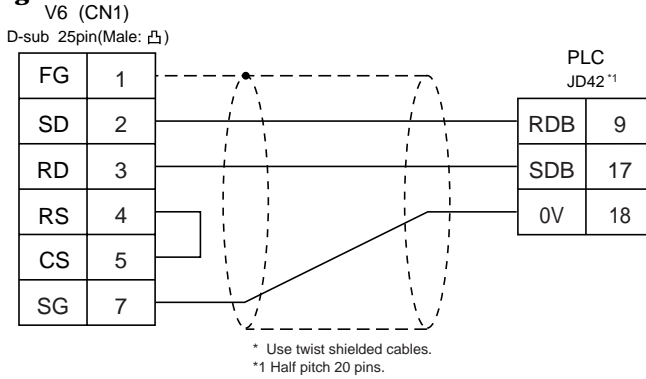

RS-422

Wiring Diagram 2

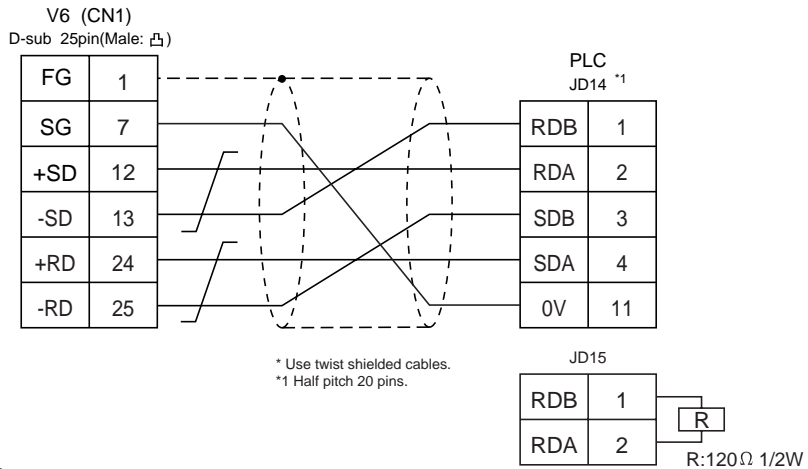

Wiring Diagram 3

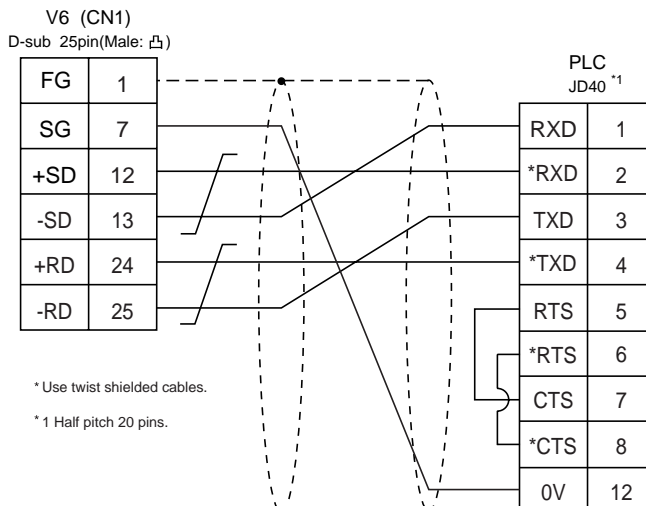

43 FATEK AUTOMATION PLC

Available PLC

Select PLC Type	PLC	Link Unit	Wiring Diagram (refer to P2-118)
FACON FB series	FACON FB series	FB-DTBR	RS-232C [Wiring Diagram 1] [Wiring Diagram 2] RS-422 [Wiring Diagram 3]

Communication Setting

The recommended communication parameter setting of both PLC and V6 is as follows:

Item		Setting of PLC	Comm. Parameter of V6
Baud Rate		9600bps	9600bps
Signal		RS232C	RS232C
Parity		Even (fixed)	_____
Transmission code	Data Length	7 (fixed)	_____
	Stop Bit	1 (fixed)	_____

Available Memory

Memory	TYPE	Remarks
HR (data register)	0	
DR (data register)	1	
X (input relay)	2	
Y (output relay)	3	
M (internal relay)	4	
S (step relay)	5	
T (timer contact)	6	Read only
C (counter contact)	7	Read only
RT (timer/current value)	8	
RC (counter/current value)	9	
DRC (32-bit counter/current value)	10	

Set the memory to the extent of the memory range of each PLC model.

Use TYPE number to assign indirect memory for macro programs.

Wiring

The following is a diagram to show the wiring of the cable which connects V6 to PLC.

RS-232C

Wiring Diagram 1

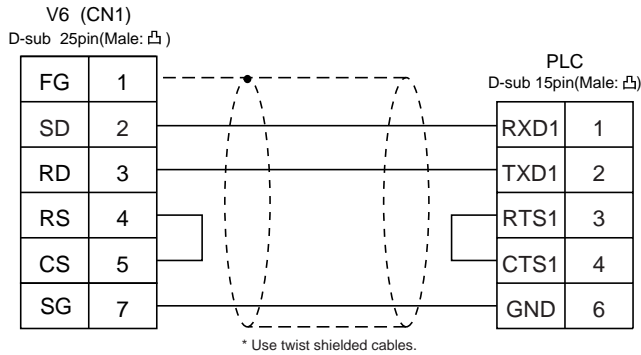

Wiring Diagram 2

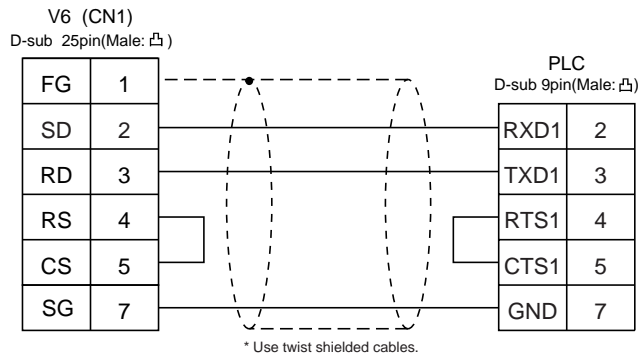

RS-422

Wiring Diagram 3

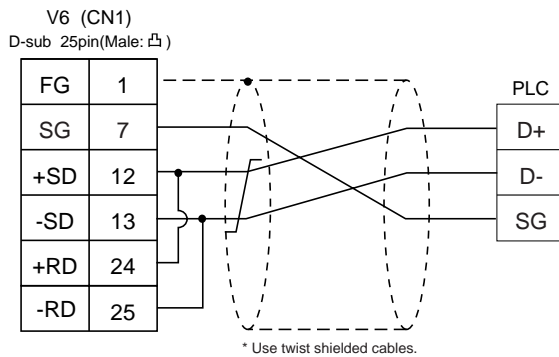

44 IDEC PLC

Available PLC

Select PLC Type	PLC	Wiring Diagram (refer to P2-120)
MICRO3	MICRO3	RS-232C Cable made by IDEC [FC2A-KC1] or * Cable made by IDEC [FC2A-KC2] +RS-232C [Wiring Diagram 1]
MICRO Smart	MICRO Smart	RS-232C * Cable made by IDEC [FC2A-KC4C] +RS-232C [Wiring Diagram 1]

- * When using RS-232C cable made by IDEC [FC2A-KC2] or [FC2A-KC4C], connect the cable of [Wiring Diagram 1] to the D-sub 9 pin side of [FC2A-KC2] or [FC2A-KC4C], to communicate with V6.

Communication Setting

The recommended communication parameter setting of both PLC and V6 is as follows:

Item	Setting of PLC	Comm. Parameter of V6
Baud Rate	9600bps	9600bps
Port	1	1
Parity	Even	Even
Transmission code	Data Length	7
	Stop Bit	1

Available Memory

Memory	TYPE	Remarks
D (data register)	0	
I (input)	1	
Q (output)	2	
M (internal relay)	3	
R (shift register)	4	
TS (timer/set value)	5	
TN (timer/contact)	6	
T (timer/contact)	7	Read only
CS (counter/set value)	8	
CN (counter/current value)	9	
C (counter/contact)	10	Read only

Set the memory to the extent of the memory range of each PLC model.
Use TYPE number to assign indirect memory for macro programs.

Wiring

The following is a diagram to show the wiring of the cable which connects V6 to PLC.

RS-232C

Wiring Diagram 1

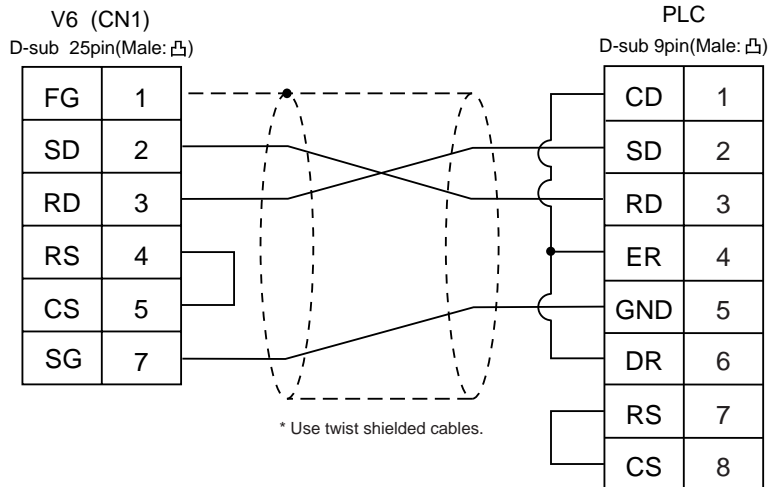

45 MODICON PLC

Available PLC

Select PLC Type	PLC	Wiring Diagram (refer to P2-122)
Modbus RTU	Modbus RTU	RS-232C [Wiring Diagram 1]

Communication Setting

The recommended communication parameter setting of both PLC and V6 is as follows:

Item	Setting of PLC	Comm. Parameter of V6
Baud Rate	9600bps	9600bps
Port	1	1
Parity	Even	Even
Transmission code	Data Length	8
	Stop Bit	1

Available Memory

Memory	TYPE	Remarks
4 (holding register)	0	
3 (input register)	1	
0 (output coil)	4	
1 (input relay)	6	Read only

**Set the memory to the extent of the memory range of each PLC model.
Use TYPE number to assign indirect memory for macro programs.**

Wiring

The following is a diagram to show the wiring of the cable which connects V6 to PLC.

RS-232C

Wiring Diagram 1

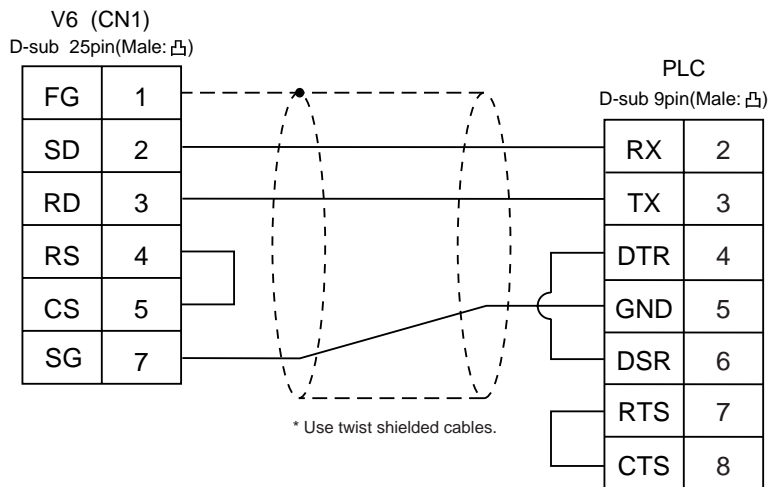

46 YAMATAKE PLC

Available PLC

Select PLC Type	PLC	Wiring Diagram (refer to P2-124)
MX series	MX200/MX50	RS-232C [Wiring Diagram 1]

Communication Setting

The recommended communication parameter setting of both PLC and V6 is as follows:

Item		Setting of PLC	Comm. Parameter of V6
Baud Rate		9600bps	9600bps
Port		1	1
Parity		Even	Even
Transmission code	Data Length	8	8
	Stop Bit	1	1

Available Memory

Memory	TYPE	Remarks
R (data register)	0	
M (auxiliary relay)	1	
L (latch relay)	2	
X (input relay)	3	
Y (output relay)	4	
TP (timer-current value)	5	
TS (timer/set value)	6	
CP (counter-current value)	7	
CS (counter/set value)	8	
T (timer/contact)	9	
C (counter/contact)	10	
P (link register)	11	

Set the memory to the extent of the memory range of each PLC model.

Use TYPE number to assign indirect memory for macro programs.

Wiring

The following is a diagram to show the wiring of the cable which connects V6 to PLC.

RS-232C

Wiring Diagram 1

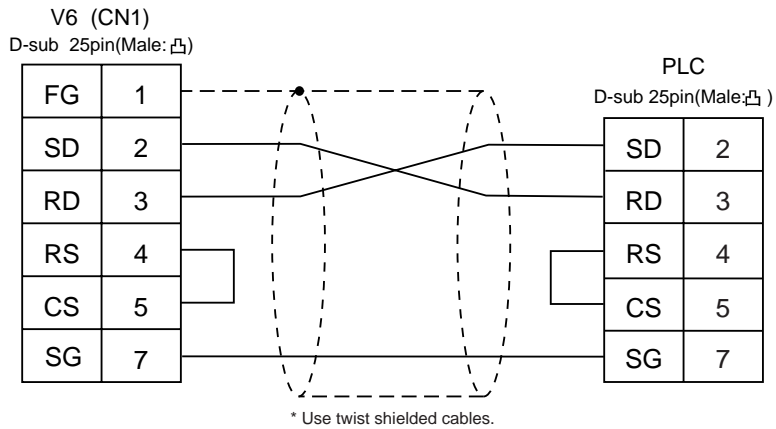

47 TAIAN PLC

Available PLC

Select PLC Type	PLC	Port	Wiring Diagram (refer to P2-126)
TP02	TP02	Communication Port (T/R+, T/R-) MMI Port (9pin) (4-5 Short Computer Link Mode)	RS-422 [Wiring Diagram 1] RS-422 [Wiring Diagram 2]

Communication Setting

The recommended communication parameter setting of both PLC and V6 is as follows:

Item	Setting of PLC	Comm. Parameter of V6
Baud Rate	19200bps	19200bps
Port	1	1
Parity	None	None
Transmission code	Data Length	7
	Stop Bit	1

Available Memory

Memory	TYPE	Remarks
D (data register timer · counter/contact)	0	
V (timer · counter/contact)	1	
WS (system register)	2	
WC (constant register)	3	
X (input relay)	4	
Y (output relay)	5	
C (internal relay)	6	
SC (special register)	7	

**Set the memory to the extent of the memory range of each PLC model.
Use TYPE number to assign indirect memory for macro programs.**

Wiring

The following is a diagram to show the wiring of the cable which connects V6 to PLC.

RS-422

Wiring Diagram 1

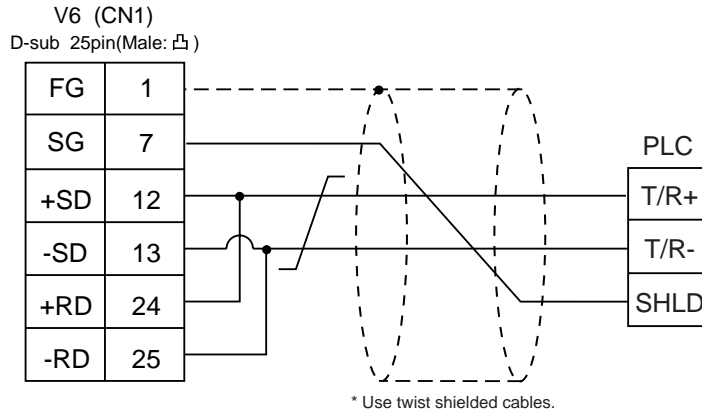

Wiring Diagram 2

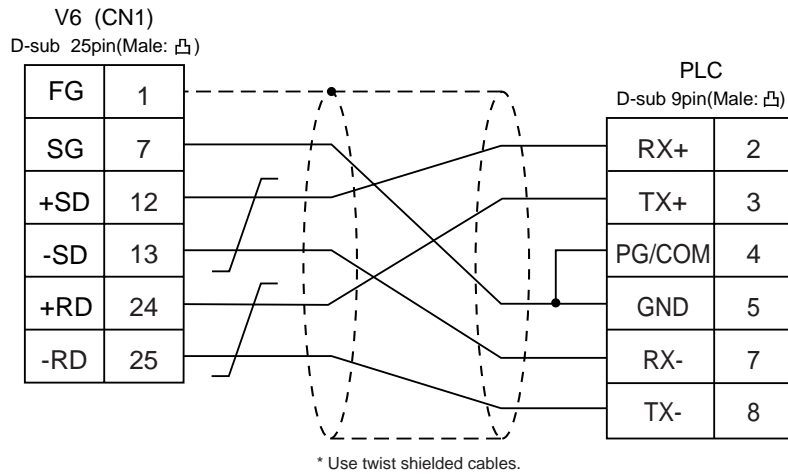

48 SAIA PLC

Available PLC

Select PLC Type	PLC	Communication module	Wiring Diagram (refer to P2-128)
PCD	PCD1	PGU port PCD7.F120 PCD4.F110	RS-232C [Wiring Diagram 1] RS-232C [Wiring Diagram 2] RS-485 [Wiring Diagram 3]

Communication Setting

The recommended communication parameter setting of both PLC and V6 is as follows:

Item		Setting of PLC	Comm. Parameter of V6
Baud Rate		19200bps	19200bps
Port		0	0
Transmission code	Data Length	8	8
	Stop Bit	1	1

S-BUS Configuration

S-BUS Mode Parity
 PGU Port Number 0 (PGU port), 1 (PCD7.F120, PCD4.F110)

Available Memory

Memory	TYPE	Remarks
R (Register Word)	0	
Rfp (Float)	1	
T (Timer-Counter Word)	2	
C (Timer-Counter Coil)	3	
I (Input Bit)	4	read only
O (Output Bit)	5	
F (Flag Bit)	6	

Set the memory to the extent of the memory range of each PLC model.

Use TYPE number to assign indirect memory for macro programs.

Wiring

The following is a diagram to show the wiring of the cable which connects V6 to PLC.

RS-232C

Wiring Diagram 1

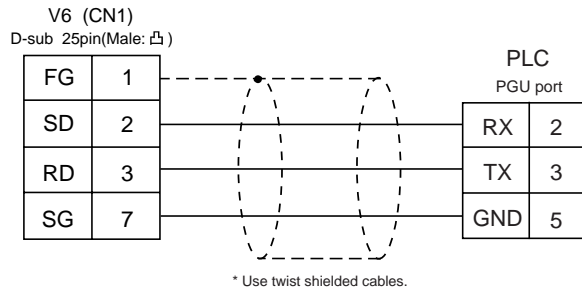

Wiring Diagram 2

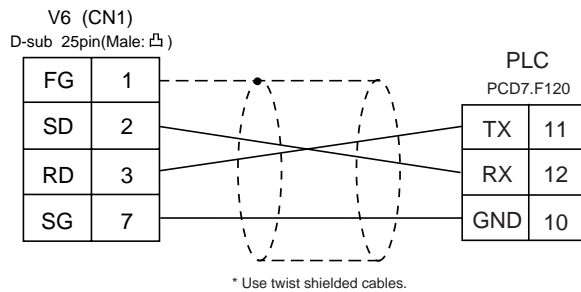

RS-485

Wiring Diagram 3

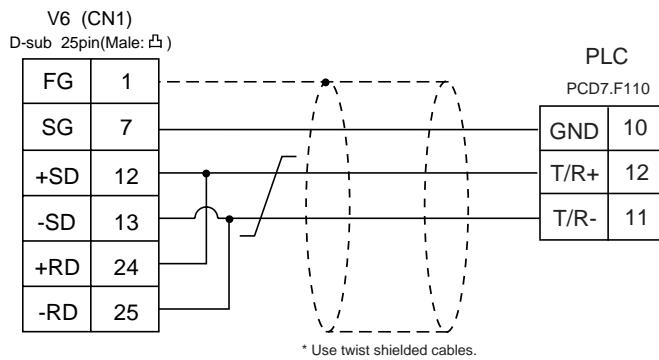

49 MOELLER PLC

Available PLC

Select PLC Type	PLC	Wiring Diagram(refer to P2-129)
PS4	PS4-201-MM1(PRG port)	RS-232C [Wiring Diagram 1] + ZB4-303-KB1 Cable made by MOELLER

Communication Setting

The recommended communication parameter setting of both PLC and V6 is as follows:

Item	Setting of PLC	Comm. Parameter of V6
Baud Rate	9600bps	9600bps
Port	1	1
Parity	None	None
Transmission code	Data Length	8
	Stop Bit	1

Available Memory

Memory	TYPE	Remarks
M (Marker)	0	MW as word device

Set the memory to the extent of the memory range of each PLC model.

Use TYPE number to assign indirect memory for macro programs.

Wiring

The following is a diagram to show the wiring of the cable which connects V6 to PLC.

RS-232C

Wiring Diagram 1

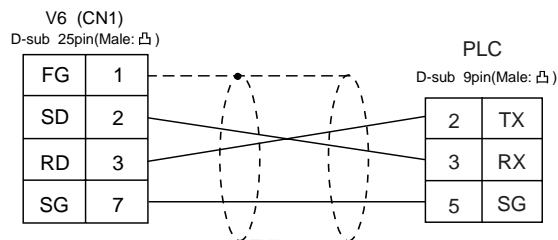

* Use twist shielded cables.

50 Telemecanique PLC

Available PLC

Select PLC Type	PLC	Wiring Diagram (refer to P2-131)
TSX Micro	TSX Micro	RS-485 [Wiring Diagram 1]

Communication Setting

The recommended communication parameter setting of both PLC and V6 is as follows:

Item	Setting of PLC	Comm. Parameter of V6
Baud Rate	9600bps	9600bps
Connection	—————	Multi-Link (fixed)
Parity	Odd	Odd
Transmission Code	Data Length	8 (fixed)
	Stop Bit	1

Available Memory

Memory	TYPE	Remarks
MW (memory Word)	0	
KW (constant word)	1	
M (bit memory)	2	

Set the memory to the extent of the memory range of each PLC model.

Use TYPE number to assign indirect memory for macro programs.

Wiring

The following is a diagram to show the wiring of the cable which connects V6 to PLC.

RS-485

Wiring Diagram 1

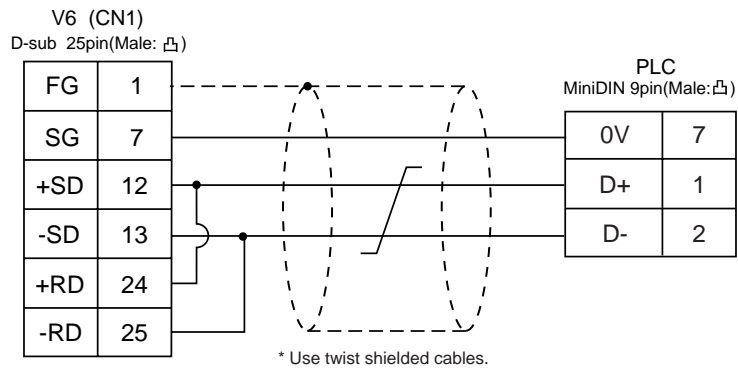

51 Automationdirect PLC

Available PLC

Select PLC Type	PLC	Link Unit	Wiring Diagram (refer to P2-133, 134)
Direct LOGIC	D4-430 D4-440	Port 1 on a CPU unit	RS-232C [Wiring Diagram 1] RS-422 [Wiring Diagram 5]
	D4-450	Port 3 on a CPU unit	RS-485 [Wiring Diagram 6]
		Port 2 on a CPU unit	RS-232C [Wiring Diagram 2]
	D2-240	Port 2 on a CPU unit	
	D2-250	Port 2 on a CPU unit	RS-232C [Wiring Diagram 3]
Direct LOGIC (K-Sequence)	D4-430 D4-440	Port 1 on a CPU unit	RS-232C [Wiring Diagram 1] RS-422 [Wiring Diagram 5]
	D4-450	Port 0 on a CPU unit	RS-232C [Wiring Diagram 4]
		Port 3 on a CPU unit	RS-485 [Wiring Diagram 6]
		Port 2 on a CPU unit	
	D2-240	Port 1 on a CPU unit Port 2 on a CPU unit	RS-232C [Wiring Diagram 2]
	D2-250	Port 1 on a CPU unit	
		Port 2 on a CPU unit	RS-232C [Wiring Diagram 3]

Communication Setting

The recommended communication parameter setting of both PLC and V6 is as follows:

Item	Setting of PLC	Comm. Parameter of V6
Baud Rate	19200bps	19200bps
Port	"0" for x10, "1" for x1	1
Parity	Odd	Odd
Transmission Code	Data Length	8
	Stop Bit	1
Function	Host link system (fixed)	_____
Response Delay Time	0 (fixed)	_____
Time-out	None (fixed)	_____
ASCII/HEX	HEX (fixed)	_____

Available Memory

- DirectLOGIC, DirectLOGIC(K-Sequence)

Memory	TYPE	Remarks
V (data register)	0	
X (input relay)	1	
Y (output relay)	2	
C (internal relay)	3	
S (stage)	4	
GX (global inputs)	5	
GY (global outputs)	6	
T (timer/contact)	7	
CT (counter/contact)	8	

**Set the memory to the extent of the memory range of each PLC model.
Use TYPE number to assign indirect memory for macro programs.**

Wiring

The following is a diagram to show the wiring of the cable which connects V6 to PLC.

RS-232C

Wiring Diagram 1

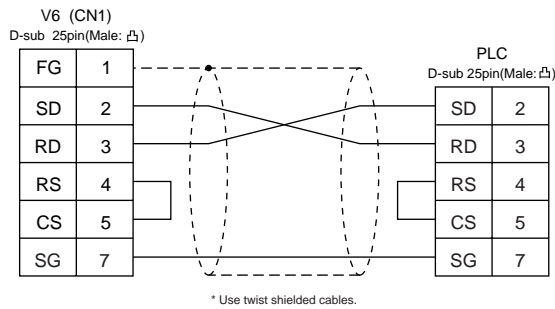

Wiring Diagram 2

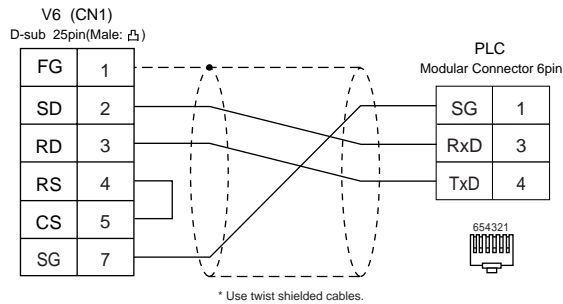

Wiring Diagram 3

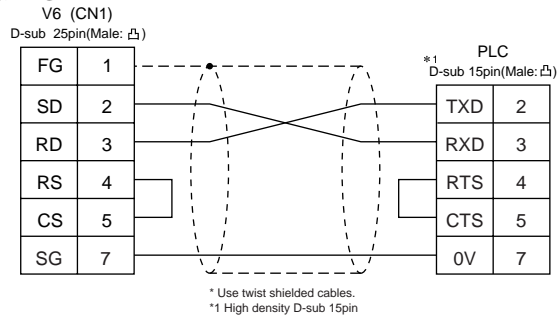

Wiring Diagram 4

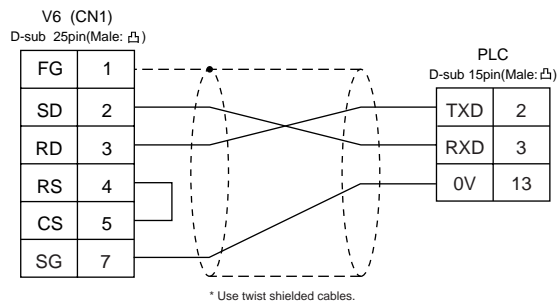

RS-422

Wiring Diagram 5

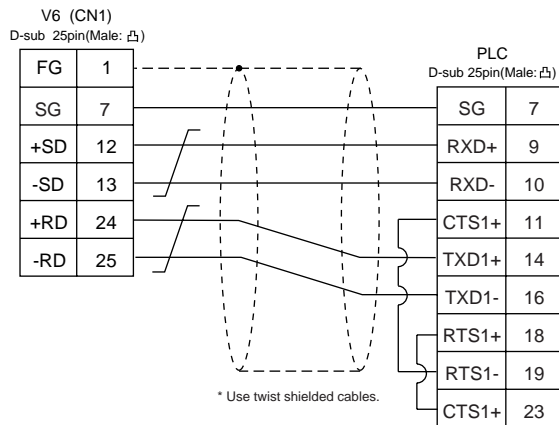

Wiring Diagram 6

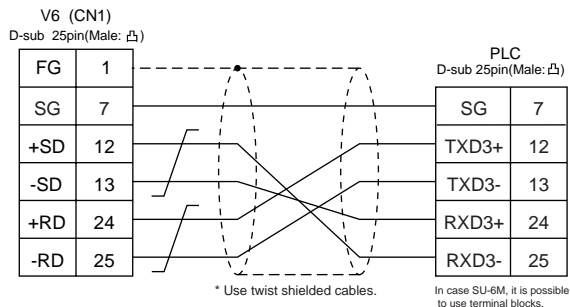

52 VIGOR PLC

Available PLC

Select PLC Type	PLC	Link Unit	Wiring Diagram (refer to P2-136)
M series	M1-CPU1	COM PORT	RS-232C [Wiring Diagram 1] RS-485 [Wiring Diagram 2]

Communication Setting

The recommended communication parameter setting of both PLC and V6 is as follows:

Item	Setting of PLC	Comm. Parameter of V6
Baud Rate	19200bps	19200bps
Port	0	0
Parity	Even	Even
Transmission Code	Data Length	7
	Stop Bit	1

Available Memory

Memory	TYPE	Remarks
D (data register/special register)	0	
X (input relay)	1	
Y (output relay)	2	
M (internal relay/special relay)	3	
S (internal relay/step relay)	4	
T (timer/current value)	5	
C (counter/current value)	6	
32C (high-speed counter/current value)	7	*1
TS (timer/contact)	8	
CS (counter/contact)	9	
TC (timer/coil)	10	
CC (counter/coil)	11	

*1 In case of the items which can display double word data (e.g. data display, graph, sampling), the data is managed as double word data.

Both bit data and word data are managed as lower-half 16 bits data.

Input : 16 upper-half bits are ignored.

Output : "0" is written in the 16 upper-half bits.

Set the memory to the extent of the memory range of each PLC model.

Use TYPE number to assign indirect memory for macro programs.

Wiring

The following is a diagram to show the wiring of the cable which connects V6 to PLC.

RS-232C

Wiring Diagram 1

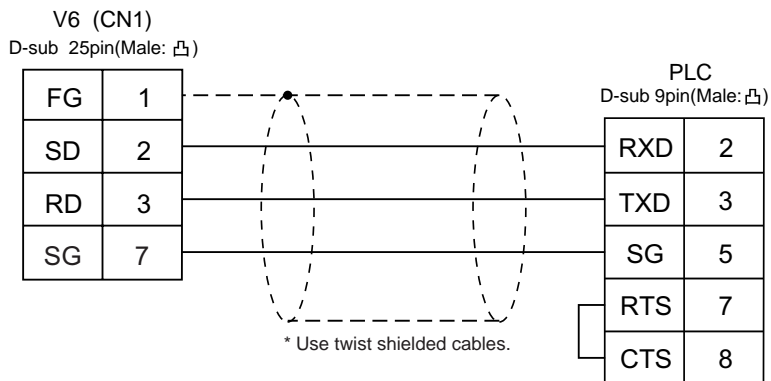

RS-485

Wiring Diagram 2

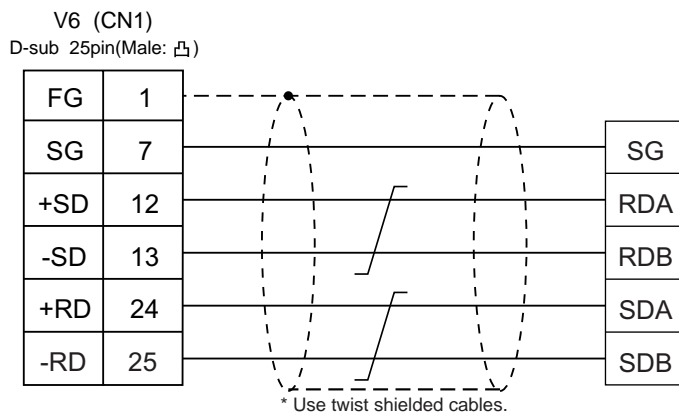

53 DELTA PLC

Available PLC

Select PLC Type	PLC	Link Unit	Wiring Diagram (refer to P2-138)
DVP series	DVP series	RS-485 Communication port	RS-485 [Wiring Diagram 1]

Communication Setting

The recommended communication parameter setting of both PLC and V6 is as follows:

Item	Setting of PLC	Comm. Parameter of V6
Baud Rate	9600bps	9600bps
Port	1	1
Parity	Even	Even
Transmission Code	Data Length	7
	Stop Bit	1

Available Memory

Memory	TYPE	Remarks
D (data register)	0	
X (input relay)	1	
Y (output relay)	2	
M (auxiliary relay)	3	
S	4	
T (timer)	5	
C (counter)	6	
32C (high-speed counter)	7	

**Set the memory to the extent of the memory range of each PLC model.
Use TYPE number to assign indirect memory for macro programs.**

Wiring

The following is a diagram to show the wiring of the cable which connects V6 to PLC.

RS-485

Wiring Diagram 1

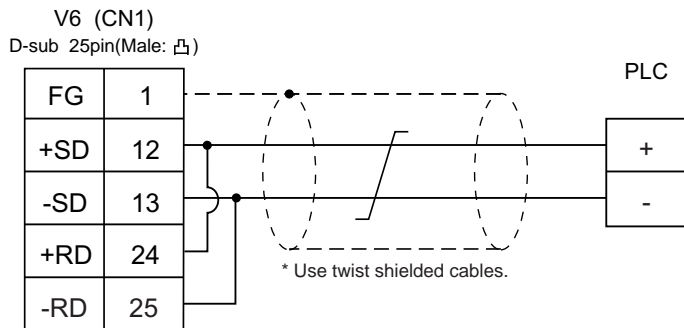

54 BALDOR PLC

Available PLC

Select PLC Type	Controller	Wiring Diagram (refer to P2-140)
Mint	NextMove (Comms Data Array)	RS-232C [Wiring Diagram 1]
	Optimum (Comms Data Array)	

Communication Setting

The recommended communication parameter setting of both PLC and V6 is as follows:

Item	Setting of PLC	Comm. Parameter of V6
Baud Rate	9600bps	9600bps
Port	0	0
Parity	None	None
Transmission Code	Data Length	8
	Stop Bit	1

Available Memory

Memory	TYPE	Remarks
I (Integer)	0	
F (Float)	1	
B (Integer omitting decimals)	2	

**Set the memory to the extent of the memory range of each PLC model.
Use TYPE number to assign indirect memory for macro programs.**

Wiring

The following is a diagram to show the wiring of the cable which connects V6 to PLC.

RS-232C

Wiring Diagram 1

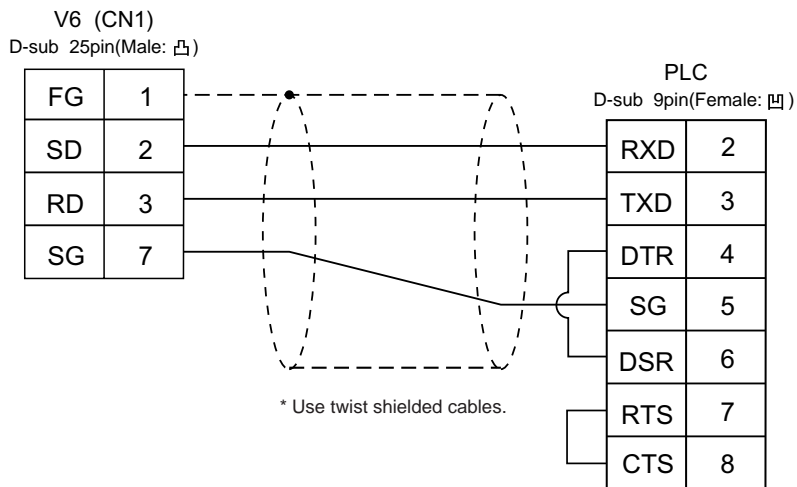

Appendix

Ladder Transfer Function

Ladder Transfer Function

(Transparent Mode)

Up until now it was necessary to debug the data by removing and mounting "connection cable between PC and PLC" and "connection cable between V7 and PLC." When using the ladder transfer function, it is possible to write ladder programs or monitor the PLC memory via V7 series connected to PC without removing and mounting each cable.

Applicable PLC

Select PLC Type	CPU	Ladder comm. prg	I/F DRV
QnH(Q) series CPU	Q02(H), Q06H	MelQHCpQ.lcm	MelQHCpQ.tpb (1.240)
QnH(Q) series link	Q00, Q01	MelQnA.lcm	MelQnA.tpb (1.300)
FX series CPU	FX1/2, FX0N	MelFx.lcm	MelFx.tpb (1.300)
FX2N series CPU	FX2N/1N, FX2NC		
FX1S series CPU	FX1S		

Applicable Types

- V606i, V608, V610, V612, V609E

*This function cannot be supported with 1: communication (multi-drop), multi-link and multi-link2 communication.

- The following types are unavailable for this function.
V606, V608CH

Version and Main Menu Screen

Available versions are as follows. The information can be shown on the [Main Menu] screen.

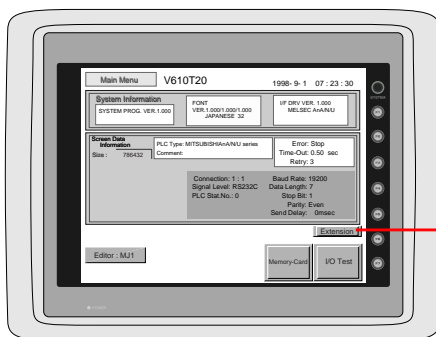

Pressing the [Extension] switch brings to the [Extension Program Info.] screen.

ITEM	Version
SYSTEM PROG.	VER.1.500 or later
FONT	VER.1.210/1.130/1.000 or later

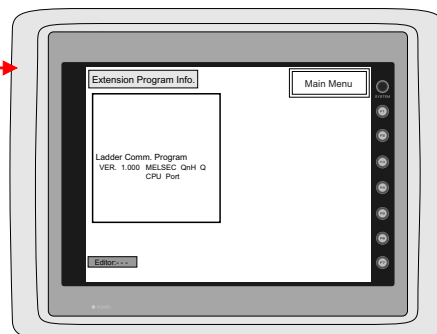

Connection

- Use each 1:1 communication cable when connecting the V6 series (CN1) to the PLC (CPU port).
- Use Hako Electronics V6-CP cable when connecting the computer (PLC programming software) and the V6 series (MJ1/2).

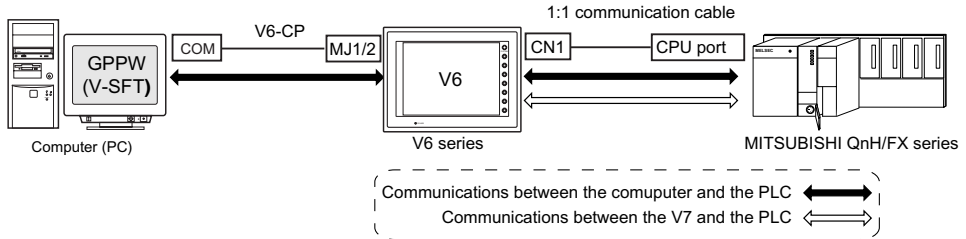

- When using the V-SFT editor and the PLC programming software:

When using two V6-CP cables:

When the computer has two COM ports, use one port for the V-SFT editor and the other port for the PLC programming software. Use the V6-CP cables. (It is not possible to transfer the V-SFT editor and the PLC programming software at the same time.)

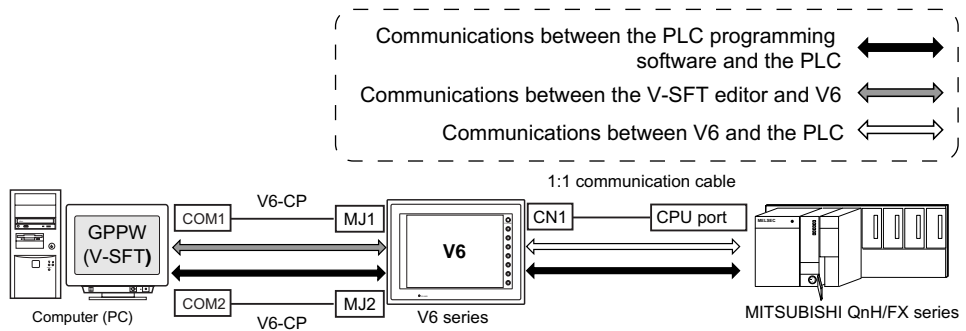

When using one V6-CP cable:

When using the V-SFT editor and the PLC programming software, it is not possible to use one COM port for both purposes at the same time. Stop using both software for communications.

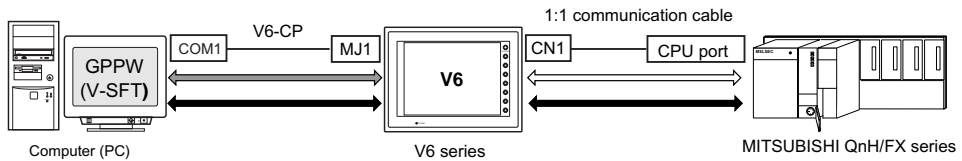

Settings and Communications

1. PLC type setting
Select [PLC Type] from the [System Setting] menu. Select a PLC type available for the ladder transfer function in the [Select PLC Type] dialog.
2. PLC programming software port setting
Select [Modular Jack] from the [System Setting] menu.
Select [Ladder Tool] for [Modular Jack 1] or [Modular Jack 2] in the [Modular Jack] dialog.

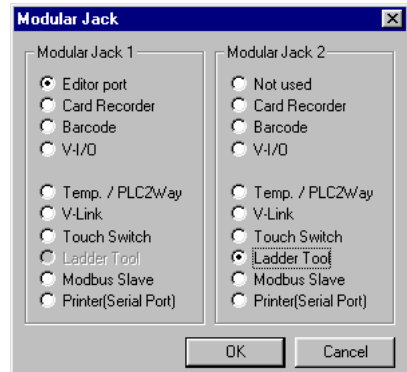

Communications with V-SFT editor (for screen data transfer)

On-line editing between the V-SFT editor and the V6 series is not possible. If attempted, communications between the PLC programming software and the PLC will not be performed correctly.

- With [Ladder Tool] selected for [Modular Jack 2], MJ1 will be [Editor Port] when the Main Menu screen is displayed on the V6 series, and communications with the V-SFT editor become possible.
- With [Ladder Tool] selected for [Modular Jack 1], even when the Main Menu screen is displayed on the V6 series, communications with the PLC programming software continues, but communications with the V-SFT editor are not available.

When communicating with the V-SFT editor, refer to the following two ways.

* **When V609E is used, selected the way of Automatic switching after upgrading system prg. of V609E.**

- Automatic switching (V-SFT ver. 2.0.9.0 or later, sys.prg.ver. 1.570 or later)
Check [Ladder communication is not used in Local mode.] on the [Environment Setting] tab menu of the [Unit Setting] dialog in the [System Setting].
- Manual switching
Hold down the F2 switch for three seconds. [Editor:...] changes to [Editor: MJ1] and communications with the V-SFT editor become possible.

Communications with the PLC programming software possible

Editor: ---

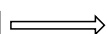

Communications with the V-SFT editor possible

Editor: MJ1

When the F2 switch is held down for three seconds, [Editor: MJ1] changes to [Editor:...] and communications with the PLC programming software become possible.

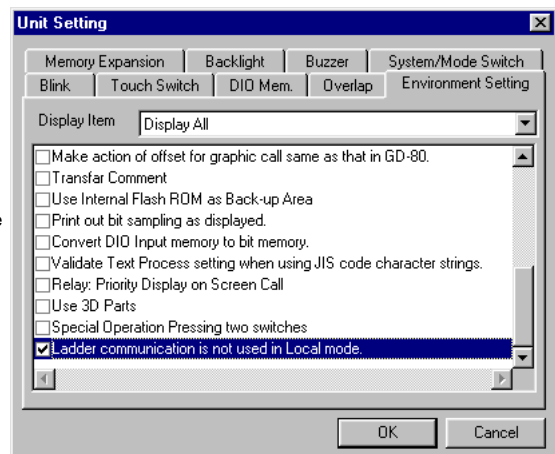

- Communicating statuses with the PLC programming software and the PLC during communications between the V-SFT editor and the V6 series

V-SFT	PLC programming software
Writing to V6	Communications disconnected (normal communications on completion of writing)
Reading from V6	Normal communications
Comparing with V6	Normal communications

3. PLC programming software communication setting

For communications specifications between the PLC programming software and the PLC, the communication parameter settings for the V6 series and the PLC can be used. Select [Comm. Parameter] from the [System Setting] menu and check the settings in the [Comm. Parameter] dialog.

<Baud rate setting>

There will be no problem if the setting for [Baud Rate] in the [Comm. Parameter] dialog of the V-SFT editor is not consistent with the baud rate setting on the PLC programming software. The baud rate set by the PLC programming software is automatically selected when communications (monitoring, etc.) are performed. When the V6 series is turned off and back on, the setting for [Baud Rate] in the [Comm. Parameter] dialog becomes valid again.

*** Setting the same baud rate of both PLC and V6 series makes the performance of V6 series faster.**

4. Transferring the added communication program

When transferring screen data, the ladder communication program is also transferred. To transfer the ladder communication program only, follow the procedure described below.

- Select [Laddercom.prg.] in the [Transfer] dialog, and click [PC->].
- The dialog shown on the right is displayed. Select the laddercom. program for these selected plc type and click [Open]. The program is transferred to the V6 series.

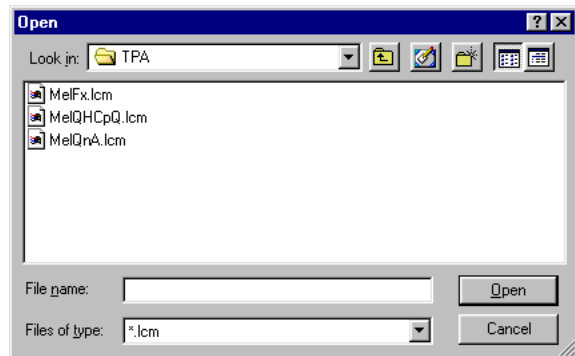

Notes on Ladder Transfer Function

1. When [Ladder Tool] is selected for a modular jack, monitor registration on the PLC is prohibited so that the screen display speed becomes slower than usual during communications between the V6 series and the PLC even if the PLC programming software is not started.
2. Also, when the ladder program is transferred in the RUN mode of the V6 series, communications are synchronized; therefore, the performance of both the V6 series and the PLC programming software decreases.

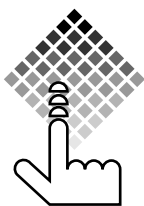

MONITOUCH V6

Hakko Electronics Co., Ltd.

Sales	890-1, Kamikashiwano-machi, Matto-shi, Ishikawa, 924-0035 Japan TEL (076)274-2144 FAX(076)274-5208	
Tokyo Office	TEL (03)3255-0166	FAX(03)3255-0298
Osaka Office	TEL (06)6385-8234	FAX(06)6385-7851
Nagoya Office	TEL (052)789-0096	FAX(052)789-0098
Head Office	238, Kamikashiwano-machi, Matto-shi, Ishikawa, 924-0035 Japan	

PRICE ¥1,000-