

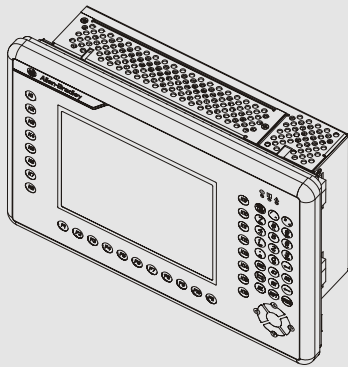

**Allen-Bradley**

*RAC6182 Industrial  
Computer for the  
Windows CE  
Operating System*



# User Manual



## Important User Information

Solid state equipment has operational characteristics differing from those of electromechanical equipment. "Safety Guidelines for the Application, Installation, and Maintenance of Solid State Controls" (Publication SGI-1.1) describes some important differences between solid state equipment and hard-wired electromechanical devices. Because of this difference, and because of the wide variety of uses for solid state equipment, all persons responsible for applying this equipment must satisfy themselves that each intended application of this equipment is acceptable.

In no event will Rockwell Automation be responsible or liable for indirect or consequential damages resulting from the use or application of this equipment.

The examples and diagrams in this manual are included solely for illustrative purposes. Because of the many variables and requirements associated with any particular installation, Rockwell Automation cannot assume responsibility or liability for actual use based on the examples and diagrams.

No patent liability is assumed by Rockwell Automation with respect to use of the information, circuits, equipment, or software described in this manual.

Reproduction of the contents of this manual, in whole or in part, without written permission of Rockwell Automation is prohibited.

Throughout this manual, we use notes to make you aware of safety considerations.



**ATTENTION:** Identifies information about practices or circumstances that can lead to personal injury or death, property damage, or economic loss.

---

**Important:** Identifies information that is especially important for successful application and understanding of the product.

# Table of Contents

---

## Using this Manual

### Preface

Who Should Use This Manual.....	P-1
Purpose of this Manual.....	P-1
Contents of this Manual.....	P-2
Manual Conventions.....	P-3
Allen-Bradley Support.....	P-3

## Computer Features

### Chapter 1

Chapter Objectives .....	1-1
RAC6182 Industrial Computer Versions .....	1-1
RAC6182 Industrial Computer Packing List.....	1-2
RAC6182 Hardware .....	1-2
RAC6182 Software .....	1-2
RAC6182 Ordering Information .....	1-4
Features of the RAC6182 Industrial Computer .....	1-5
LED Indicators .....	1-9

## Installation

### Chapter 2

Chapter Objectives .....	2-1
European Union Compliance.....	2-1
Environmental Considerations .....	2-1
Mounting Hardware.....	2-1
Tools Required.....	2-2
Mounting Clearances.....	2-2
Mounting Dimensions .....	2-3
Mounting Cutouts.....	2-5
Panel Mounting .....	2-5
Power Connections.....	2-7
Relay Output.....	2-8

## Connecting External Devices

### Chapter 3

Chapter Objectives .....	3-1
Safety Precautions .....	3-1
Connecting USB Devices .....	3-2
Connecting PS/2 Keyboard and Mouse.....	3-3
Connecting to an Ethernet Network .....	3-4
Connecting Serial Devices.....	3-6
Connecting Parallel Devices.....	3-7
Connecting an External Video Monitor .....	3-8
Connecting to Relay Output .....	3-9

<b>Adding/Removing Internal Components</b>	<b>Chapter 4</b>	
	Chapter Objectives.....	4-1
	Safety Precautions.....	4-1
	Thermal Considerations for Add-In Cards.....	4-2
	Opening or Removing the Chassis.....	4-2
	Adding/Removing PC Cards (PCMCIA).....	4-4
	Adding/Removing a PCI Card.....	4-6
	Adding/Removing RAM Memory.....	4-8
Adding/Removing DiskOnChip Memory.....	4-9	
<b>Installing/Removing Front Bezel Assembly Items</b>	<b>Chapter 5</b>	
	Chapter Objectives.....	5-1
	Safety Precautions.....	5-1
	Disassembling the Front Bezel.....	5-2
	Replacing the Front Bezel Plastic Overlay.....	5-5
	Installing Keypad Legend Strips.....	5-6
<b>Initial Operation and Setup</b>	<b>Chapter 6</b>	
	Chapter Objectives.....	6-1
	Operating Recommendations.....	6-1
	Operator Access.....	6-1
	System Checkout.....	6-1
	System Reset.....	6-2
<b>Windows CE Operating System</b>	<b>Chapter 7</b>	
	Chapter Objectives.....	7-1
	Windows CE Architecture.....	7-1
	RAC6182 Standard Windows CE Programs.....	7-2
	Using Windows CE.....	7-3
	Control Panel Applications.....	7-6
	RAC6182 Memory Usage.....	7-7
<b>Keypad Operation</b>	<b>Chapter 8</b>	
	Chapter Objectives.....	8-1
	Keypad Operation.....	8-1
	Keypad Layout.....	8-1
	Setting Up the Keypad.....	8-7
	Setting Up and Using the Keypad Configuration Utility Software.....	8-8

---

<b>Display Settings</b>	<b>Chapter 9</b>
	Chapter Objectives ..... 9-1
	Setting Up the Display..... 9-1
<b>Touchscreen Calibration</b>	<b>Chapter 10</b>
	Chapter Objectives ..... 10-1
	Setting Touchscreen Properties..... 10-1
<b>Hardware Monitor</b>	<b>Chapter 11</b>
	Chapter Objective ..... 11-1
	Hardware Monitor System Software ..... 11-1
	Using the Hardware Monitor ..... 11-2
<b>Watchdog Timer</b>	<b>Chapter 12</b>
	Chapter Objective ..... 12-1
	Watchdog Functionality ..... 12-1
	Using the Watchdog Timer System Software ..... 12-2
<b>Communications Configuration</b>	<b>Chapter 13</b>
	Chapter Objectives ..... 13-1
	Setting Up Ethernet Communications ..... 13-1
	Setting Up Serial Communications ..... 13-5
<b>Managing User Applications</b>	<b>Chapter 14</b>
	Chapter Objectives ..... 14-1
	Installing and Using Microsoft ActiveSync..... 14-1
	Installing/Removing Applications on the RAC6182 Computer ..... 14-3
	Transferring Files to and from the RAC6182 Computer ..... 14-4
	Upgrading the RAC6182 Windows CE Operating System ..... 14-4

**System Troubleshooting**

**Chapter 15**

Chapter Objectives ..... 15-1  
 Hardware Diagnostics ..... 15-1  
 Troubleshooting Procedure ..... 15-1  
 Troubleshooting Check Lists ..... 15-2  
 Resetting the Windows CE Registry ..... 15-4

**Maintenance**

**Chapter 16**

Chapter Objectives ..... 16-1  
 Cleaning the Display ..... 16-1  
 Replacing the Battery ..... 16-2  
 Restoring the RAC6182 Computer ..... 16-2

**Replacement Parts and Accessories**

**Chapter 17**

Chapter Objectives ..... 17-1  
 Replacement Parts ..... 17-1

**Specifications**

**Appendix A**

**Processor Board Specifications**

**Appendix B**

Processor Board Specifications ..... B-1  
 Boot Code Information ..... B-1

**RAC6182 Compatible Devices**

**Appendix C**

Parallel Port Printers ..... C-1  
 PC Cards ..... C-1

**RAC6182 Point-to-Point Communications**

**Appendix D**

COM2 RS232 Communications ..... D-1

**Index**

## Using this Manual

Read this preface to familiarize yourself with the rest of the manual. The preface covers the following topics:

- who should use this manual
- the purpose of the manual
- contents of the manual
- conventions used in this manual
- Allen-Bradley support

### Who Should Use This Manual

Use this manual if you are responsible for installing, using, or troubleshooting the RAC6182 Industrial Computer for the Windows CE Operating System.

For users interested in writing their own application software for the RAC6182 Industrial Computer, you will need to order the **6189-SDK** software development kit. This catalog number includes a detailed technical manual describing how to develop software applications for the RAC6182 Industrial Computer, along with a complete library of RAC6182 interfaces and development tools on CD-ROM.

### Purpose of this Manual

This manual is a user guide for the RAC6182 Industrial Computer for the Windows CE Operating System. It gives an overview of the system and describes procedures you use to:

- install the RAC6182 Industrial Computer in a panel or enclosure
- install and remove system components
- run the system
- troubleshoot the system

## Contents of this Manual

Chapter	Title	Contents
	Preface	Describes the purpose, background, and scope of this manual. Also specifies the intended audience.
1	Computer Features	Shows the different versions and features of the RAC6182 Industrial Computer.
2	Installation	Describes how to install the RAC6182 Industrial Computer in a panel or enclosure. Also how to connect power, network, and relay output.
3	Connecting External Devices	Tells how to connect external devices to the various RAC6182 ports.
4	Adding/Removing Internal Components	Gives procedures for adding/removing RAM and ROM memory, add-in PCI and PC cards.
5	Installing and Removing Front Bezel Assembly Items	Gives procedures for installing or removing front bezel items, including display backlight tubes.
6	Initial Operation and Setup	Tells how to start and checkout the system.
7	Windows CE Operating System	Provides an overview of the RAC6182 Windows CE operating system and its native applications and utilities.
8	Keypad Operation	Explains how the RAC6182 keypad functions, and how to use the Keypad configuration application.
9	Display Settings	Explains how to configure the RAC6182 display settings.
10	Touchscreen Calibration	Explains how to calibrate the touchscreen on the RAC6182 Industrial Computer.
11	Hardware Monitor	Explains how to use the Hardware Monitor application to perform hardware diagnostics.
12	Watchdog Timer	Explains how to use the Watchdog Timer application to reset the RAC6182 in case of lockup.
13	Communications Configuration	Explains how to configure the RAC6182 to communicate with a host computer.
14	Managing User Applications	Explains how to install and configure user applications on the RAC6182 computer using Microsoft ActiveSync. Also tells how to move data files to and from the RAC6182 computer, and upgrade the operating system.
15	System Troubleshooting	Explains how to interpret and correct problems with the RAC6182 Industrial Computer.
16	Maintenance	Gives procedures for cleaning the RAC6182 Industrial Computer display.
17	Replacement Parts and Accessories	Describes the replacement parts and accessories that are available for the RAC6182 Industrial Computer, with their corresponding part numbers.



Chapter	Title	Contents
Appendix A	Specifications	Provides physical, electrical, environmental, and functional specifications.
Appendix B	Processor Board Specifications	Provides information on the RAC6182 Industrial Computer processor board.
Appendix C	RAC6182 Compatible Devices	Lists the devices that are compatible with the RAC6182.
Appendix D	RAC6182 Point-to-Point Communications	Describes how to connect the RAC6182 to various devices.

## Manual Conventions

The following conventions are used throughout this manual:

- Bulleted lists such as this one provide information, not procedural steps.
- Numbered lists provide sequential steps or hierarchical information.

## Allen-Bradley Support

Allen-Bradley offers support services worldwide, with over 75 Sales/Support Offices, 512 authorized Distributors and 260 authorized Systems Integrators located throughout the United States alone, plus Allen-Bradley representatives in every major country in the world.

### Local Product Support

Contact your local Allen-Bradley representative for:

- sales and order support
- product technical training
- warranty support
- support service agreements

### Technical Product Assistance

If you need to contact Allen-Bradley for technical assistance, please review the information in the System Troubleshooting chapter first. Then call your local Allen-Bradley representative or contact Allen-Bradley technical support at (440) 646-5800.

For additional product information and a description of the technical services available, visit the Rockwell Automation/Allen-Bradley Internet site at <http://www.ab.com>.



## Computer Features

### Chapter Objectives

This chapter provides an overview of the RAC6182 Industrial Computer for the Windows CE Operating System including:

- available versions
- software
- additional catalog items

### RAC6182 Industrial Computer Versions

The RAC6182 is available with a variety of options:

- Display and operator input
  - 7.7-in. STN display with touchscreen or touchscreen/keypad combination
  - 12.1-in. TFT display with touchscreen or touchscreen/keypad combination
  - No display
- Storage capacity (DiskOnChip)
- Dynamic SDRAM
- ATA Flash PC card
- PCI communication card option (DH+/DH-485)
- Power Input (AC or DC)
- Application software (RSView Studio Machine Edition Runtime)

The RAC6182 Industrial Computer is comprised of a front bezel assembly and computer chassis. The computer chassis is common to all RAC6182 versions, and contains the processor board, power supply, and add-in cards. It is attached to the front bezel assembly with a hinge, so it can be easily opened for internal access.

## **RAC6182 Industrial Computer Packing List**

The RAC6182 Industrial Computer is delivered with the following items:

- Computer with preinstalled Windows CE operating system
- Mounting clips (4)
- Power supply terminal block
- Output relay terminal block
- RAC6182 Applications and Accessories CD-ROM
- Installation Guide (Publication 6182-IN001A-EN-P)
- Microsoft Windows CE License Agreement (Part 41061-185-01(A))
- Software manuals and media for optional bundled software applications.

## **RAC6182 Hardware**

The RAC6182 Computer contains several hardware features designed to make it a flexible computer platform for running industrial applications.

- MIPS 225MHz 32-bit RISC Processor, with hardware floating point coprocessor.
- 32MB-64MB DiskOnChip flash ROM, field upgradeable
- 64MB-256MB Dynamic SDRAM, field upgradeable
- 128KB battery-backed static RAM, for high speed persistent data storage
- Battery-backed real time clock/calendar
- Hardware voltage/temperature monitoring
- Software-based watchdog timer
- Diagnostic Relay Output.

## **RAC6182 Software**

The RAC6182 Industrial Computer is shipped with a product-specific version of the Microsoft Window CE operating system already installed in the product. This is a full installation of Windows CE, complete with the graphical Desktop, file management features, and Internet Explorer application. Additional user application software may also be pre-installed, depending on the RAC6182 version ordered.

The Windows CE operating system is stored in a secured flash ROM location, and cannot be corrupted by any normal user or software applications. Therefore, no Windows CE media is shipped with the RAC6182 product. The RAC6182 operating system can be field upgraded to new versions. For instructions, refer to Chapter 15, Managing User Applications.

New user applications can be field-installed on the RAC6182 Industrial Computer. Chapter 15, Managing User Applications, describes the various methods for installing software applications. The software vendor should also provide instructions for loading the application program.

## **RAC6182 Applications and Accessories CD-ROM**

This CD-ROM delivered with the RAC6182 Industrial Computer contains the Microsoft ActiveSync application software, the RAC6182 User Manual in Adobe Acrobat PDF format, the RAC6182-specific backup files, and some Windows CE application tools.

### **Microsoft ActiveSync**

The RAC6182 Computer supports the Microsoft ActiveSync communication utility. Chapter 15, Managing User Applications, describes how to install and use ActiveSync on a desktop PC. The ActiveSync program is used to manage user applications and data files on the RAC6182 Computer. The connection between RAC6182 and PC can be either an RS232 null modem cable (6189-2NMCBL) or through the Ethernet port.

**Note:** To install Microsoft ActiveSync on a desktop PC for the first time, you must use a null modem serial cable.

An ATA memory card can also be used to transfer files between a PC and the RAC6182 Computer. Chapter 4, Adding/Removing Internal Components, describes how to install and remove PC cards on the RAC6182.

### **RAC6182 User Manual**

An electronic copy of this manual (publication 6182-UM001D-EN-P) is distributed on the RAC6182 Applications and Accessories CD-ROM. The user manual file is in a PDF format. A copy of the Acrobat reader software program is also shipped on this CD-ROM.

### **RAC6182 Backup Files**

The RAC6182-specific operating system, program, and application files are shipped on the CD-ROM. Chapter 15, Managing User Applications, describes the RAC6182-specific files stored on the DiskOnChip flash memory.

**Windows CE Applications**

Some useful Windows CE utility programs are included on the RAC6182 Applications and Accessories CD-ROM. These utilities include network tools to verify Ethernet connections, a registry edit tool, and a scribble application to test the touchscreen. See each application’s online help for details on the program’s features.

**RAC6182 Ordering Information**

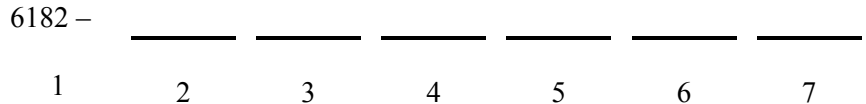

<b>Position #1 - Bulletin Number</b> 6182 = Windows CE Industrial Computer			
<b>Position #2 - Computer Base Unit (Check Factory for Availability)</b> <table border="0" style="width: 100%;"> <tr> <td style="width: 50%; vertical-align: top;"> <b>A</b> = 120/240V ac computer chassis, 32M byte Flash ROM, 1 PCI slot   <b>B</b> = 18-32V dc computer chassis, 32M byte Flash ROM, 1 PCI slot                 </td> <td style="width: 50%; vertical-align: top;"> <b>C</b> = 120/240V ac computer chassis, 64M byte Flash ROM, 1 PCI slot   <b>D</b> = 18-32V dc computer chassis, 64M byte Flash ROM, 1 PCI slot                 </td> </tr> </table>		<b>A</b> = 120/240V ac computer chassis, 32M byte Flash ROM, 1 PCI slot  <b>B</b> = 18-32V dc computer chassis, 32M byte Flash ROM, 1 PCI slot	<b>C</b> = 120/240V ac computer chassis, 64M byte Flash ROM, 1 PCI slot  <b>D</b> = 18-32V dc computer chassis, 64M byte Flash ROM, 1 PCI slot
<b>A</b> = 120/240V ac computer chassis, 32M byte Flash ROM, 1 PCI slot  <b>B</b> = 18-32V dc computer chassis, 32M byte Flash ROM, 1 PCI slot	<b>C</b> = 120/240V ac computer chassis, 64M byte Flash ROM, 1 PCI slot  <b>D</b> = 18-32V dc computer chassis, 64M byte Flash ROM, 1 PCI slot		
<b>Position #3 - Display and Bezel</b> <table border="0" style="width: 100%;"> <tr> <td style="width: 50%; vertical-align: top;"> <b>A</b> = Non-display brick  <b>D</b> = 7.7-inch STN LCD, 640x480, keypad  <b>E</b> = 7.7-inch STN LCD, 640x480, keypad &amp; touchscreen                 </td> <td style="width: 50%; vertical-align: top;"> <b>G</b> = 12.1-inch TFT LCD, 800x600, touchscreen  <b>H</b> = 12.1-inch TFT LCD, 800x600, keypad  <b>I</b> = 12.1-inch TFT LCD, 800x600, keypad &amp; touchscreen                 </td> </tr> </table>		<b>A</b> = Non-display brick <b>D</b> = 7.7-inch STN LCD, 640x480, keypad <b>E</b> = 7.7-inch STN LCD, 640x480, keypad & touchscreen	<b>G</b> = 12.1-inch TFT LCD, 800x600, touchscreen <b>H</b> = 12.1-inch TFT LCD, 800x600, keypad <b>I</b> = 12.1-inch TFT LCD, 800x600, keypad & touchscreen
<b>A</b> = Non-display brick <b>D</b> = 7.7-inch STN LCD, 640x480, keypad <b>E</b> = 7.7-inch STN LCD, 640x480, keypad & touchscreen	<b>G</b> = 12.1-inch TFT LCD, 800x600, touchscreen <b>H</b> = 12.1-inch TFT LCD, 800x600, keypad <b>I</b> = 12.1-inch TFT LCD, 800x600, keypad & touchscreen		
<b>Position #4 - Random Access Memory Size (RAM)</b> <table border="0" style="width: 100%;"> <tr> <td style="width: 50%; vertical-align: top;"> <b>A</b> = 32M byte DIMM RAM (Not available with RSView ME v3.0)  <b>B</b> = 64M byte DIMM RAM                 </td> <td style="width: 50%; vertical-align: top;"> <b>C</b> = 128M byte DIMM RAM  <b>D</b> = 256M byte DIMM RAM                 </td> </tr> </table>		<b>A</b> = 32M byte DIMM RAM (Not available with RSView ME v3.0) <b>B</b> = 64M byte DIMM RAM	<b>C</b> = 128M byte DIMM RAM <b>D</b> = 256M byte DIMM RAM
<b>A</b> = 32M byte DIMM RAM (Not available with RSView ME v3.0) <b>B</b> = 64M byte DIMM RAM	<b>C</b> = 128M byte DIMM RAM <b>D</b> = 256M byte DIMM RAM		
<b>Position #5 - PCI Option Card</b> <table border="0" style="width: 100%;"> <tr> <td style="width: 50%; vertical-align: top;"> <b>A</b> = 1784-PKTX PCI card (DH+ and DH-485 networks)                 </td> <td style="width: 50%; vertical-align: top;"> <b>Z</b> = None                 </td> </tr> </table>		<b>A</b> = 1784-PKTX PCI card (DH+ and DH-485 networks)	<b>Z</b> = None
<b>A</b> = 1784-PKTX PCI card (DH+ and DH-485 networks)	<b>Z</b> = None		
<b>Position #6 - PC Option Card</b> <table border="0" style="width: 100%;"> <tr> <td style="width: 50%; vertical-align: top;"> <b>A</b> = 32MB ATA Flash Memory Card  <b>B</b> = 40+MB ATA Flash Memory Card                 </td> <td style="width: 50%; vertical-align: top;"> <b>Z</b> = None                 </td> </tr> </table>		<b>A</b> = 32MB ATA Flash Memory Card <b>B</b> = 40+MB ATA Flash Memory Card	<b>Z</b> = None
<b>A</b> = 32MB ATA Flash Memory Card <b>B</b> = 40+MB ATA Flash Memory Card	<b>Z</b> = None		
<b>Position #7 - Operating System &amp; Application Software</b> <table border="0" style="width: 100%;"> <tr> <td style="width: 50%; vertical-align: top;"> <b>A</b> = Windows CE 2.12, RSView Machine Edition v1.0 (obsolete)  <b>B</b> = Windows CE 3.0, RSView Machine Edition v1.5 (obsolete)  <b>C</b> = Windows CE 3.0, RSView Machine Edition v2.0/v2.1 (obsolete)  <b>D</b> = Windows CE 3.0, RSView Machine Edition v3.0                 </td> <td style="width: 50%; vertical-align: top;"> <b>Y</b> = Windows CE 3.0, no application  <b>Z</b> = Windows CE 2.12, no application (obsolete)                 </td> </tr> </table>		<b>A</b> = Windows CE 2.12, RSView Machine Edition v1.0 (obsolete) <b>B</b> = Windows CE 3.0, RSView Machine Edition v1.5 (obsolete) <b>C</b> = Windows CE 3.0, RSView Machine Edition v2.0/v2.1 (obsolete) <b>D</b> = Windows CE 3.0, RSView Machine Edition v3.0	<b>Y</b> = Windows CE 3.0, no application <b>Z</b> = Windows CE 2.12, no application (obsolete)
<b>A</b> = Windows CE 2.12, RSView Machine Edition v1.0 (obsolete) <b>B</b> = Windows CE 3.0, RSView Machine Edition v1.5 (obsolete) <b>C</b> = Windows CE 3.0, RSView Machine Edition v2.0/v2.1 (obsolete) <b>D</b> = Windows CE 3.0, RSView Machine Edition v3.0	<b>Y</b> = Windows CE 3.0, no application <b>Z</b> = Windows CE 2.12, no application (obsolete)		

### Features of the RAC6182 Industrial Computer

The following illustrations show the major features and controls of the display versions of the RAC6182 Industrial Computer.

### RAC6182 Computer – 7.7 in. Version with Keypad

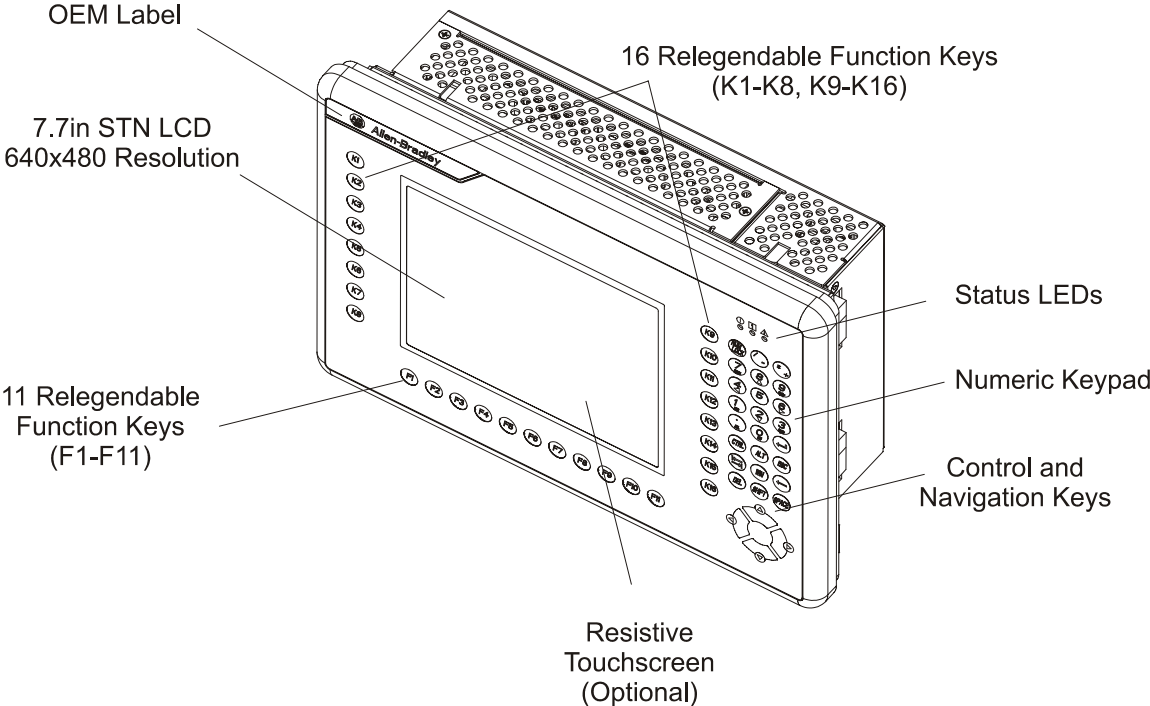

### RAC6182 Computer – 12.1 in. Version with Keypad

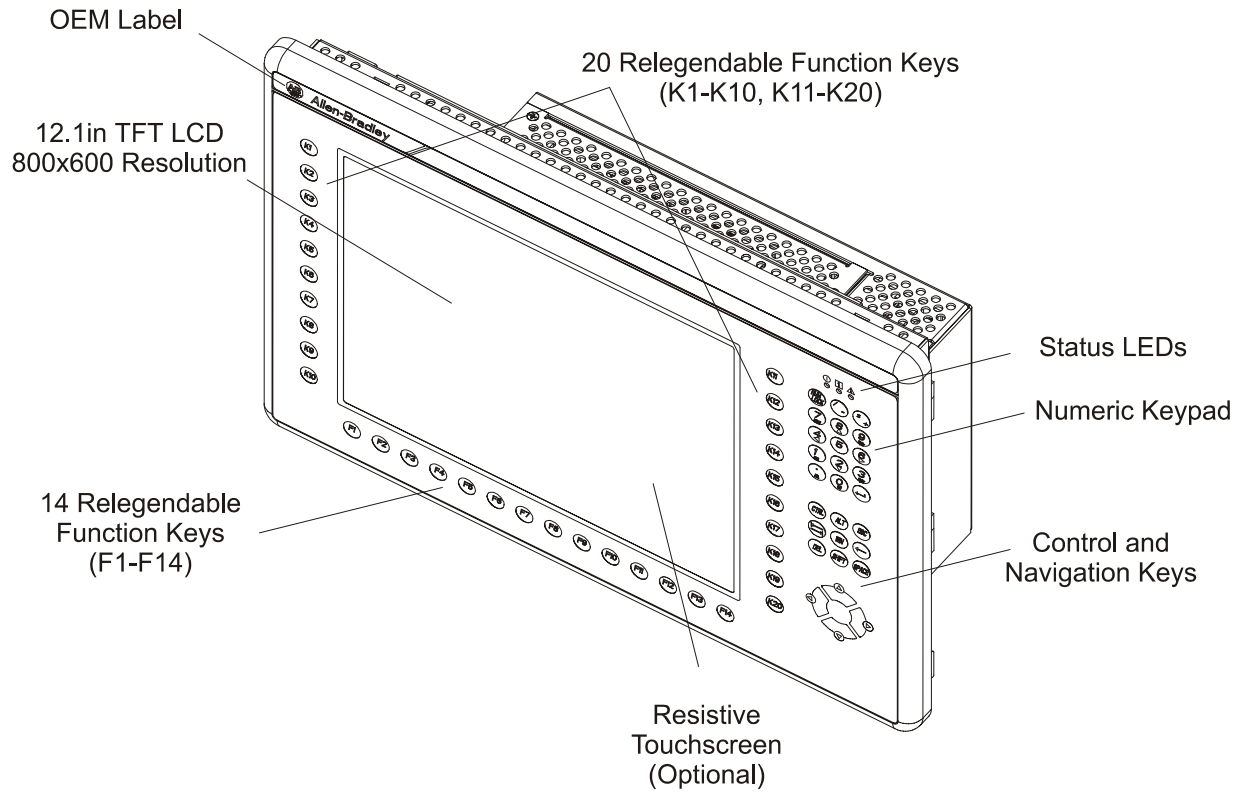

### RAC6182 Computer – 12.1 in. Version with Touchscreen

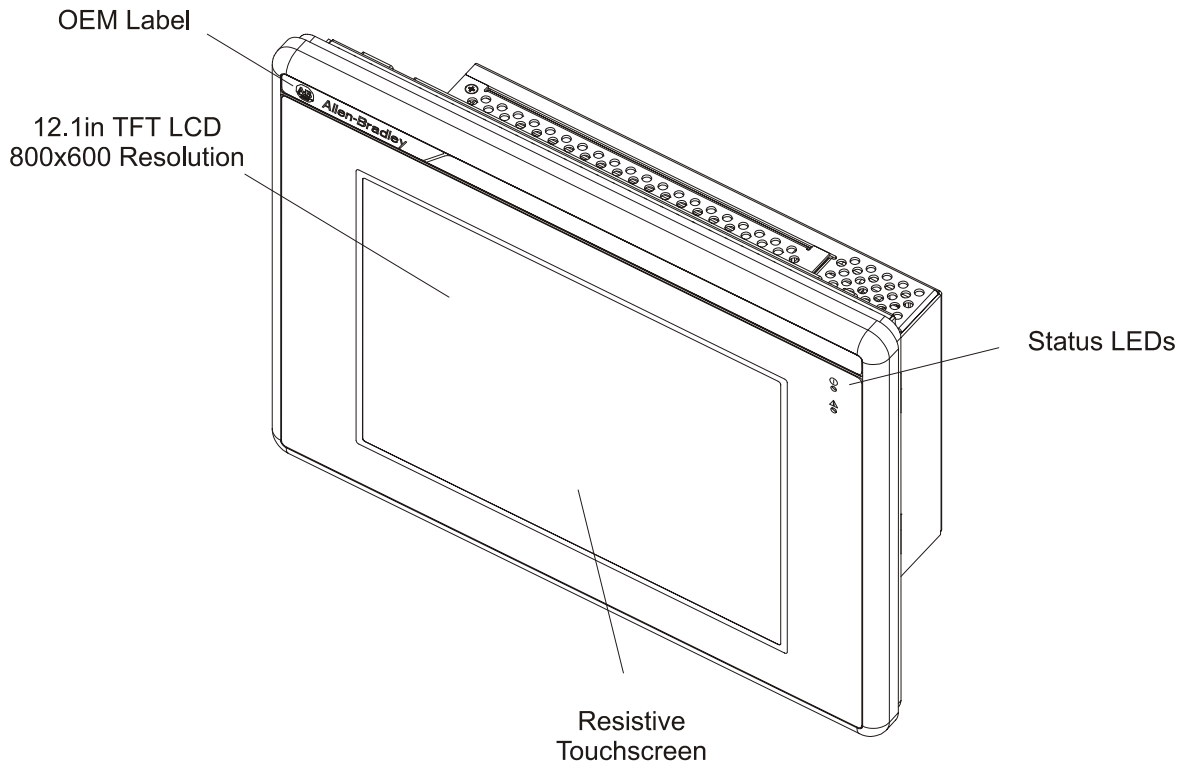



### RAC6182 Computer Common Chassis

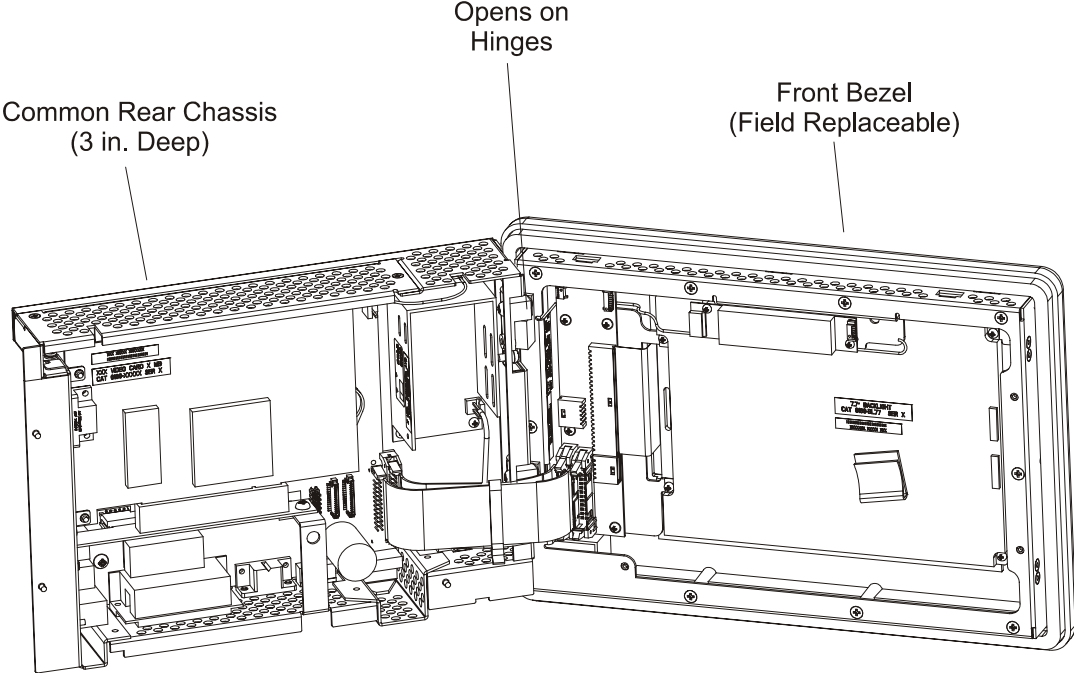

### RAC6182 Industrial Computer Connectors

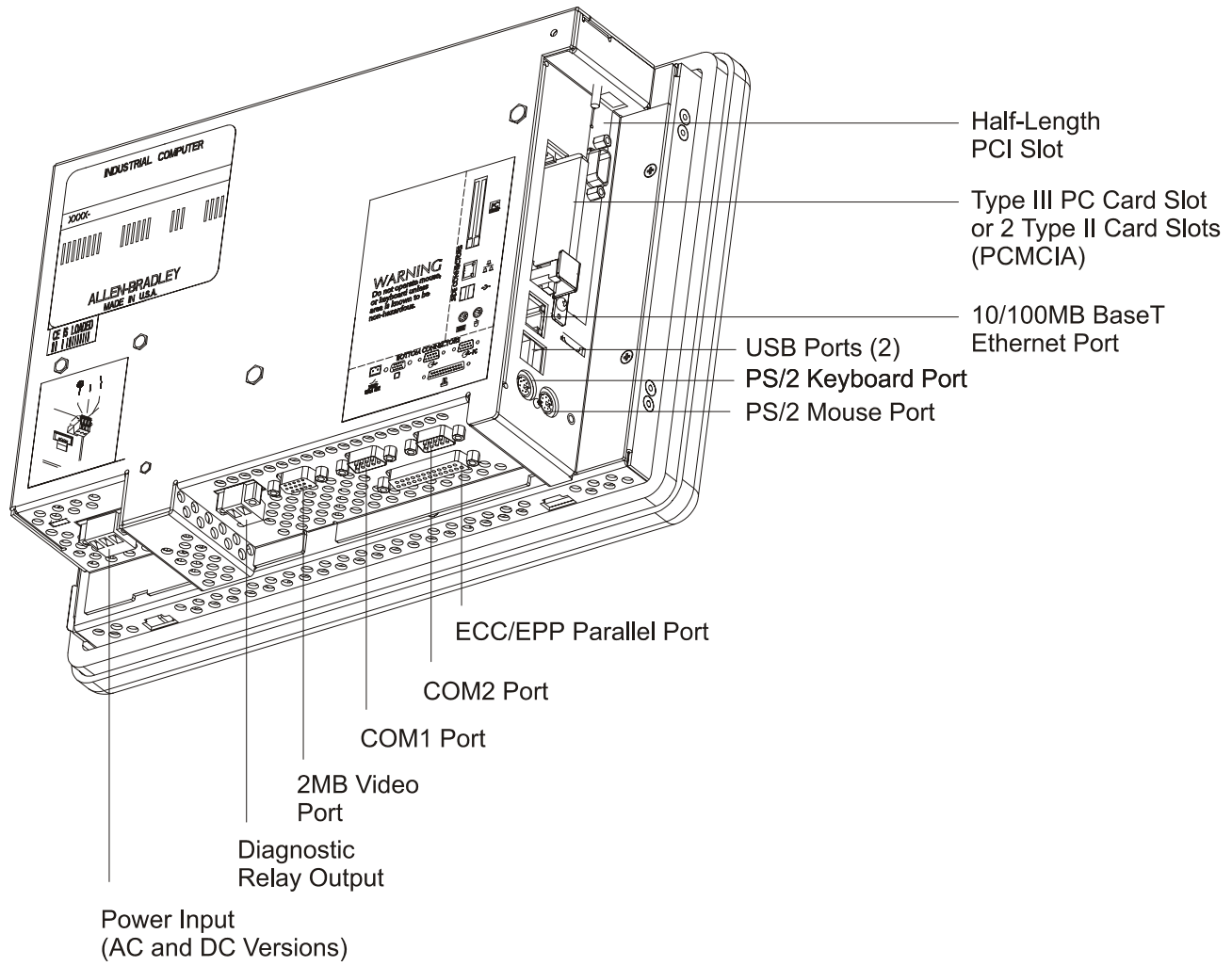



**WARNING: EXPLOSION HAZARD!** Substitution of components may impair suitability for Class I, Div 2 hazardous locations.

## LED Indicators

The following table shows the LED indicators on the RAC6182 Industrial Computer.

**Table A**  
**LED Indicators (Display Versions Only)**

Indicator	Position	Color	Indicates
	Right	Red	<p>Diagnostics. Indicates that one of the following conditions exists when lit:</p> <p>Overtemperature. Temperature inside the RAC6182 Industrial Computer enclosure is above defined threshold.</p> <p>Voltage. Voltages not within specification.</p> <p>Refer to Chapter 16, System Troubleshooting, for information on resolving diagnostic conditions.</p>
	Center	Green	Numlock key activated when lit
	Left	Green	Power On when lit

**Note:** The LEDs toggle on and off during power up.



## Installation

### Chapter Objectives

This chapter describes installation of the RAC6182 Industrial Computer for the Windows CE Operating System, including how to install the RAC6182 Industrial Computer in a panel using mounting clips.

### European Union Compliance

The RAC6182 Industrial Computer meets the European Union Directive requirements when installed within the European Union or EEA regions and has the CE mark. A copy of the Declaration of Conformity is available at the Rockwell Automation/Allen-Bradley Internet site: [www.ab.com](http://www.ab.com)

### Environmental Considerations

Mount the RAC6182 Industrial Computer in a panel or enclosure to protect the internal circuitry. Versions with a gasketed bezel meet NEMA Type 1, 12, 13 and 4X (Indoor use) and IEC IP54, IP65 only when properly mounted in a panel or enclosure having an equivalent rating. The non-display version does not have a gasket and has a NEMA Type 1 and IEC IP2X rating.

Allow enough room within the enclosure for adequate ventilation. Also consider heat produced by other devices in the enclosure. The ambient temperature around the RAC6182 Industrial Computer must be maintained between 0° and 50°C (32° to 122° F). The RAC6182 Industrial Computer is intended for use in Pollution Degree 2 environments.

Make sure you provide provisions for accessing the top, bottom, and side panels of the RAC6182 Industrial Computer to install/remove components and to access the connectors.

### Mounting Hardware

Versions of the RAC6182 Industrial Computer with a display are shipped with the following mounting hardware:

**Table B**  
**Mounting Hardware**

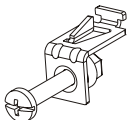
Item	Description	Quantity	Use For
	Mounting Clips	4 Clips	Panel or enclosure mounting

The following replacement clips can be ordered from Rockwell Automation:

Part Number	Description	Quantity	Use For
6189-2MTGKIT	Mounting clips	Package of 4 clips	Replacement item

## Tools Required

In addition to the tools required to make the cutout, you will need a #2 Phillips-head screwdriver and a torque wrench.

## Mounting Clearances

Allow adequate space for mounting, air flow, and maintenance. The figure below shows recommended minimum clearances to other components within the rack or enclosure.



**ATTENTION:** The RAC6182 Industrial Computer should not be operated within a confined space of the dimensions shown below unless adequate ventilation or other cooling methods are used to lower the air temperature within the enclosure.

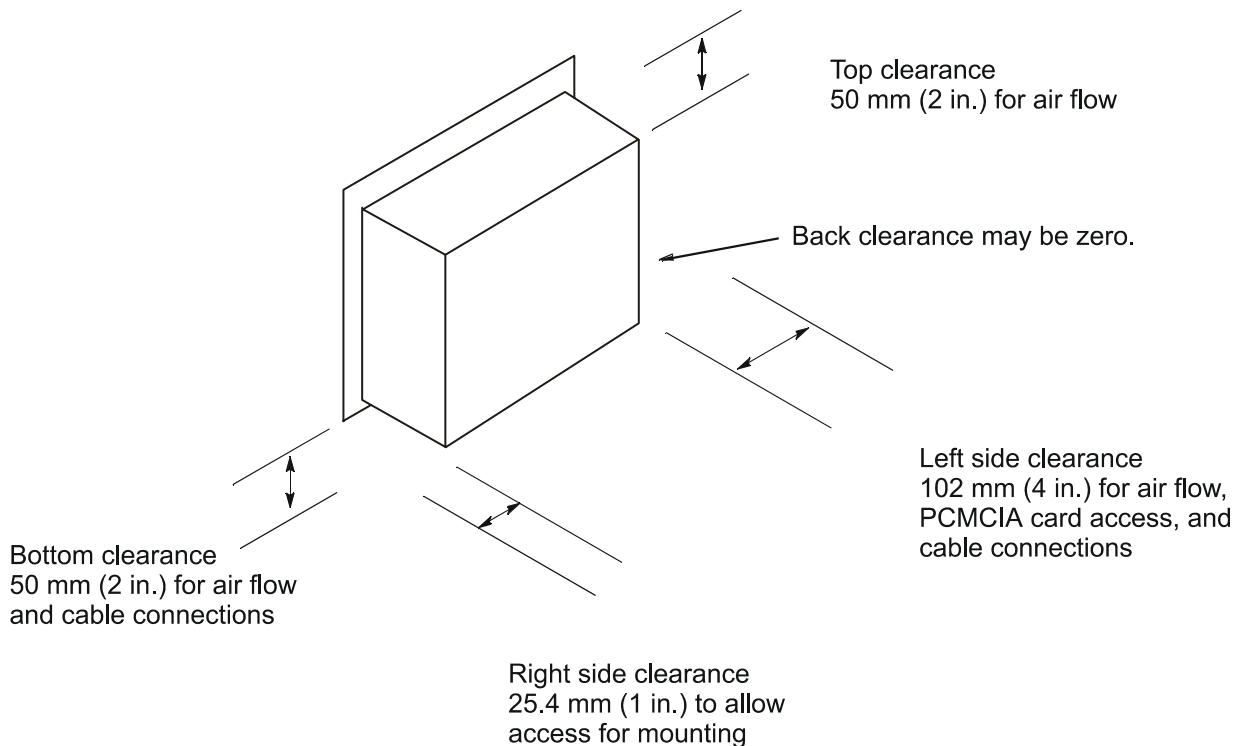

## Mounting Dimensions

The following figures show the mounting dimensions for the RAC6182 Industrial Computer.

**Note:** Measurements in these figures are expressed in millimeters [inches].

### 7.7 in. Version with Keypad

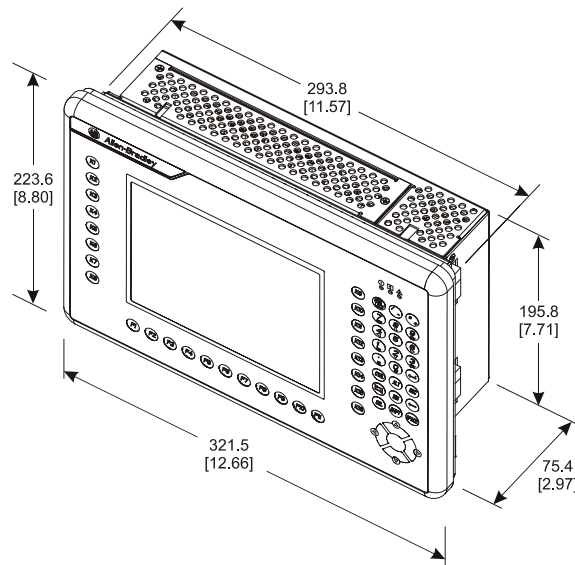

### 12.1 in. Version with Keypad

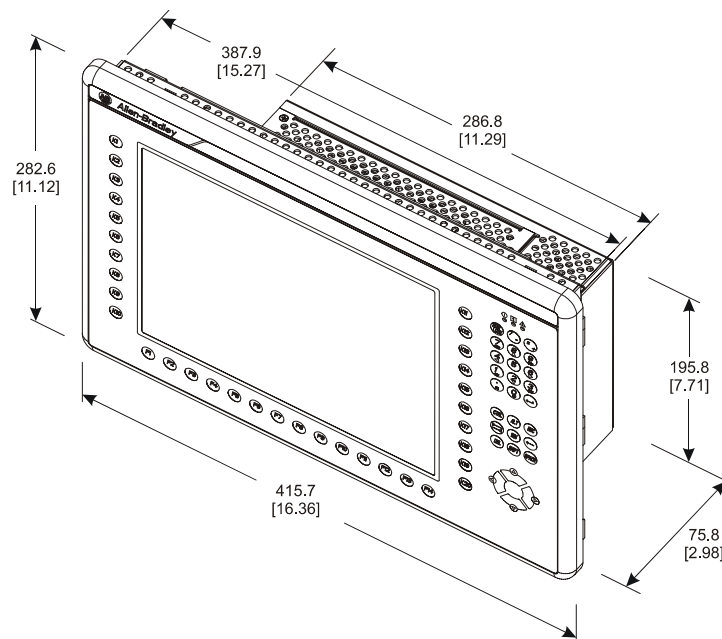

### 12.1 in. Version with Touchscreen

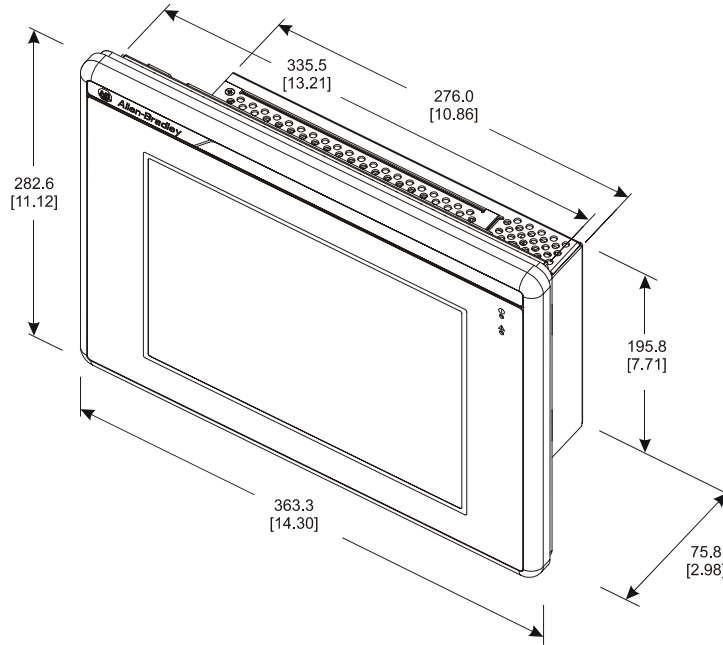

### Non-Display Version

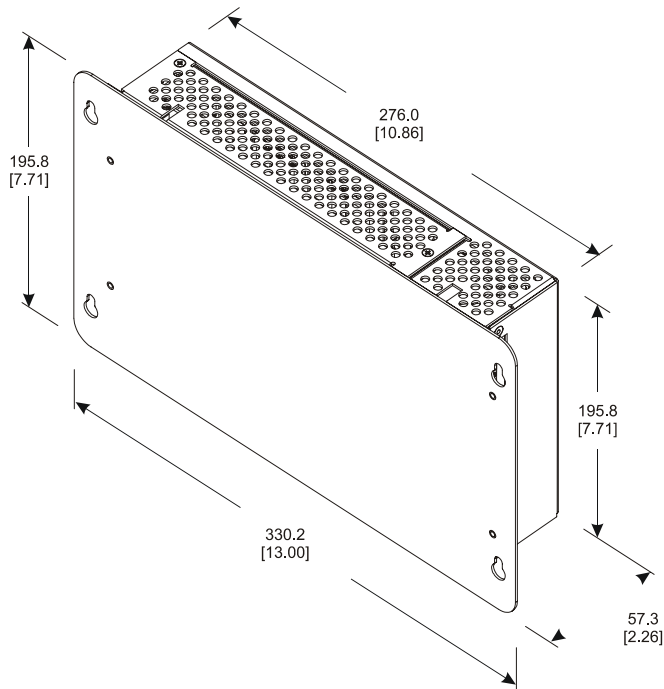



## Mounting Cutouts

The following figure provides the dimensions for making the panel or enclosure cutout for the RAC6182 Industrial Computer.

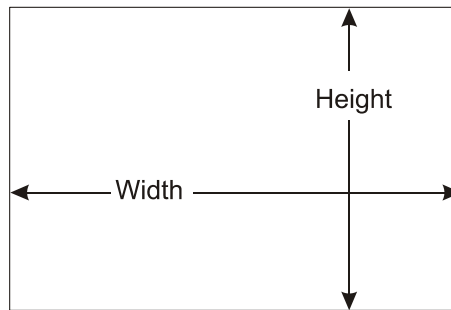

**Table C**  
**Mounting Cutout Sizes**

Display Size	Height	Width
7.7 in. version with keypad	197.8 [7.79]	295.8 [11.65]
12.1 in. version with touchscreen	256.8 [10.11]	337.6 [13.29]
12.1 in. version with keypad	256.8 [10.11]	389.9 [15.35]

## Panel Mounting

To install the RAC6182 Industrial Computer in a panel:



**ATTENTION:** Disconnect all electrical power from the panel before making cutout.

Make sure the area around the panel cutout is clear.

Take precautions so that metal cuttings do not enter any components that are already installed in the panel.

Failure to follow these warnings may result in personal injury or damage to the panel components.

### To install the RAC6182 Industrial Computer in a panel:

1. Cut an opening in the panel using the panel cutout dimensions provided on Page 2-5.
2. Make sure the RAC6182 Industrial Computer sealing gasket is properly positioned on the terminal. This gasket forms a compression type seal. Do not use sealing compounds.
3. Place the RAC6182 Industrial Computer in the panel cutout.

4. Install the mounting clips. The mounting clips slide into the slots on the top and bottom of the RAC6182 Industrial Computer.

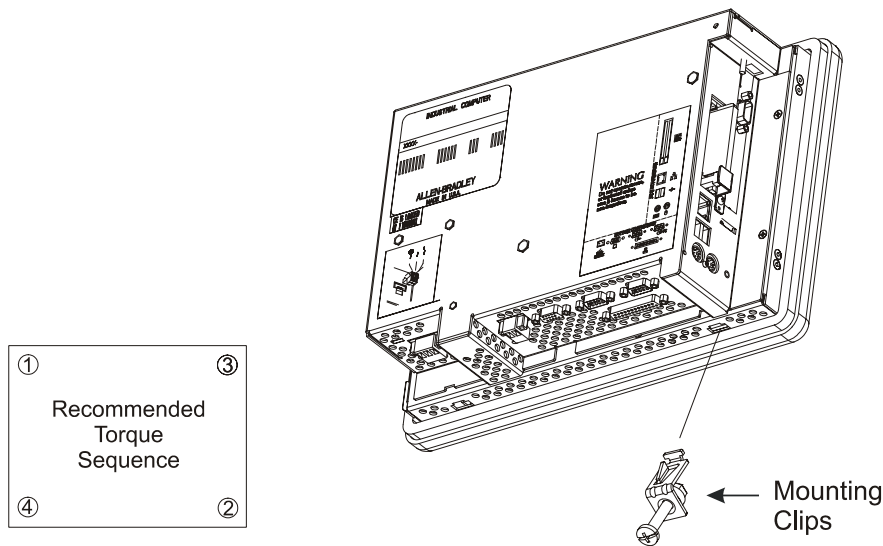

5. Gradually tighten the clips one at a time around the bezel using the specified sequence. Repeat this process at least three times until the clips are hand-tight and the gasket is compressed uniformly against the panel.
6. Tighten mounting clips to a torque of 10 in–lbs (1.1 N•m) in the sequence shown above. **Do not over-tighten.**



**ATTENTION:** Tighten mounting clips to a torque of 10 in–lbs (1.1 N•m) to provide a proper seal and prevent damage to the RAC6182 Industrial Computer. Allen–Bradley assumes no responsibility for water or chemical damage to the terminal or other equipment within the enclosure because of improper installation.

## Power Connections

A three-contact removable terminal block is used to connect power to the RAC6182 Industrial Computer. The RAC6182 Industrial Computer AC version accepts 120/240V AC. The AC power supply is autoranging. The DC version accepts 18-32V DC. The removable terminal blocks are different on the AC and DC versions and cannot be interchanged.



**ATTENTION:** The power supply must be connected to an earth ground. Failure to follow this warning could result in severe electrical shock.

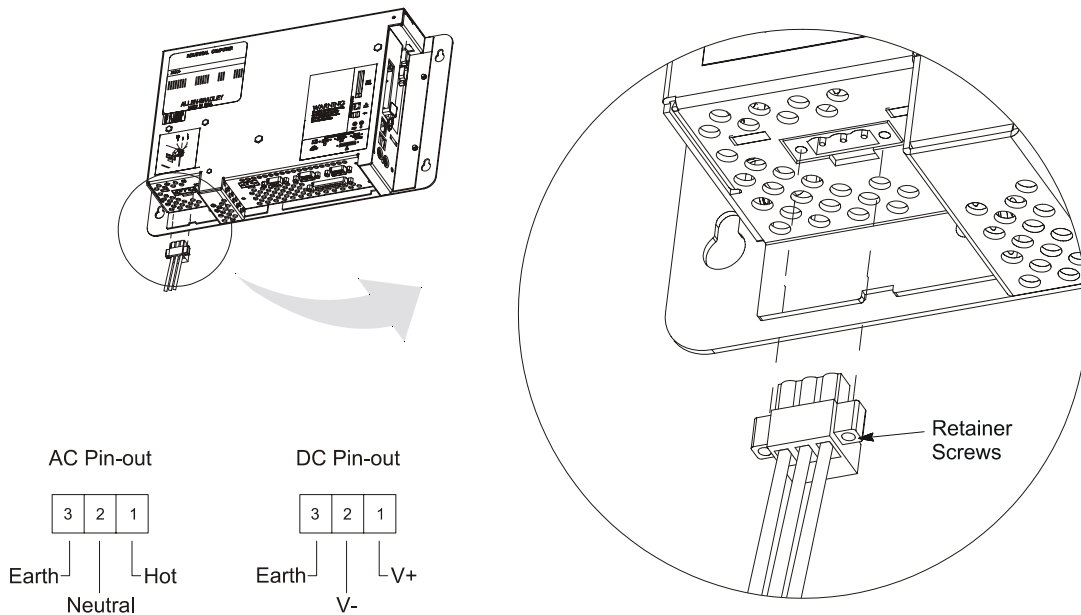

**ATTENTION:** Some 1784 communication cards have a connector like the one used for the RAC6182 power connector. **Do not plug power into connectors on these cards.**

The terminal block is equipped with two retainer screws to prevent accidental interruption of power to the RAC6182 Industrial Computer. Tighten the screws on the AC version to a torque of 5 in-lbs (0.56 N•m). Tighten the screws on the DC version to a torque of 2.5 in-lbs (0.28 N•m).



**WARNING: EXPLOSION HAZARD!** Do not connect or disconnect equipment unless power has been switched off or the area is known to be non-hazardous.

A 3-part kit with the terminal blocks can be ordered from Rockwell Automation:

Part Number	Description
6189-2CONN	120/240VAC Unit terminal block (qty 1) 24VDC Unit terminal block (qty 1) Relay output terminal block (qty 1)

## Relay Output

The RAC6182 Industrial Computer has a relay output. This output is a normally-open hard contact relay rated for 24VDC, 500mA. A two-contact removable terminal block is used to connect to the relay output.

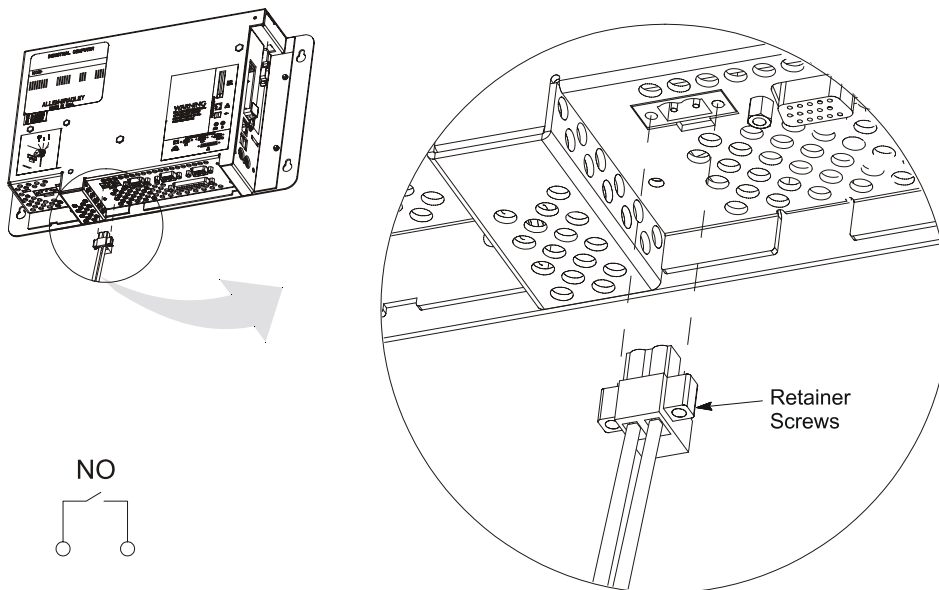

The terminal block is equipped with two retainer screws to prevent accidental disconnection. Tighten these screws to a torque of 5 in-lbs (0.56 N•m).

A 3-part kit with the terminal blocks can be ordered from Rockwell Automation:

Part Number	Description
6189-2CONN	Relay output terminal block (qty 1) 120/240VAC Unit terminal block (qty 1) 24VDC Unit terminal block (qty 1)

## Connecting External Devices

### Chapter Objectives

This chapter describes how to connect a variety of external devices to the RAC6182 Computer. This chapter's topics include:

- USB devices
- PS/2 keyboard and mouse
- Ethernet network connection (RJ45)
- Serial devices
- Parallel devices
- External video monitors
- Relay output

### Safety Precautions

Make sure you disconnect all power to the RAC6182 Industrial Computer before performing any of the operations described in this chapter.



**ATTENTION:** Disconnect all power from the RAC6182 Industrial Computer and external devices before making any connections. Failure to disconnect power could result in damage to the RAC6182 Industrial Computer and/or external device.

---

As with all electronic devices, internal RAC6182 Industrial Computer components may be damaged by Electrostatic Discharge (ESD). Do not touch connector pins when attaching external cables. Touch the metal chassis to discharge yourself before connecting external cables.

## Connecting USB Devices

The RAC6182 Computer has two USB ports. The Windows CE operating system currently only supports standard USB keyboard and mouse devices with its native device drivers. A vendor-specific Windows CE driver will be required for all other USB devices.

The USB device can plug into either of the two side panel USB ports as shown below. While the USB interface is designed to be connected and disconnected under power, the Windows CE operating system will not automatically recognize any changes made under power.

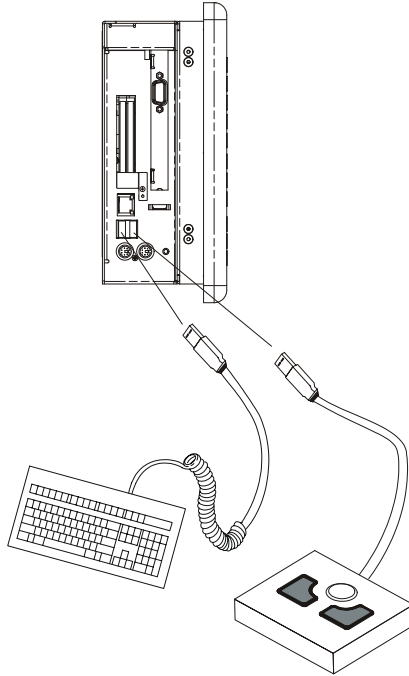
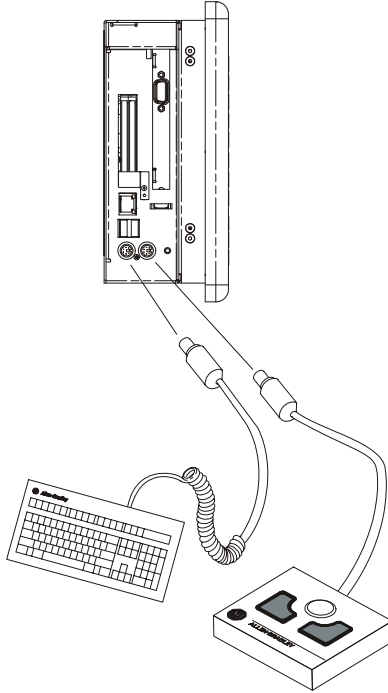

**Table D**  
**USB Stacked Connector Pin-Out**

PIN	Signal
1	USB0VCC (Switched FET current protected)
2	USB0D-
3	USB0D+
4	USB0GND
5	USB1VCC (Switched FET current protected)
6	USB1D-
7	USB1D+
8	USB1GND
9	SHLDGND
10	SHLDGND

## Connecting PS/2 Keyboard and Mouse

The mouse and keyboard plug into the side panel mouse and keyboard ports as shown below. Any standard PS/2 keyboard and mouse devices can be used. Both devices must be connected before power-up to be recognized by the Windows CE operating system.



**Table E**  
**PS/2 Port Connector Pin-Out**

PIN	Signal
1	KBDATA
2	Not connected
3	GND
4	VCC
5	KBCLK
6	Not connected
7	MSDATA
8	Not connected
9	GND
10	VCC
11	MSCLK
12	Not connected
13	Shield Ground
14	Shield Ground
15	Shield Ground
16	Shield Ground
17	Shield Ground

## Connecting to an Ethernet Network

The RAC6182 Industrial Computer accommodates CAT5 twisted pair Ethernet cabling with RJ45 connectors to support 10 Mbps and 100 Mbps network data transfer rates. Shielded cabling is required to maintain EMI compliance.

A ferrite collar is included with the RAC6182 and is intended for use with an Ethernet cable connected to a RAC6182. Install the collar for suppression of electromagnetic emissions and interference. The collar is required for compliance with the European EMC directive.

To be effective, the ferrite collar must be placed on the cable where the cable exits the RAC6182.

### To install the ferrite collar:

1. Fold the collar so that it encircles the cable.
2. Press the plastic housing until the collar snaps together.
3. Check that the collar is fully latched.

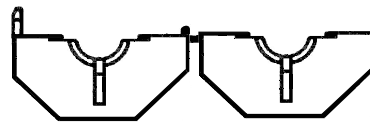

Open Ferrite Collar  
(Side View)

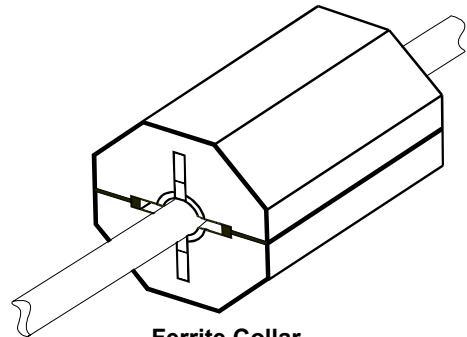

Ferrite Collar  
Folded Around Cable

**Note:** For information on connecting the RAC6182 Industrial Computer to a host PC using the Ethernet connection, refer to Chapter 14, Communications Configuration.



**Important:** Performance degradation of your Ethernet communications is likely to result if the unit or cables are subjected to extreme radiated or conducted high-frequency noise. It is the user's responsibility to properly route cables and condition input power in order to improve communication reliability.

Proper cable routing and power conditioning is required to ensure reliable Ethernet communications in industrial environments. Rockwell Automation recommends that all Ethernet cabling be routed through dedicated metal conduits. Installing ferrite bead filters at cable ends may also improve reliability.

**Table F**  
**RJ45 Ethernet Connector Pin-Out**

<b>PIN</b>	<b>Signal</b>
1	LANTX+
2	LANTX-
3	LANRX+
4	LANGND
5	LANGND
6	LANRX-
7	LANTXDBN
8	LANRXDAN
9	LANSHLD1
10	LANSHLD2

## Connecting Serial Devices

The RAC6182 Computer has two serial ports – COM1 and COM2, both with DB9 male connectors.

The COM1 port supports RS232, RS422, and RS485 physical signals. The COM1 physical signals are software-selectable.

The COM2 port supports only RS232 physical signals. The COM2 port is used to connect to a host PC using ActiveSync.

**Note:** You must use a null modem cable (6189-2NMCBL) to connect the COM2 port to a host PC. For information on the null modem cable, refer to Appendix D, RAC6182 Point-to-Point Communications.

**Note:** For information on connecting the RAC6182 Industrial Computer to a host PC using the serial port, refer to Chapter 14, Communications Configuration.

**Table G**  
**DB9 Male Connector Pin-Out**

PIN	RS232 Signal (COM1 and COM2)	RS422/RS485 Signal (COM1 Only)
1	DCD	TXD(+)
2	RXD	TXD(-)
3	TXD	RXD(+)
4	DTR	RXD(-)
5	SGND	SGND
6	DSR	DH485 TXENBL
7	RTS	Not connected
8	CTS	Not connected
9	RI	Not connected

## Connecting Parallel Devices

The RAC6182 Computer has an ECP/EPP compatible parallel printer port with a DB25 female connector. This port can be connected to a parallel printer. The RAC6182 Windows CE operating system provides a PCL3 printer driver. If other printers are to be used, you must provide the associated Windows CE printer driver if available.

**Table H**  
**Parallel Port DB25 Female Connector Pin-Out**

PIN	Signal
1	STROBE#
2	PD0
3	PD1
4	PD2
5	PD3
6	PD4
7	PD5
8	PD6
9	PD7
10	ACK#
11	BUSY
12	ERROR
13	SELECT
14	AUTOFD#
15	FAULT#
16	INIT#
17	SLCT IN#
18	GROUND
19	GROUND
20	GROUND
21	GROUND
22	GROUND
23	GROUND
24	GROUND
25	GROUND

## Connecting an External Video Monitor

The RAC6182 Computer has an external HD15 video connector. It can drive an external monitor with VGA, SVGA or XGA analog video signals.

**Note:** For information on setting the video resolution and refresh rate for an external monitor, refer to Chapter 10, Display Settings.

**Table I**  
**HD15 Video Connector Pin-Out**

PIN	Signal
1	RED
2	GREEN
3	BLUE
4	Not connected
5	GND
6	GND
7	GND
8	GND
9	Not connected
10	GND
11	Not connected
12	DDC_DATA (pull-up)
13	HSYNC
14	VSYNC
15	DDC_CLK (pull-up)
16	Shield ground
17	SLCT IN#

## Connecting to Relay Output

The RAC6182 Industrial Computer has a relay output. This output is a normally-open hard contact relay rated for 24VDC, 500mA. A two-contact removable terminal block is used to connect to the relay output.

**Note:** For instructions on connecting the relay output, refer to Page 2-8.

The relay output can be used to drive a variety of peripheral signaling devices such as a tower annunciator light or an audible alarm or buzzer. The output can also be connected to an embedded control system to signal a RAC6182-generated event.



## Adding/Removing Internal Components

### Chapter Objectives

This chapter describes how to open the chassis of the RAC6182 Industrial Computer and remove or install:

- PC add-in cards (PCMCIA)
- PCI add-in card
- RAM
- DiskOnChip flash ROM

### Safety Precautions

The RAC6182 Industrial Computer contains line voltages. Make sure you disconnect all power to the RAC6182 Industrial Computer before removing covers or access screws.



**ATTENTION:** Disconnect all power from the RAC6182 Industrial Computer before removing components. Failure to disconnect power could result in severe electrical shock or damage to the RAC6182 Industrial Computer.

---

Internal RAC6182 Industrial Computer components may be damaged by Electrostatic Discharge (ESD). Make sure you wear a grounding strap whenever handling circuit boards, memory modules or other internal components.



**ATTENTION:** Wear a wrist strap (well grounded) and perform work in a static safe environment.

Electrostatic discharge can damage the RAC6182 Industrial Computer and components.

---

## Thermal Considerations for Add-In Cards

The RAC6182 Industrial Computer accommodates one PCI compatible add-in card. Due to thermal considerations with the unit, total add-in power is limited to 7W of power dissipation (within the product enclosure).

**Table J**  
**PCI Card Current Limits**

Voltage	Current Limit at Specified Voltage
5V	1.0A
3.3V	0.1A
12V	0.1A
-12V	-0.05A

## Opening or Removing the Chassis

This section shows how to open and close the RAC6182 chassis to access internal components.



**ATTENTION:** Review safety precautions on Page 4-1 before proceeding. Failure to follow proper safety procedures could result in severe electrical shock or damage to the RAC6182 Industrial Computer.

### To open the chassis (display versions):

1. Disconnect power from the RAC6182 Industrial Computer.
2. Remove the 3 screws securing the chassis to the front bezel.

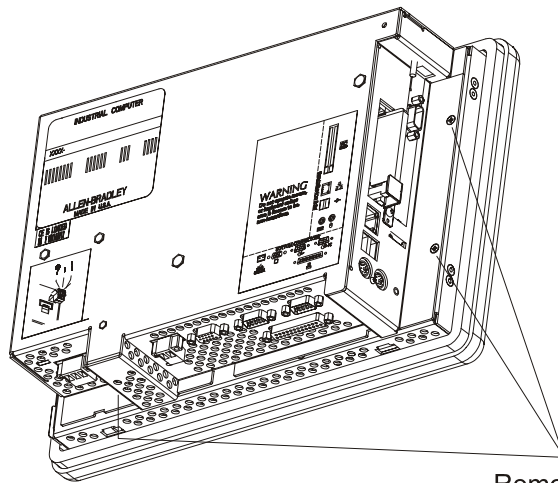

Remove 3 Screws to  
Open Chassis

3. Open the chassis away from the front bezel. Be careful not to stress or disconnect the internal cables running between the chassis and front bezel.



**To remove the chassis (display versions):**

1. To remove the chassis completely from the front bezel, carefully disconnect the internal cables from the chassis printed circuit board.
2. Remove the set-screw in the hinge, and lift the back chassis off the front bezel hinges.

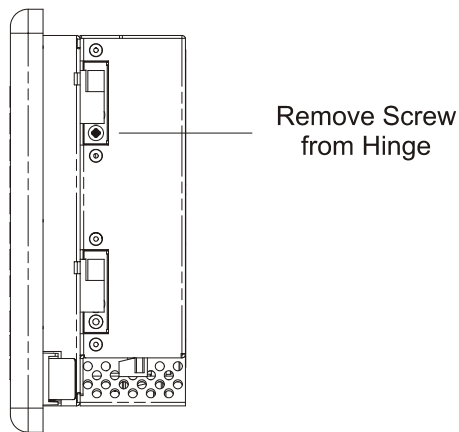
**To replace the chassis (display version):**

1. To replace the chassis, remount the chassis onto the front bezel hinges and reinstall the hinge set-screw. Reconnect the cables to the chassis printed circuit board.
2. To close the chassis, slowly hinge the chassis back against the front bezel. Be careful not to pinch the internal cables.
3. Reinstall the 3 screws to secure the chassis to the front bezel. Tighten the screws to a torque of 6 - 8 in-lbs (0.7 - 0.9 N•m).

**Important:** For a replacement chassis assembly, order the RAC6182 non-display unit with the required options (6182-xAxxxx).

**To open the chassis (non-display versions):**

1. Disconnect power from the RAC6182 Industrial Computer.
2. Remove the 4 nuts securing the chassis to the front plate.

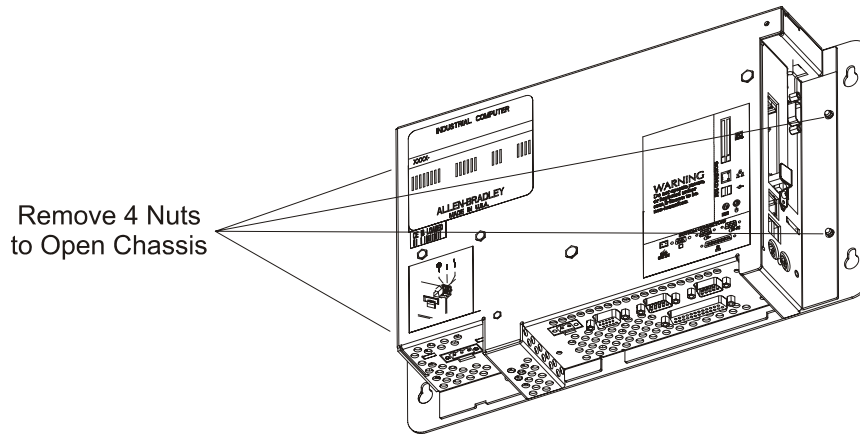

3. To close the chassis, reinstall the 4 nuts to secure the chassis to the front plate. Tighten the nuts to 6 - 8 in-lbs (0.7 - 0.9 N•m).

## Adding/Removing PC Cards (PCMCIA)

One Type III PC card or two Type II PC cards (PCMCIA) may be installed in the RAC6182 computer. While the RAC6182 PCMCIA slots are electrically compatible with any standard PC card, special Windows CE drivers are required to make the PC card function on the RAC6182 computer. Refer to the application program to make sure it supports the desired PC card.

The following memory PC cards can be ordered from Rockwell Automation:

Part Number	Description
6189-ATA32	32MB ATA flash PC card
6189-ATA64	64MB ATA flash PC card



**ATTENTION:** Review safety precautions on Page 4-1 before proceeding.

Failure to follow proper safety procedures could result in severe electrical shock or damage to the RAC6182 Industrial Computer.



**ATTENTION:** PC cards may be sensitive to ESD and require careful handling. Hold cards only by the edges do not touch connectors. After removing a card, place the PC card in an anti-static wrapper.

**To install a PC card:**

1. Locate the PC card slots on the side of the RAC6182.
2. Loosen the screw on the PC card retainer bracket covering the PC card slot, if necessary.
3. Insert the PC card into the desired slot. Make sure the PC card is fully seated and the slot ejector is out. Up to 2 Type II cards can be installed in the RAC6182.

**Note:** Most PC cards are hot-swappable on the RAC6182. You do not need to turn off power to the unit. Install one PC card at a time to ensure correct installation.

4. Position the PC card retainer over the PC card and slot ejector and tighten the screw. Tighten the screw to a torque of 6 - 8 in-lbs (0.7 - 0.9 N•m).
5. Load the associated software and drivers for the card, if needed. The Windows CE operating system automatically recognizes compatible memory cards.
6. Follow instructions in the associated PC card user manual to make any required external cable connections.

**To remove a PC card:**

1. Locate the PC card slots on the side of the RAC6182.

**Note:** Most PC cards are hot-swappable on the RAC6182. You do not need to turn off power to remove the card. Remove one PC card at a time to ensure correct removal.

2. Loosen the screw on the PC card retainer bracket and rotate the bracket to remove the PC card.
3. Remove any external cables attached to the PC card.
4. Press the slot ejector to unseat the PC card from the slot. Remove the PC card and store in an anti-static wrapper.
5. Position the PC card retainer over any remaining PC card and slot ejector and tighten the screw. Tighten the screw to a torque of 6 - 8 in-lbs (0.7 - 0.9 N•m).

## Adding/Removing a PCI Card

One PCI card can be installed in the RAC6182 computer. While the RAC6182 expansion slot is electrically compatible with any standard half-length PCI card, special Windows CE drivers are required to make a PCI card function on the RAC6182 computer. Refer to the application program to make sure it supports the desired PCI card.

The following PCI cards are available as factory-installed RAC6182 options, and are supported by Rockwell Software's RSView Machine Edition application version 1.0.

Part Number	Description
1784-PKTX	Single-channel DH+/RIO/DH485 network card



**ATTENTION:** Review safety precautions and information on thermal considerations for add-in cards on Page 4-2 before proceeding.

Failure to follow proper safety procedures could result in severe electrical shock or damage to the RAC6182 Industrial Computer.



**ATTENTION:** Add-in cards may be sensitive to ESD and require careful handling. Hold cards only by the edges--do not touch connectors. After removing a card, place the card on a flat static free surface, component side up. Do not slide the card over any surface.

### To install a PCI card:

To complete this procedure, you will need a #1 and a #2 Phillips head screwdriver.

1. Turn off power to the RAC6182.
2. Remove the 2 screws securing the top cover to the chassis.
3. Remove the screw securing the slot cover and remove the slot cover.

4. Hold the card by the edges and firmly press the card into the PCI connector.

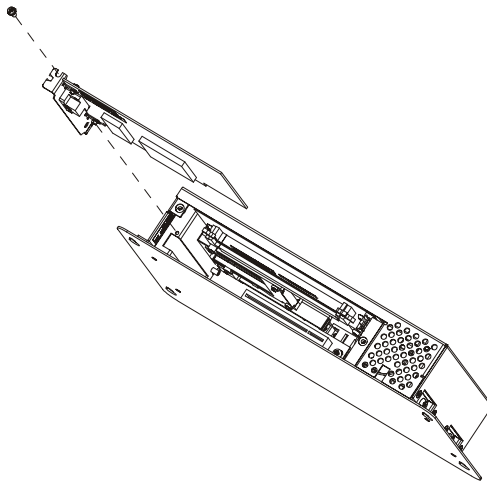

5. Align the notch in the board retainer with the threaded hole on the chassis and install the screw. Hold the notch tightly against the screw before tightening. Tighten the screw to a torque of 6 - 8 in-lbs (0.7 - 0.9 N•m).
6. Check any connectors on the PCI card to make sure they are centered in the chassis opening.
7. Reinstall the screws to secure the top cover to the chassis. Tighten the screws to 6 - 8 in-lbs (0.7 - 0.9 N•m).
8. Follow the PCI card user manual instructions when attaching any required external cables to the card.



**ATTENTION:** Some 1784 communication cards have a connector like the one used for the RAC6182 power connector. **Do not plug power into connectors on these cards.**

#### To remove a PCI card:

1. Disconnect power from the RAC6182 computer.
2. Remove the 2 screws securing the top cover to the chassis.
3. Remove any external cables attached to the PCI card.
4. Remove the screw securing the board retainer.

5. Hold the board at each end and carefully rock the board back and forth until the edge connectors pull free.
6. Store the board in an anti-static wrapper.
7. Install and secure a slot cover over the open slot. Tighten the screw to a torque of 6 - 8 in-lbs (0.7 - 0.9 N•m).
8. Reinstall the screws to secure the top cover to the chassis. Tighten the screws to a torque of 6 - 8 in-lbs (0.7 - 0.9 N•m).

## Adding/Removing RAM Memory

The RAC6182 processor board contains one standard DIMM socket. The DIMM memory can be upgraded or replaced.

The following DIMM modules can be ordered from Rockwell Automation:

Part Number	Description
6189-DIMM64	64MB SDRAM DIMM
6189-DIMM128	128MB SDRAM DIMM
6189-1DIMM256	256MB SDRAM DIMM



**ATTENTION:** DIMM memory modules are sensitive to ESD and require careful handling. Hold memory modules only by the edges--do not touch connectors. After removing a module, place it into an anti-static wrapper. Do not slide the module over any surface.

### To access the DIMM socket:

1. Turn off power to the RAC6182.
2. Remove the 2 screws securing the top cover to the chassis.
3. Locate the DIMM socket on the processor board.

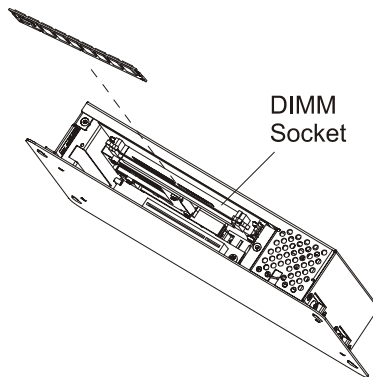

4. To remove the memory module, release the socket latches and carefully pull the module out of the socket.

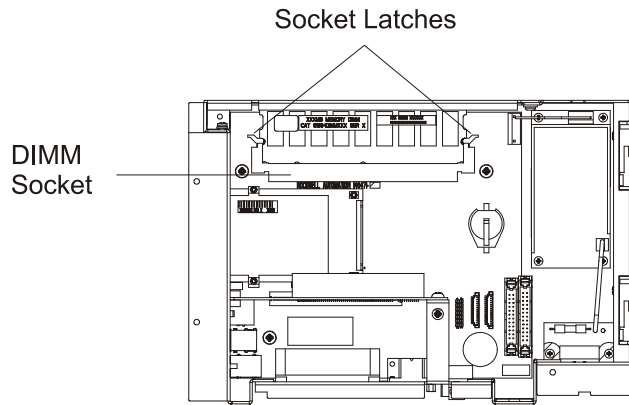

5. Store the memory module in an anti-static wrapper.
6. To install the memory module, carefully push the module into the socket. Make sure the socket latches are engaged.
7. Reinstall the screws to secure the top cover to the chassis. Tighten the screws to a torque of 6 - 8 in-lbs (0.7 - 0.9 N•m).

### Adding/Removing DiskOnChip Memory

The RAC6182 processor board contains a socketed DiskOnChip (DOC) flash memory device, which stores the Windows CE operating system and any loaded software applications and data. This DOC flash memory can be upgraded or replaced. A special Allen-Bradley DOC extraction tool is required to remove the original DOC device, and is included with the DOC removal/installation kit.



**ATTENTION:** Replacing the DOC will require you to re-install the operating system and re-load all software applications and data. For instructions on how to perform these operations, refer to Chapter 15, Managing User Applications, on page 15-1

The following DiskOnChip flash memory devices can be ordered from Rockwell Automation:

Part Number	Description
6189-2FL64	64MB flash DOC and chip extractor tool



**ATTENTION:** The DOC memory is sensitive to ESD and requires careful handling. Hold the DOC by the package – do not touch the pins. After removing the DOC, place the device in an anti-static wrapper.

**To access the DiskOnChip socket:**

1. Disconnect power to the RAC6182.
2. Follow the procedures beginning on Page 4-2 to open the chassis.
3. Locate the DOC socket on the processor board, as shown on the diagram below.

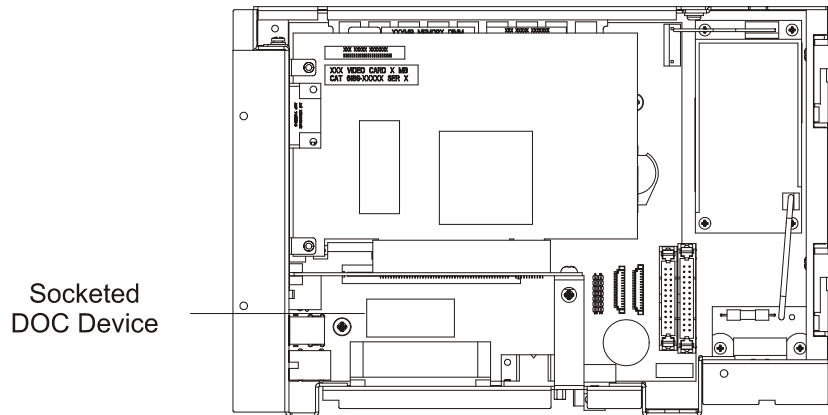

4. Use the special DOC extraction tool to hook the edges of the DOC. Be careful to hook only the DOC with the extraction tool, and not the socket located directly below the DOC.

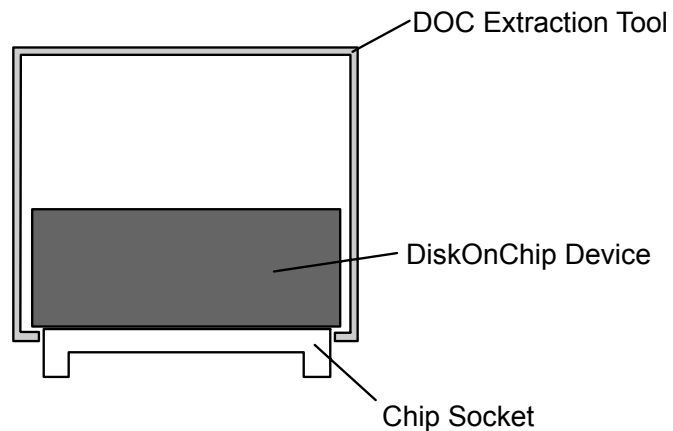



- Remove the DOC from its socket. Pull the device straight up. Be careful not to bend or damage the DOC pins.



**ATTENTION:** Make sure to hook **only** the DOC with the extraction tool, and not the socket located directly below the DOC. **Do not pull the socket** from the printed circuit board assembly. **Irreparable damage will result.**

- Store the DOC memory in an anti-static wrapper.
- Before installing the new replacement DOC memory chip, be sure it is properly oriented with regard to the chip socket. On one end of the DOC chip is a beveled corner, an inked notch, and a dot (see below).

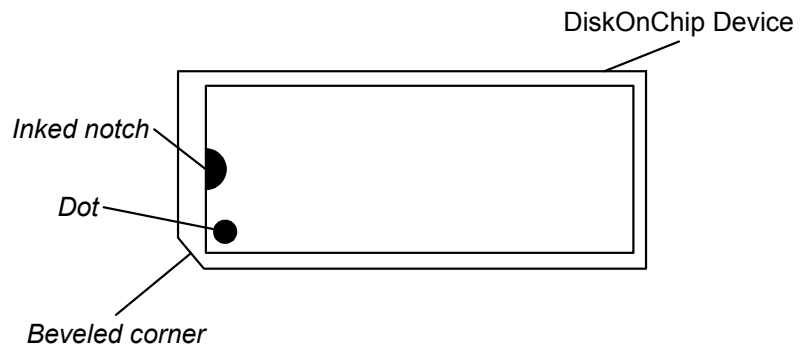

The chip socket itself contains a notch on one end (see below).

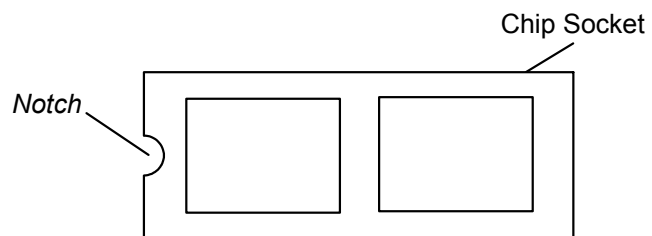

Align the end of the DOC chip containing the inked notch, dot and beveled corner with the end of the chip socket containing the notch.

- To install the DOC memory chip, carefully align all the pins with the chip socket. Gently push the pins into the socket until the chip is seated against the socket base. Make sure not to bend any pins.
- Follow the procedures on Page 4-3 to close the chassis.



## Installing/Removing Front Bezel Assembly Items

### Chapter Objectives

This chapter describes how to replace items in the RAC6182 front bezel assembly. The RAC6182 front bezel assembly consists of a plastic bezel with overlay (keypad and/or touchscreen), and a metal frame assembly that holds the LCD panel and associated interconnection circuit boards. The LCD panel has field-replaceable backlight tubes (12.1-in. versions only). The keypad bezel versions have removable function key legend strips. This chapter's topics include:

- Replacing bezel cables
- Disassembling the front bezel
- Replacing the front bezel plastic overlay
- Replacing the backlight tubes
- Installing keypad legend strips

### Safety Precautions

The RAC6182 Industrial Computer contains line voltages. Make sure you disconnect all power to the RAC6182 Industrial Computer before performing any of the operations described in this chapter.



**ATTENTION:** Disconnect all power from the RAC6182 Industrial Computer before removing components. Failure to disconnect power could result in severe electrical shock or damage to the RAC6182 Industrial Computer.

---

## Disassembling the Front Bezel

At times when repairing or replacing items on the front bezel assembly, you may need to disassemble the front bezel. You must disassemble the front bezel when you:

- Replace the front bezel plastic overlay
- Replace the vertical legend strips

### To prepare the front bezel for disassembly (all models):

1. Remove the RAC6182 from the panel or enclosure.
2. Follow the procedures on Page 4-2 to remove the computer chassis.
3. Place the front bezel assembly on a flat surface, with the overlay side down. Take care not to scratch or damage the overlay or display window.

### To disassemble the front bezel (7.7 in. display):

1. Disconnect the keypad and touchscreen cables.

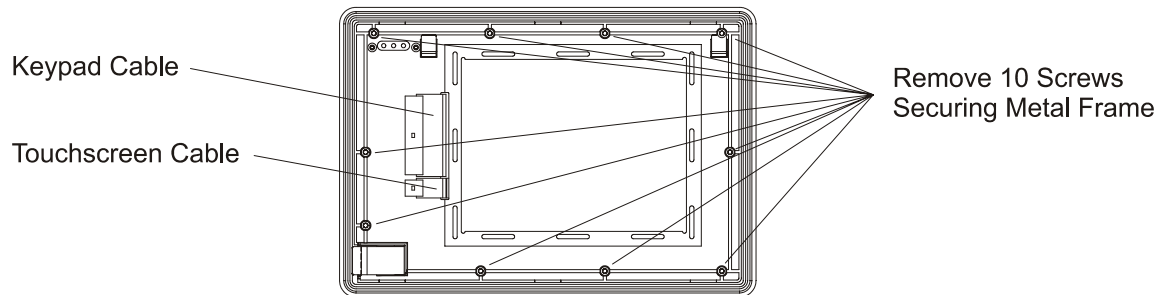

7.7 in. Display with Keypad

2. Remove the 10 screws securing the metal frame and lift the metal frame away from the plastic bezel.
3. To reassemble the front bezel assembly, thread the keypad and touchscreen cables through the hole in the metal frame.
4. Reinstall the 10 screws to attach the metal frame to the plastic overlay assembly. Tighten the screws to a torque of 6 - 8 in-lbs (0.7 - 0.9 N•m).
5. Connect the keypad and touchscreen cables.
6. Follow the procedures on Page 4-2 to reassemble the front bezel assembly to the computer chassis.

**To disassemble the front bezel (12.1 in. display with keypad):**

1. Disconnect the keypad cable, touchscreen cable, backlight tube connectors, and the backlight power supply cable as indicated in the following figure:

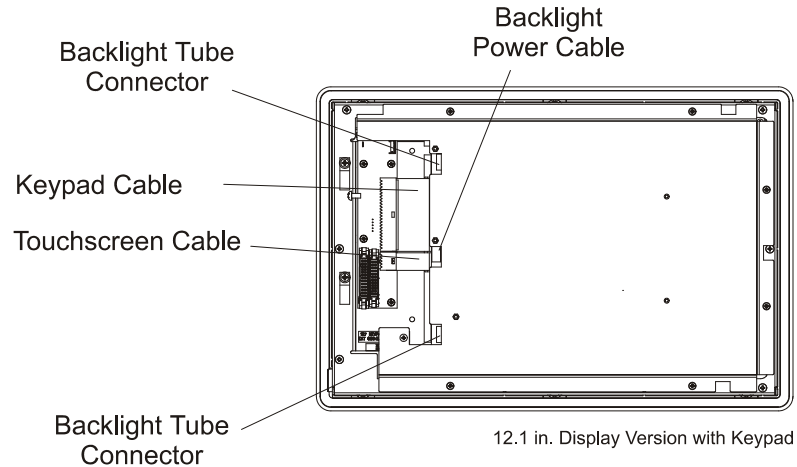

2. Remove the 6 screws securing the metal cover to the frame.

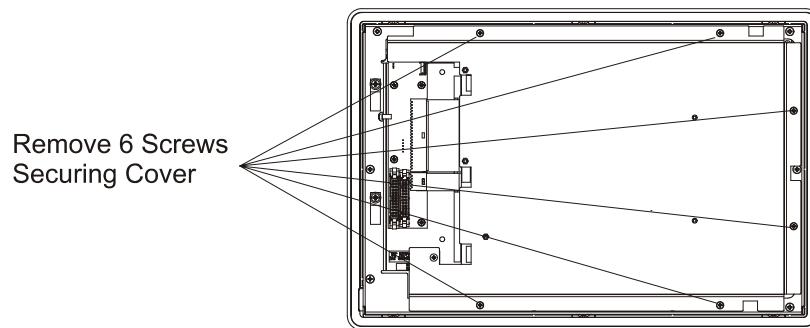

3. *If you are replacing the plastic bezel overlay or vertical legend strips, remove the 10 screws securing the metal frame and lift the metal frame away from the plastic bezel.*
4. To reassemble the front bezel assembly, thread the keypad and touchscreen cables through the hole in the metal frame.
5. Reconnect the keypad cable, touchscreen cable, backlight tube connectors, and backlight power supply cable.
6. *If you are replacing the plastic bezel overlay or vertical legend strips, reinstall the 10 screws to attach the metal frame to the plastic overlay assembly. Tighten the screws to a torque of 6 - 8 in-lbs (0.7 - 0.9 N•m).*

7. Reinstall the 6 screws to attach the metal cover to the frame. Tighten the screws to a torque of 6 - 8 in-lbs (0.7 - 0.9 N•m).
8. Follow the procedures on Page 4-2 to reassemble the front bezel assembly to the computer chassis.

**To disassemble the front bezel (12.1 in. display with touchscreen):**

1. Disconnect the backlight tube connectors as indicated in the following figure:

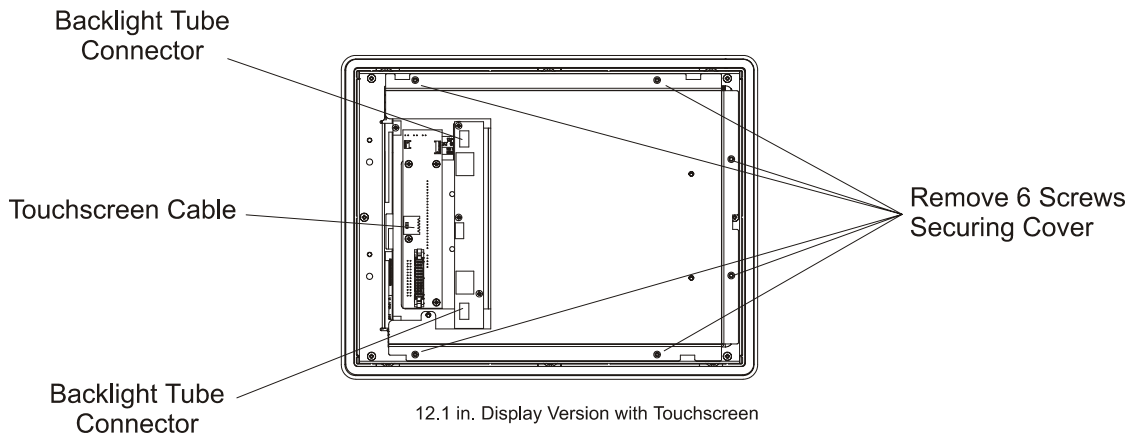

2. Remove the 6 screws securing the metal cover to the frame.

**Note:** The touchscreen controller board for the 12.1-in. touchscreen-only version is attached to the metal cover. Do not damage the touchscreen cable when loosening the cover.

3. Disconnect the touchscreen cable and remove the cover.
4. *If you are replacing the plastic bezel overlay or vertical legend strips*, remove the 10 screws securing the metal frame and lift the metal frame away from the plastic bezel.
5. To reassemble the front bezel assembly, thread the touchscreen cable through the hole in the metal frame.
6. *If you are replacing the plastic bezel overlay or vertical legend strips*, reinstall the 10 screws to attach the metal frame to the plastic overlay assembly. Tighten the screws to a torque of 6 - 8 in-lbs (0.7 - 0.9 N•m).
7. Replace the metal cover and reconnect the touchscreen cable.

8. Reconnect the backlight tube connectors and backlight power supply cable.
9. Reinstall the 6 screws to attach the metal cover to the metal frame. Tighten the screws to a torque of 6 - 8 in-lbs (0.7 - 0.9 N•m).
10. Follow the procedures on Page 4-2 to reassemble the front bezel assembly to the computer chassis.

## Replacing the Front Bezel Plastic Overlay

The plastic overlay on the RAC6182 Industrial Computer is field replaceable. You may need to replace the bezel if the bezel or a portion of a keypad is damaged. The plastic overlay assembly includes the plastic bezel, overlay, and legend strips only.

### To replace the front bezel overlay:

1. Follow the procedures in this chapter to disassemble the front bezel.
2. On the new plastic overlay assembly, remove any protective film from the inside display window. Be careful to keep this surface clean, as it cannot be cleaned once assembled.
3. *If you are replacing the bezel overlay on a 12.1-in. version with touchscreen, you must additionally remove the LED board from the existing assembly. The LED board is attached to the upper left corner of the front bezel assembly with 2 screws.*

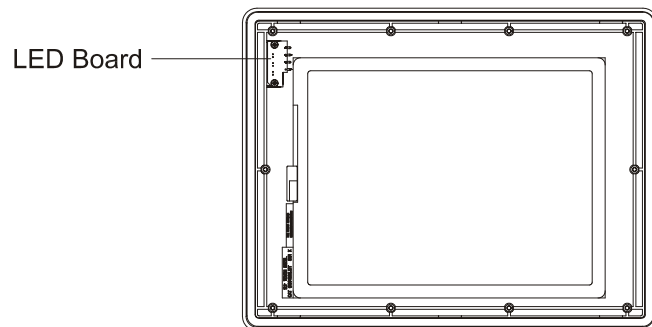

12.1 in. Display with Touchscreen

4. *If you are replacing the bezel overlay on a 12.1-in. version with touchscreen, attach the existing LED board to the new front bezel assembly using the 2 screws. Tighten the screws to 4 - 6 in-lbs (0.5 - 0.6 N•m).*
5. Place the metal frame in the new plastic overlay assembly and thread any cables through the frame as required.

6. Follow the procedures in this chapter to reassemble the front bezel, routing and connecting cables as required.
7. Remove outside display window protective film and reinstall RAC6182 computer into panel or enclosure.

The following are catalog numbers for the RAC6182 front bezel overlay assemblies. These assemblies include the plastic bezel, overlay, and legend strips only. They do not include the LCD panel or interconnection boards:

Part Number	Description
6189-2BZL8K	7.7 in. keypad bezel overlay assembly
6189-2BZL8KT	7.7 in. keypad & touchscreen bezel overlay assembly
6189-2BZL12K	12.1 in. keypad bezel overlay assembly
6189-2BZL12KT	12.1 in. keypad & touchscreen bezel overlay assembly
6189-2BZL12T	12.1 in. touchscreen bezel overlay assembly

## Installing Keypad Legend Strips

The RAC6182 keypad versions contain three legend strips – one strip for the horizontal function keys located below the display and two strips for the vertical function keys located on either side of the display. Each of these legend strips can be removed and replaced with custom printed versions. Contact Rockwell Automation for more information on how to obtain customized legend strips.

The standard legend strips shipped with the product are configured as follows:

Legend Strip	Description
7.7 in. horizontal strip	F1-F11 printed on exposed side, user-writable surface on the reverse side.
7.7 in. left vertical strip	K1-K8 printed on exposed side, user-writable surface on the reverse side.
7.7 in. right vertical strip	K9-K16 printed on exposed side, user-writable surface on the reverse side.
12.1 in. horizontal strip	F1-F14 printed on exposed side, user-writable surface on the reverse side.
12.1 in. left vertical strip	K1-K10 printed on exposed side, user-writable surface on the reverse side.
12.1 in. right vertical strip	K11-K20 printed on exposed side, user-writable surface on the reverse side.

The following replacement legend strips can be ordered from Rockwell Automation. Each kit contains one each of the three legend strips – horizontal, left vertical, and right vertical strips. They are configured as listed above with text printed on one side and a user-writable surface on the other side.



Part Number	Description
6189-2KEYKIT8	7.7 in. bezel legend strip kit (3 pcs)
6189-2KEYKIT12	12.1 in. bezel legend strip kit (3 pcs)

**To replace the horizontal legend strip (7.7 in. & 12.1 in. versions):**

1. Locate the exposed legend strip tab on the lower left side of the RAC6182 unit.

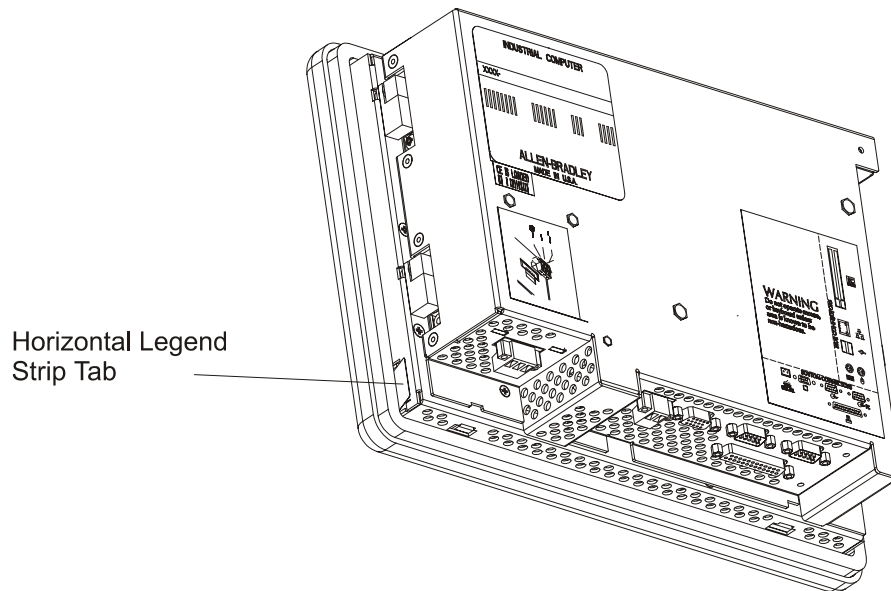

2. Carefully pull on the tab to remove the installed legend strip.
3. To insert the new legend strip, first slightly cup the strip and carefully push it into the bezel slot. Short pushes will help slide the new strip fully into place.
4. Verify the alignment of the legend strip text on the front overlay keys. Adjust as needed by pushing or pulling slightly on the legend strip tab.

**To replace the vertical legend strips (7.7 in. & 12.1 in. versions):**

1. Follow the procedures in this chapter to disassemble the front bezel.
2. Place the front bezel plastic overlay facedown on a flat surface. Take care not to scratch the front overlay or display window. Locate the two exposed legend strip tabs as shown.

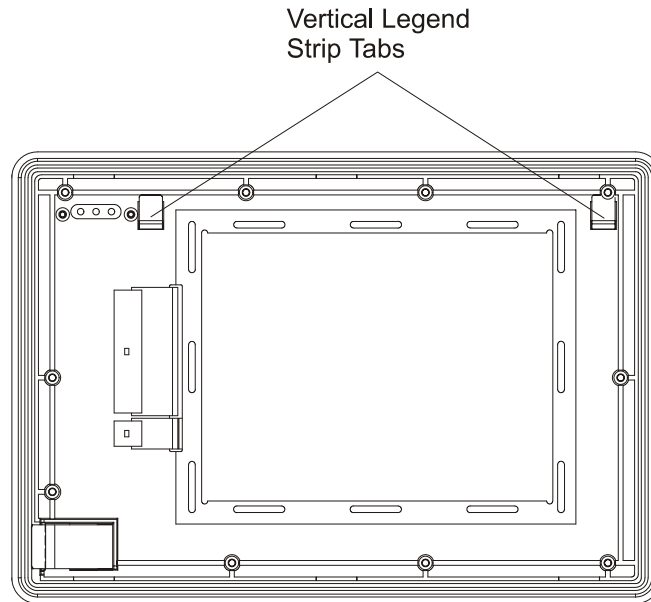

3. To remove the legend strips, carefully pull on the exposed tab.
4. To insert new legend strip, first slightly cup the strip and carefully push it into the bezel slot. Short pushes will help slide the new strip fully into place.
5. Verify the alignment of the legend strip text on the front overlay keys. Adjust as needed by pushing or pulling slightly on the legend strip tab.
6. Follow the procedures in this chapter to reassemble the front bezel, routing and connecting cables as required.

## Initial Operation and Setup

### Chapter Objectives

This chapter provides information on:

- operating recommendations
- boot-up sequence
- system reset

### Operating Recommendations

Rockwell Automation recommends that you not operate the RAC6182 Industrial Computer with covers removed. An electrical shock hazard exists. In addition, removing the covers disrupts air flow and may result in overheating. All covers are required to maintain EMI compliance.

### Operator Access

Operator access is limited to the front panel of the RAC6182 Industrial Computer. This includes the display, keypad, and touchscreen. Access to components behind the rack or panel in which the RAC6182 Industrial Computer is installed is restricted to authorized and properly trained personnel.

### System Checkout

To boot up the system:

1. Install the RAC6182 Industrial Computer using the procedures in the following chapters:

Chapter 2, Installation

Chapter 3, Connecting External Devices

Chapter 4, Adding/Removing Internal Components.

2. Apply power. The RAC6182 Industrial Computer performs a Power On Self Test (POST) in which it tests the internal hardware and software integrity. The display is not immediately activated during the POST. If any failures occur, the Fault LED is turned on and the boot process is terminated.
3. Upon successful completion of the POST, the RAC6182 Industrial Computer loads the Microsoft Windows CE operating system from flash ROM into RAM. The Desktop is displayed and any applications configured for auto-start are started.

**Note:** The entire power-up process takes approximately 20 seconds. The display is not active for a large portion of the boot time, but the front panel LEDs toggle to indicate that the RAC6182 Industrial Computer is powering up.

4. Use the procedures in Chapter 15, Managing User Applications, to load and manage additional software applications and data files.
5. If your system does not boot up, or if you notice other problems, refer to Chapter 16, System Troubleshooting.

## System Reset

To reset the RAC6182 Industrial Computer, cycle external power to the unit.

After resetting, the RAC6182 Industrial Computer begins the Power On Self Test (POST). During reset, the RAC6182 Industrial Computer:

- Clears RAM
- Starts the POST
- Loads the operating system
- Starts designated applications.

## Windows CE Operating System

### Chapter Objectives

This chapter provides information on:

- Windows CE architecture
- Windows CE programs
- Using Windows CE
- Control Panel applications
- RAC6182 Computer memory usage

### Windows CE Architecture

The Windows CE operating system from Microsoft is designed to provide a portable, scalable, real-time operating system for embedded devices. The modular design of Windows CE allows the application designer to include only those features required for the specific product application. However, Windows CE is still a subset of the other Microsoft operating systems, and it runs Win32 applications.

### Windows CE Benefits

There are two major differences between Windows CE and other Microsoft Windows operating systems. Windows CE:

- Has a small memory footprint requirement
- Runs on a wide variety of processor architectures.

The small memory footprint allows Windows CE to operate in small solid-state memory devices (8 MB typical). In contrast, PC-based Windows require hundreds of megabytes of storage space.

PC-based Windows applications operate only on Intel x86 compatible architectures. Embedded devices using Windows CE can use low-cost and low-power processors with optimal features and functionality for the specific application.

### Compiling Windows CE Applications

While the Windows CE operating system brings a higher level of standardization to embedded computing devices, third-party software applications must still be compiled and tested to run on each Windows CE device. The compilation is required to tailor the software application to the device's processor and unique hardware features.

Microsoft created hardware reference models for the Handheld (HPC) and the Pocket (PPC) PC so that third-party applications can run on these standard platforms. There are no hardware standards for embedded devices.

The RAC6182 Industrial Computer is largely compatible with HPC and PPC, so applications that are compiled for the MIPS or MIPSFP may run on the RAC6182.

## RAC6182 Standard Windows CE Programs

The Windows CE programs that come with the RAC6182 Computer are stored in flash memory and cannot be inadvertently lost. Additional programs can be installed as described in Chapter 15, Managing User Applications.

The RAC6182 Computer ships with the following programs preloaded:

**Table K**  
**RAC6182 Standard Applications**

Application	Purpose
Microsoft Internet Explorer	Web browser.
PC Link and ActiveSync	Connects the RAC6182 to a desktop computer running ActiveSync.
Control Panel	A set of configuration tools for setting up the RAC6182.
Microsoft Explorer (Shell)	A user interface to the system much like a desktop PC.

Terminal Services for thin client applications is included in the RAC6182 Accessories CD. Refer to the Terminal Server Client wizard for installation procedures.

There are other Windows CE programs available. Most of these programs have been written for HPC devices, and some may run on the RAC6182 Industrial Computer. Visit Microsoft Windows CE web site at <http://www.microsoft.com/windowsce/> for more information on Windows CE programs.

The RAC6182 Industrial Computer is available with Rockwell Software RSView Machine Edition CE operator interface program. Refer to the associated software program's user manual shipped with the RAC6182 Industrial Computer for information about using that program.

## Installing Applications

The RAC6182 Industrial Computer is designed for field-installation of third-party software programs. Chapter 15, Managing User Applications,

discusses how to use Microsoft ActiveSync to install and remove application programs on the RAC6182 Industrial Computer. Each application program must be compiled for the MIPS RISC processor.

If the application program literature does not specifically identify the RAC6182 Industrial Computer as a compatible hardware platform, take caution if trying to install and run it on the RAC6182 platform. While the program may operate on the MIPS processor, there could be conflicts on the RAC6182 Industrial Computer. Testing is essential.

## Using Windows CE

The Windows CE operating system provides a user interface very similar to other Microsoft Windows operating systems. This user interface has been simplified somewhat to reduce the memory footprint, so there are some minor differences between a desktop Windows interface and the Windows CE interface.

The RAC6182 Industrial Computer has a keypad and/or touchscreen for operator input. In addition, an external keyboard and mouse can be connected. The Windows CE graphical interface simplifies interaction with the computer. You simply select and move objects on the screen by tapping and dragging them using your finger or stylus on the touchscreen, or using an external mouse.

**Note:** If you have difficulty selecting objects using the touchscreen, run the calibration program described in Chapter 11, Touchscreen Calibration.

## Start Menu and Taskbar

The Start menu is used to run programs, configure settings, and open recently-used documents. A single-click on the Start menu button on the bottom left of the screen brings up the menu. Subsequent clicks select the program or item you want to open. The key sequence Ctrl+Esc also activates the Start menu.

The taskbar across the bottom of the screen contains buttons for programs already running, along with a status area and a Desktop icon. You can alternately minimize and maximize an open application by clicking on its taskbar button. Double-clicking on any icon in the status area shows more information about that function. A single-click on the Show Desktop button (far right side of taskbar) minimizes all open windows and displays the RAC6182 Industrial Computer Desktop. You can close an application by clicking with the right mouse button on its taskbar button and choosing Close.

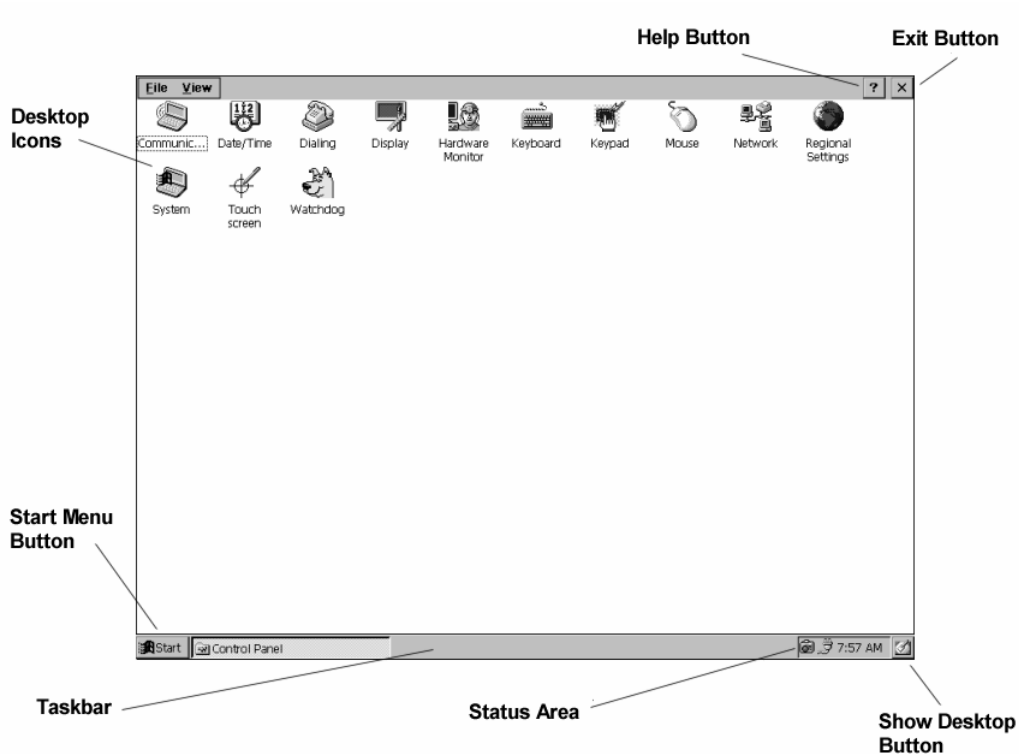

## Command Bar

Each program window has a command bar located across its top. This command bar contains pull-down menu names and toolbar buttons for the application.

Click on a menu name or toolbar icon to interact with the specific program. The Help (?) button on the right side of the command bar provides application-specific help. The Exit (X) button on the far right side of the command bar exits the application.



There is no Minimize button on the Windows CE command bar. Click the taskbar button to minimize a program window, or use the Show Desktop button to minimize all open program windows.

## Finding Files

Select Start-Programs-Windows Explorer to locate files on the RAC6182 Industrial Computer. You can alternately double-click the My Computer icon on the Desktop to open the Windows Explorer program. Windows Explorer allows you to browse and manipulate the RAC6182 files and folders. The Edit menu allows you to move files from one location to another using the Copy or Cut and Paste commands. When you create and save a new file, it is stored in the My Documents folder unless you specify another location.

**Note:** The RAC6182 Computer does not provide persistent storage of the My Documents folder. All documents to be saved should be stored under the *\Storage Card* folder.

## Browsing Web Pages

Select Start-Programs-Internet Explorer to view Web pages. You can alternately double-click the Internet Explorer icon on the Desktop to open the Internet Explorer program. To access pages stored on the RAC6182 Industrial Computer, use the File-Open command and select the Browse button to locate the file. To view Internet or Intranet pages, type a URL in the Address box.

Before you can access remote Web pages, the RAC6182 Industrial Computer must be connected to a network. See Chapter 14, Communications Configuration, for configuring the Ethernet interface. Additional network settings such as a Proxy Server can be configured in the Internet Explorer application using the Options command under the View menu.

The Microsoft Internet Explorer application is a functional subset of the PC version. It offers many of the same features of the PC version, and can be used to view most Internet HTML web pages. Some advanced web features may not be fully supported.

## Printing

Some RAC6182 software applications may support printing. To print from these applications, select the Print command from the File menu. An HP-compatible printer must be connected to the RAC6182 parallel port.

## Control Panel Applications

### Configuring the RAC6182 Industrial Computer

There are several user-configurable settings on the RAC6182 Industrial Computer. These settings are accessed from the Windows CE Control Panel. Select Start-Settings-Control Panel to open the Control Panel window.

The Windows CE operating system contains a number of native functions and interfaces. Many of these features are very similar to other Microsoft Windows operating systems. The Windows CE Control Panel contains the following common or native applications. Click on the associated Control Panel icon and use the Help (?) button to learn more about each application's usage.

**Table L**  
**Control Panel Applications on the RAC6182**

Application	Purpose
Communications	Configuring the RAC6182 PC connections. For more information, refer to Chapter 14.
Date/Time	Setting the date and time on the RAC6182.
Dialing	Proving a dial-up connection. Use with a Windows CE compatible PC card modem.
Display	Configuring display and color settings, external video port, and setting LCD backlight and contrast settings. For more information, refer to Chapter 10.
Keyboard	Setting up a keyboard device.
Keypad	Configuring RAC6182 keypad functionality. For more information, refer to Chapter 9.
Mouse	Setting up a mouse device.
Network	Setting up Ethernet network connectivity. For more information, refer to Chapter 14.
Regional settings	Setting clock and calendar, along with default number and currency formats.
Touchscreen	Calibrating the touchscreen and setting other touchscreen options. For more information, refer to Chapter 11.
System	Listing system properties like memory allocation, device information, operating system version, bundled applications, and device registration.
Hardware Monitor	Viewing the RAC6182 voltage and temperature, resetting the fault LED, and viewing the event log.
Watchdog Timer	Starting or stopping the software watchdog timer.

## RAC6182 Memory Usage

The RAC6182 Industrial Computer has five internal memory areas. These are:

- Boot flash ROM
- DiskOnChip flash ROM (32MB typical)
- Dynamic RAM (32MB typical)
- Battery-backed non-volatile RAM (128KB)
- Flash memory PC cards

### Boot Flash ROM

The RAC6182 Industrial Computer's boot flash ROM is used to power-up the RAC6182 Industrial Computer, perform the power-up self tests, and load the Windows CE operating system from the DOC flash ROM into the dynamic RAM. The boot flash ROM code is not user accessible.

### DiskOnChip Flash ROM

The RAC6182 DiskOnChip (DOC) flash ROM is the main storage memory on the RAC6182 Industrial Computer. The Windows CE operating system is stored in a protected segment of the DOC flash ROM. User applications are also stored on the DOC. Upon power-up, the operating system and any auto-start applications are transferred from the DOC to dynamic RAM, where they are executed.

The remainder of the DOC flash ROM is a FAT partition that appears as a folder named *\Storage Card* in Windows CE. Files stored here are persistent.

**Note:** Only programs and files loaded in the *\Storage Card* folder are saved in the DOC flash ROM. All other folders or files existing in DRAM and are lost when power is cycled.

### Dynamic RAM

The RAC6182 dynamic RAM memory is split into two segments: storage memory and program memory. The Control Panel System application has a slider control that determines the allocation mix between Storage and Program memory.

The storage memory segment is a virtual RAM disk known as the Object Store. It provides specialized storage for the Windows CE Registry, the Windows CE file system, and Windows CE system databases. The

RAM-based storage memory segment is *not* persistent as in HPC devices, so all files stored here must be re-created at every startup.

The program memory segment provides traditional computer RAM-like functions for holding application code, heaps, stacks, and data at run-time. The RAC6182 Industrial Computer loads the Windows CE operating system and any auto-start applications from the DOC flash ROM into the program memory at power-up.

### **Battery-Backed Non-Volatile RAM**

The battery-backed RAM memory is a small segment of persistent RAM memory that is available for any application to use. An application accesses the non-volatile RAM using a specialized API.

### **Flash Memory PC Cards**

The RAC6182 memory can be expanded using a non-volatile flash memory PC card. When a flash memory card is installed, a new StorageCard2 or StorageCard3 icon is displayed under My Computer, and files in the memory card can be manipulated using the Windows Explorer program.

Two PCMCIA Type2 cards or one PCMCIA Type 3 card may be used. These must be ATA compatible. For information on compatible cards and for instructions on installing them, refer to Chapter 4, Adding/Removing Internal Components.

## Keypad Operation

### Chapter Objectives

This chapter describes how to configure and operate the front bezel keypad on associated RAC6182 versions. This chapter's topics include:

- Keypad operation
- Keypad layout
- Configuring the Keypad application

### Keypad Operation

The 7.7 in. and 12.1 in. display versions of the RAC6182 Industrial Computer are available with a front bezel keypad. This keypad provides an operator interface to the RAC6182 Industrial Computer. The RAC6182 keypad operates like an external PC keyboard, sending key press and key release information to the Windows CE operating system. Additional custom functionality is incorporated in the keypad design for industrial control applications.

**Note:** The RAC6182 Industrial Computer supports up to 3 keyboard interfaces simultaneously – the bezel keypad, an external PS/2 keyboard, and an external USB keyboard. Caution must be exercised when designing multiple-interface systems, as simultaneous operation of multiple keyboards may cause unexpected actions.

### Keypad Layout

The RAC6182 keypad consists of a numeric keypad, control keys, navigation keys, and user-programmable function keys. The 7.7 in. keypad and 12.1 in. keypad are the same, except the 12.1 in. version contains 7 more function keys.

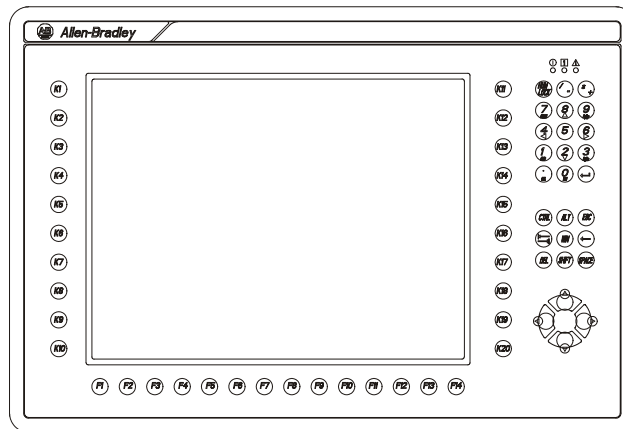

**Note:** 12.1 in. display version shown.

## Numeric Keypad

The numeric keypad contains the following keys. The numeric keypad keys are blue. The NUMLOCK key changes the key definitions as shown below. The NUMLOCK status LED is lit when the NUMLOCK function is activated.

**Table M**  
**Numeric Keypad Functions**

Key	NUMLOCK On	NUMLOCK Off
0	0	INS (insert)
1	1	END (end)
2	2	(down-arrow)
3	3	PG DN (page down)
4	4	(left-arrow)
5	5	(none)
6	6	(right-arrow)
7	7	HOME (home)
8	8	(up-arrow)
9	9	PG UP (page up)
.	.	DEL (delete)

## Control & Navigation Keys

The control and navigation keys are black. They have the following key definitions.

**Table N**  
**Control and Navigation Keypad Functions**

Key	Unshifted	Shifted	Description
/ -	-	/	Backslash or minus sign
* +	+	*	Asterisk or plus sign
			Enter key
CTRL			Control key
ALT			Alternate key
ESC			Escape key
	(tab)	(back tab)	Tab key
WIN			Windows key
			Backspace key
DEL			Delete key
SHIFT			Shift key
SPACE			Space key
△			Left-arrow key
◀			Up-arrow key
△			Right-arrow key
▷			Down-arrow key

## Function Keys

The function keys are located below and on either side of the display window.

The 7.7 in. version has 11 function keys below the display (F1-F11), and a row of 8 function keys on each side of the display (K1-K8, K9-K16), for a total of 27 function keys.

The 12.1 in. version has 14 function keys below the display (F1-F14), and a row of 10 function keys on each side of the display (K1-K10, K11-K20), for a total of 34 function keys.

The default key configurations are listed below. The key identifier represents the factory-shipped legend strip characters.

**Table O**  
**Function Key (F-Key) Keypad Functions**

7.7 in. Key	Default	12.1 in. Key	Default
F1	F1	F1	F1
F2	F2	F2	F2
F3	F3	F3	F3
F4	F4	F4	F4
F5	F5	F5	F5
F6	F6	F6	F6
F7	F7	F7	F7
F8	F8	F8	F8
F9	F9	F9	F9
F10	F10	F10	F10
F11	F11	F11	F11
		F12	F12
		F13	left Shift + F1
		F14	left Shift + F2



**Table P**  
**Function Key (K-Key) Keypad Functions**

7.7 in. Key	Default	12.1 in. Key	Default
K1	right Alt + F1	K1	right Alt + F1
K2	right Alt + F2	K2	right Alt + F2
K3	right Alt + F3	K3	right Alt + F3
K4	right Alt + F4	K4	right Alt + F4
K5	right Alt + F5	K5	right Alt + F5
K6	right Alt + F6	K6	right Alt + F6
K7	right Alt + F7	K7	right Alt + F7
K8	right Alt + F8	K8	right Alt + F8
K9	right Alt + F9	K9	right Alt + F9
K10	right Alt + F10	K10	right Alt + F10
K11	right Alt + F11	K11	right Alt + F11
K12	right Alt + F12	K12	right Alt + F12
K13	right Shift + F1	K13	right Shift + F1
K14	right Shift + F2	K14	right Shift + F2
K15	right Shift + F3	K15	right Shift + F3
K16	right Shift + F4	K16	right Shift + F4
		K17	right Shift + F5
		K18	right Shift + F6
		K19	right Shift + F7
		K20	right Shift + F8

## Specialized Keypad Functionality

The RAC6182 keypad has unique user-configurable functionality to enhance its use in industrial control applications. Configuring the RAC6182 keypad functionality is done using the Keypad application in the Windows CE Control Panel and the Keypad Configuration Utility.

**Note:** A Keypad Configuration Utility (KCU) for the RAC6182 Industrial Computer can be installed on a desktop PC from the RAC6182 Applications and Accessories CD. See “Setting Up and Using the Keypad Configuration Utility Software” in this chapter on page 8-8 for more information.

### Repeat Mode

Repeat mode is selected using the Repeat tab on the Control Panel Keypad application. When enabled, a key that is held down sends out repeated "key-down" events until the key is released, and a last "key-up" event is sent. The repeat rate, delay interval and the delay between the first key press and the repeating actions are user configurable.

Function keys set for single-character mode exhibit typematic behavior. Function keys set for macro-string mode do not exhibit typematic or repeating behavior. *The factory default for all keys is repeat mode.* The

Keypad Configuration Utility is required to program the function keys for different modes and characters.

### **Multi-Key Lockout Mode**

Multi-key lockout mode disables any subsequent key presses while an existing function key is still depressed. When enabled and a function key is pressed, all other key presses are ignored until the function key is released. Likewise, if the Alt, Ctrl, or Shift keys are pressed, all function keys are inhibited until the modifier key is released.

An abort option allows the immediate discontinuation of all key operations if a function key is depressed and any other key is pressed while the first key is held down. Upon abort, the first key's "key up" event is sent. No other key actions are recognized until all keys are released. Use the Control Panel Keypad application to select this mode. *The factory default is unselected.*

### **Hold-Off Mode**

Hold-off mode allows the user to program a hold-off delay timer from 100 milliseconds to 5 seconds. When active, multiple key presses of the same key are ignored for the duration of the delay timer. This mode acts against key teasing. If a key is held down, the typematic rules still apply. Use the Control Panel Keypad application to configure this mode. *The factory default is unselected.*

## Setting Up the Keypad

You configure the RAC6182 Industrial Computer keypad using the Keypad application in the Windows CE Control Panel.

### To change the keypad operation:

1. To start the Keypad application, select Start-Settings-Control Panel. Select or double-click on the Keypad icon.

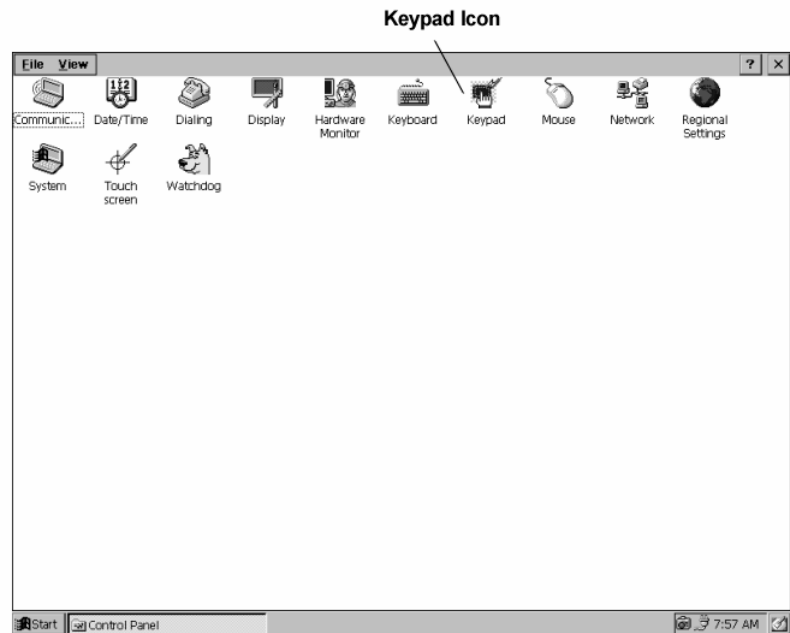

2. On the Repeat tab, select the following options as necessary:

To enable repeating for all keys, select the Enable Character Repeat checkbox.

To adjust how much time elapses before characters repeat, drag the Repeat Delay slider control.

To adjust how quickly characters repeat when you hold down a key, drag the Repeat Rate slider control.

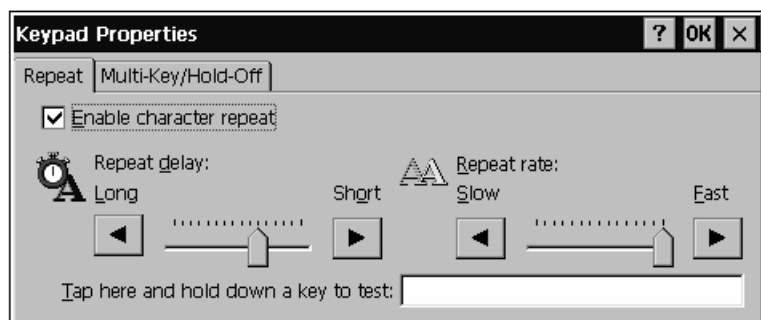

- On the Multi-Key/Hold-Off tab, select the following options as necessary:

To enable hold-off for all programmable (blue) keys, select the Hold-Off Mode checkbox.

To adjust how much time must elapse before another programmable key is recognized, drag the Hold-Off Delay slider control.

To enable multi-key lockout for all programmable (blue) keys, select the Multi-Key Lockout Enable checkbox.

To enable multi-key lockout with abort for all programmable (blue) keys, select the Multi-Key Lockout Enable with Abort checkbox.

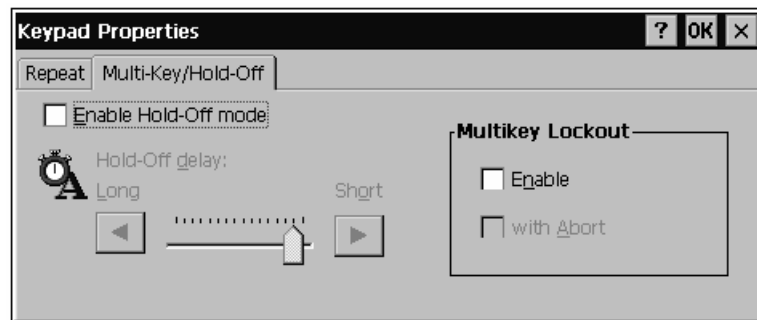

- Press Enter or click the OK button to save the settings and exit.

## Setting Up and Using the Keypad Configuration Utility Software

The RAC6182 Industrial Computer Keypad Configuration Utility (KCU) is a PC-based program that allows you to modify, view, print, save, recall and download keypad configurations to any RAC6182 Industrial Computer with a keypad. Keypad configurations are uploaded and downloaded from a PC to the RAC6182 computer using the ActiveSync program. The Keypad Configuration Utility requires an ActiveSync connection between the RAC6182 and the PC.

For each keypad configuration you can do the following to one or more keys:

- Enable or disable
- Re-establish the factory default setting
- Assign a new key mapping
- Assign a macro string
- Assign a run program command

The resultant codes for single key are often referred to as the *definition* or *mapping* of the key. The collection of all keys' definitions is commonly called the *Keypad Configuration*.

**Hint:** If you modify the Keypad Configuration, you should save the new configuration to a Keypad Configuration File (\*.KY2). This file can be downloaded into other RAC6182 computers to provide the same keypad behavior, or used to reload the desired configuration into a replacement RAC6182 computer.

The Keypad Configuration is stored in the RAC6182 registry. At run-time, a special program called the Keypad Handler (kh.dll) is a companion to the keypad driver. The keypad driver submits each key press to the Keypad Handler, which uses the registry to determine how the key press should be translated and returned to the operating system. The Keypad Handler can inhibit the key press, launch a program, or return one or more codes. The operating system then forwards the resultant code(s) to the application with current focus.

## System Requirements

The RAC6182 Keypad Configuration Utility is a Microsoft Windows application that runs on an PC with Windows 9x, Windows NT, or Windows 2000. ActiveSync 3.0 or greater with a serial or Ethernet connection to the RAC6182 is required. The KCU program requires about 3MB of disk space. There are no unique device drivers.

## Installing the Keypad Configuration Utility

The Keypad Configuration Utility software is distributed on the RAC6182 Applications and Accessories CD with every RAC6182 Industrial Computer. It can also be obtained by contacting Allen-Bradley technical support at (440) 646-5800.

### To install the RAC6182 Keypad Configuration Utility software using Control Panel:

1. Insert the CD named "RAC6182 Applications and Accessories" into your CD drive.
2. Click the Start button, click Settings, and then click the Control Panel.
3. Click the Add Programs button or icon.
4. Click the CD button and browse to the folder "Keypad Configuration Utility".

5. Select and open the file named “setup.exe”.
6. Follow the install instructions on the screen.

**To install the RAC6182 Keypad Configuration Utility software using Run:**

1. Insert the CD named RAC6182 Applications and Accessories into your CD drive.
2. Click the Start button and select Run from the menu.
3. Browse the CD to the folder “Keypad Configuration Utility”.
4. Select and open the file named “setup.exe”.
5. Follow the install instructions on the screen.

**To Uninstall the RAC6182 Keypad Configuration Utility software using Control Panel:**

1. Click the Start button, click Settings, and then click the Control Panel.
2. Click the Remove Programs button or icon.
3. Select the RAC6182 Keypad Configuration Utility from the list of currently installed programs.
4. Click the Remove button or icon.
5. Follow the install instructions on the screen.

**Configuration Files**

The RAC6182 Keypad Configuration Utility recognizes a file with the extension \*.KY2 as a RAC6182 keypad configuration. Opening a file with this extension should launch the RAC6182 Keypad Configuration Utility.

## Connecting the RAC6182 Computer to the PC Computer

When the RAC6182 Keypad configuration Utility runs, it first looks for an ActiveSync connection to a RAC6182 computer. That is why essential first steps are to ensure that ActiveSync is installed on the PC and to establish an ActiveSync connection between the PC and the RAC6182 Industrial Computer. The connection can be serial or Ethernet. If you are unfamiliar with ActiveSync and RAC6182 communications, please see Chapter 13, Communications Configuration, and Chapter 14, Managing User Applications.

**Note:** ActiveSync 3.0 is distributed on the RAC6182 Applications and Accessories CD with every RAC6182 Industrial Computer.

## Using the Keypad Configuration Utility

To run the Keypad Configuration Utility:

1. On the RAC6182, run PC Link to start the ActiveSync connection.
2. On the PC, open the Start menu. Open the Programs submenu and select the RAC6182 Keypad Configuration Utility.
3. Click on the icon to run the RAC6182 Keypad Configuration Utility.
4. The Keypad Configuration Utility opens and shows the keypad and the current configuration that is stored in the registry of the RAC6182. Depending on the type of RAC6182 Industrial Computer, the keypad will be either the 7.7 in. STN bezel with 27 function keys or the 12.1 in. TFT bezel with 34 function keys.

The window that contains the keypad configuration stored on the RAC6182 computer is named RAC6182 Keypad Configuration.

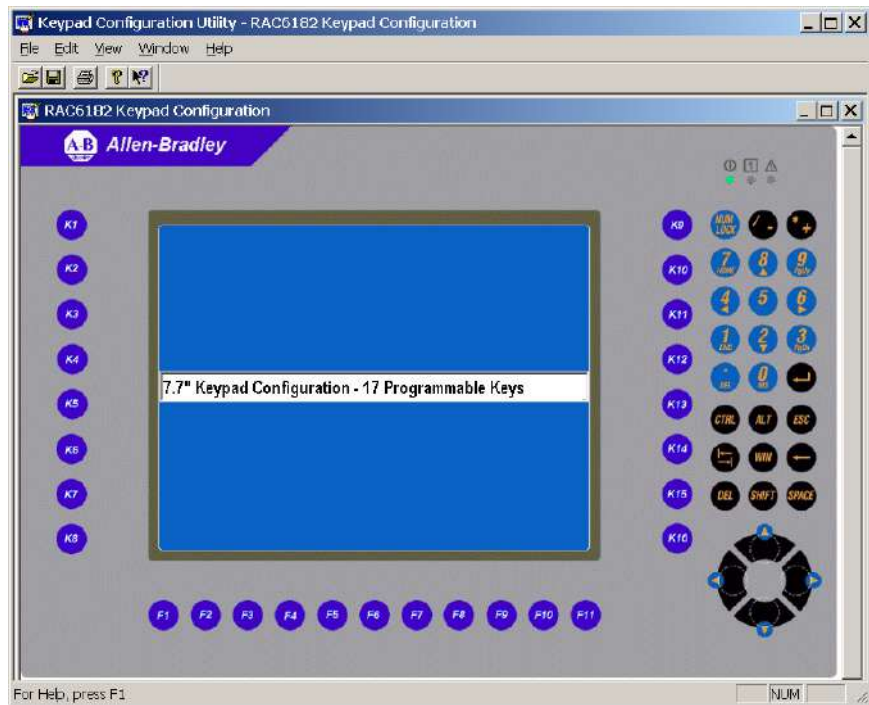

**Figure 1**  
**7.7 in. Bezel with Keypad**

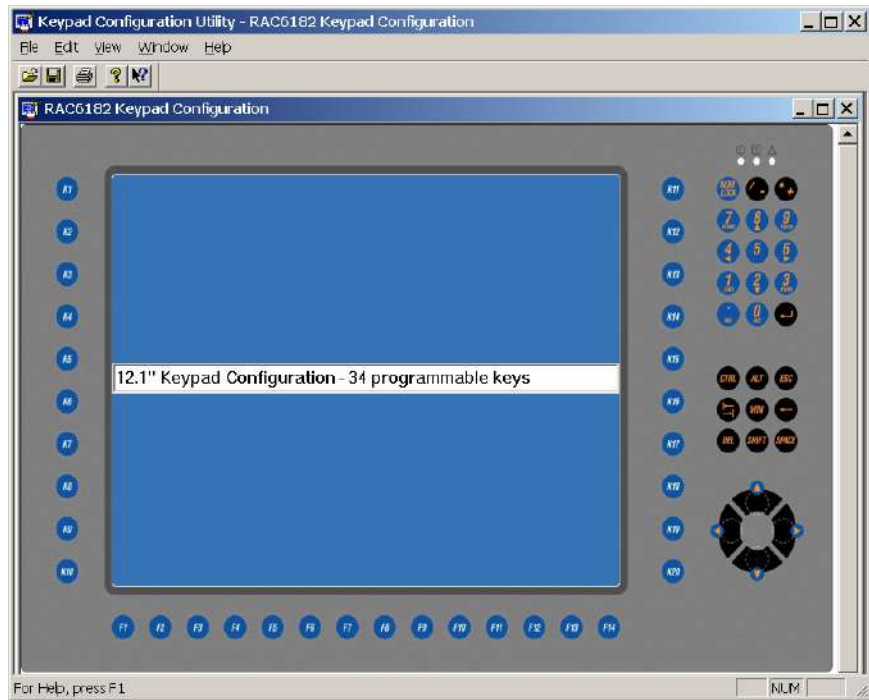

**Figure 2**  
**12.1" Bezel with Keypad**



You can now:

- Modify the keypad configuration and download it to the RAC6182.
- Modify the keypad configuration and save it as a \*.KY2 file.
- Recall and modify an existing keypad configuration (\*.KY2 file) and download it to the RAC6182.

Operations available from the menu bar are as follow:

Select commands on this menu:	To
File Menu	Open, close, and save configuration files, print preview and print keypad configuration files.
Edit Menu	Select all keys or just the programmable keys, enable/disable keys, restore default configuration, edit single key configurations, and set keypad behavior attributes.
View Menu	Toggle the tool bar or status bar on or off, or view the keypad identifiers of the current Keypad Configuration.
Window Menu	Opens a new window and arranges open windows and keypad icons.
Help Menu	Display a list of help topics or the current version number of the 6181 Keypad Configuration Utility.

## RAC6182 Keypad Configuration Window

A keypad configuration appears as a separate window. Most operations are done within this window.

You can:

- enter a description of the Keypad Configuration.
- open a saved Keypad Configuration file (\*.KY2).
- select one or more keys.
- enable/disable all or specific keys.
- set the default configuration for all the programmable keys or all the keys.
- edit the definition of the programmable keys.

change a programmable key to a new key; e.g. F1 'a'

assign a macro string to a programmable key; e.g. F2 "RAC6182"

assign a run program command to a programmable key; e.g. K1  
"\\Windows\\ipconfig.exe"

## Entering a Keypad Description

The text edit box appears near the center of the keypad configuration window and allows you to enter a description to identify the Keypad Configuration. The text edit box accepts up to 128 characters. To edit a description, simply click in the text edit box and start typing or editing the text. With the cursor in the text edit box, click the right mouse button to open the popup menu. Use the commands on this menu to copy/cut, paste and delete selected text. To select all the text in the description box, choose Select All from the popup menu. The new keypad description can be downloaded to the RAC6182 when you select Download Keypad Configuration to RAC6182... on the File menu, or can be saved to a file when you select Save or Save As... on the File menu.

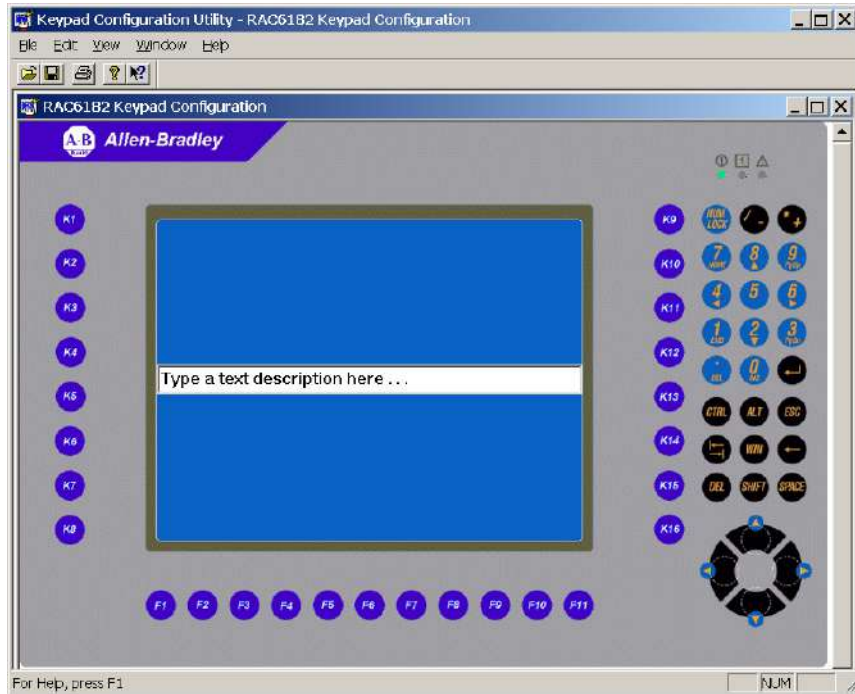

**Figure 3**  
**Text Description**

## Selecting Keys

The table below shows how to select keys on the keypad. You must select a key before you can enable or disable the key or modify its configuration.

To Select:	Do This:	The result is:
Single key	Click the left mouse button on the key.	The selected key is highlighted with handles.
Group of keys	Click the left mouse button and drag the selection rectangle around the keys you want to select.	The selected keys are highlighted with handles.
All keys	Choose Select All Keys from the Edit menu.	All keys are highlighted with handles.
All Programmable Keys	Choose Select All Programmable Keys from the Edit menu.	All programmable keys are highlighted with handles.
Multiple Keys	Click the left mouse button sequentially on the desired keys while holding down the Ctrl key.	The selected keys are highlighted with handles.

## Enabling and Disabling Keys

You can enable/disable all or specific keys on the keypad. By default, all keys are initially enabled.

### To disable one or more keys:

1. Select the key(s) you want to disable.
2. Choose Enable Key from the Edit Menu or click the right mouse button on the key and choose Enable Key from the popup menu.

A red X appears on the key, indicating that it is disabled and the check mark is removed from Enable Key on the Edit menu.

### To enable a key:

1. Select the disabled key(s) that you want to enable.
2. Choose Enable Key from the Edit Menu or click the right mouse button on the key and choose Enable Key from the popup menu.

The red X is cleared from the key, and a check mark appears next to Enable Key on the Edit menu. If multiple keys are selected with some

keys enabled and others disabled, choosing the Enable Key command will enable all the selected keys.

## Opening a Saved Keypad Configuration

To open an existing keypad configuration file:

1. Choose Open from the File menu or click on the tool bar.

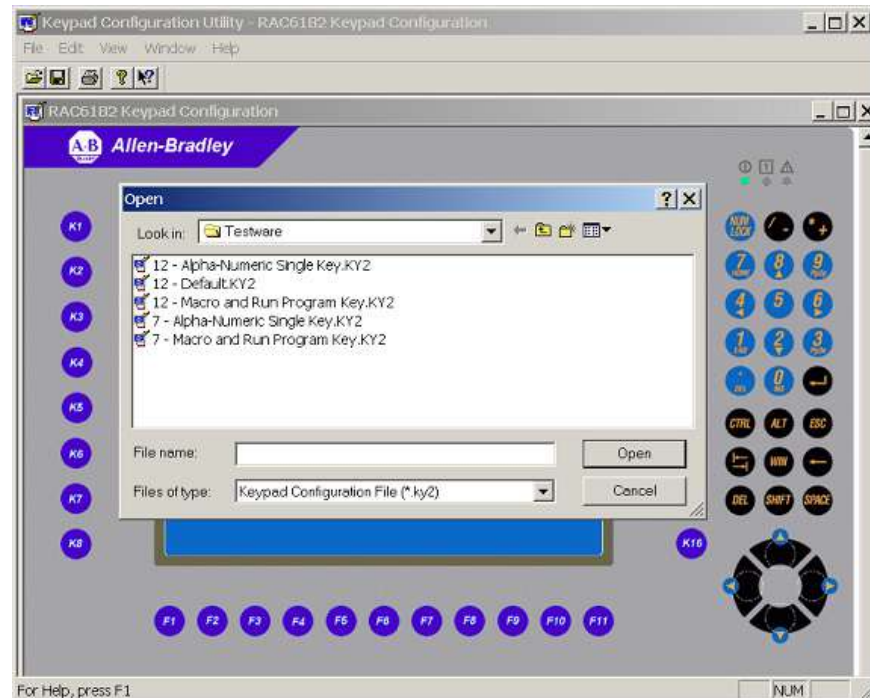

**Figure 4**  
**Open File**

2. The dialog shows all keypad configuration files (\*.KY2) in the “Look In:” folder.
3. Double-click the \*.KY2 file you want to open or click on a \*.KY2 file and then click the Open button. A window opens for the selected keypad configuration. The name of the \*.KY2 file shows in the title bar.

The window titled **RAC6182 Keypad Configuration** is the configuration stored on the RAC6182. If this window and all other keypad configuration windows are closed, you can reopen the RAC6182 Keypad Configuration from the File menu by selecting Open RAC6182 Keypad Configuration from the File menu.

## Set the Default Configuration for Programmable Keys

1. Select one or more programmable keys or use the edit menu Select All Programmable Keys. See “Selecting Keys” above.
2. Choose Set Default Configuration from the Edit menu.

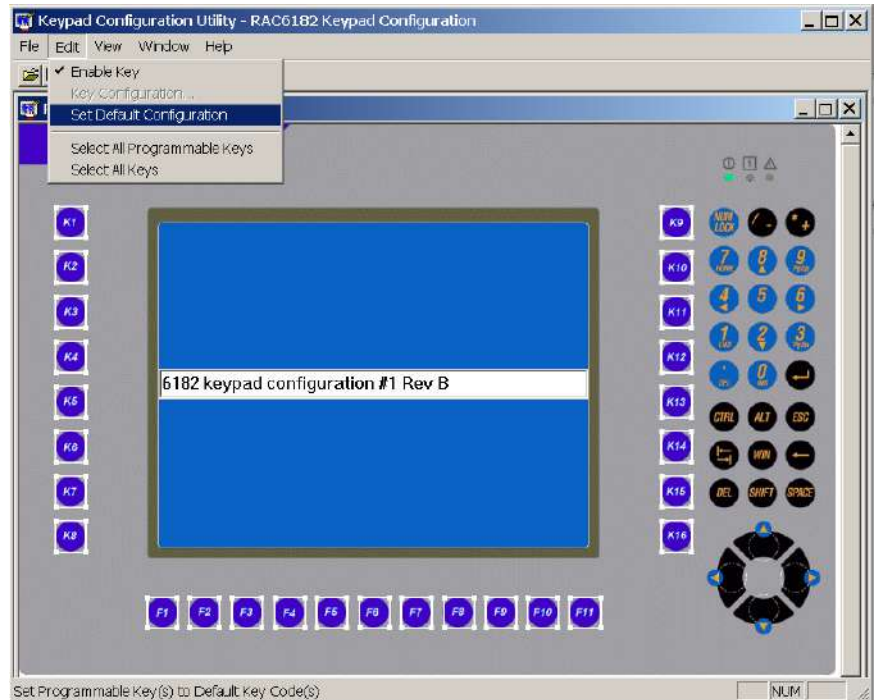
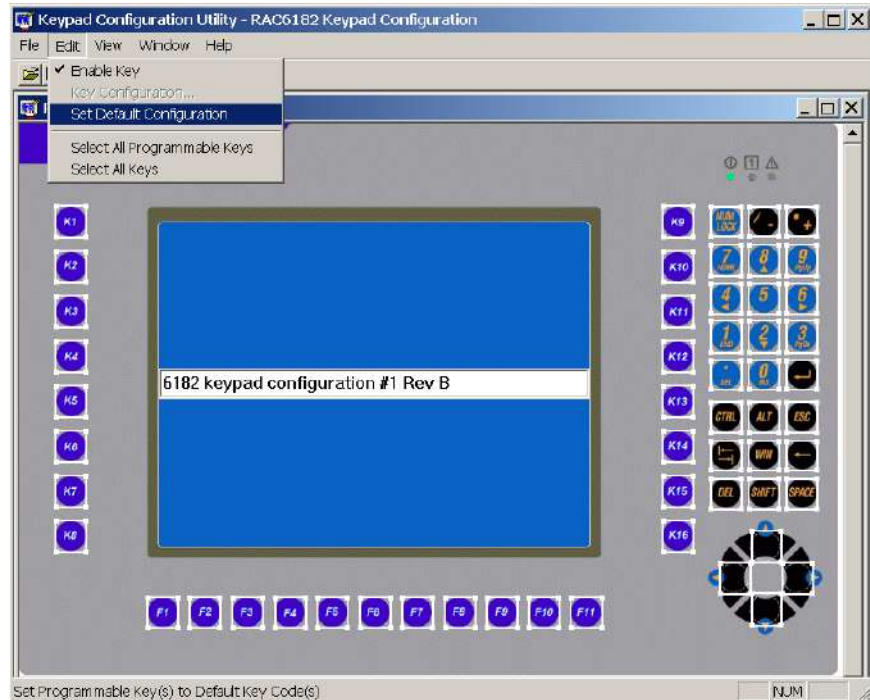

**Figure 5**  
**Set Programmable Key Default**

The selected programmable keys are set to their default assignments. The default key assignments are listed at the end of this chapter.

## Set the Default Configuration for Any Key

1. Select one or more keys or use the edit menu Select All Keys. See “Selecting Keys” above.
2. Choose Set Default Configuration from the Edit menu.



**Figure 6**  
**Set Key Default**

The selected keys are set to their default assignments. Non-programmable keys are enabled by default. The default key assignments are listed at the end of this chapter.

## Editing the Programmable Keys

To edit the definition of a programmable key:

1. Select a single programmable key.
2. Choose Key Configuration from the Edit menu or click the right mouse button on the key and choose Key Configuration from the popup menu as shown below.
3. Use the Edit Programmable Key dialog to view the current definition and establish a new definition for the programmable key.
4. Click OK or press Enter to save the definition and close the dialog.
5. When all programmable keys are defined to your satisfaction, download the Keypad Configuration to the RAC6182.

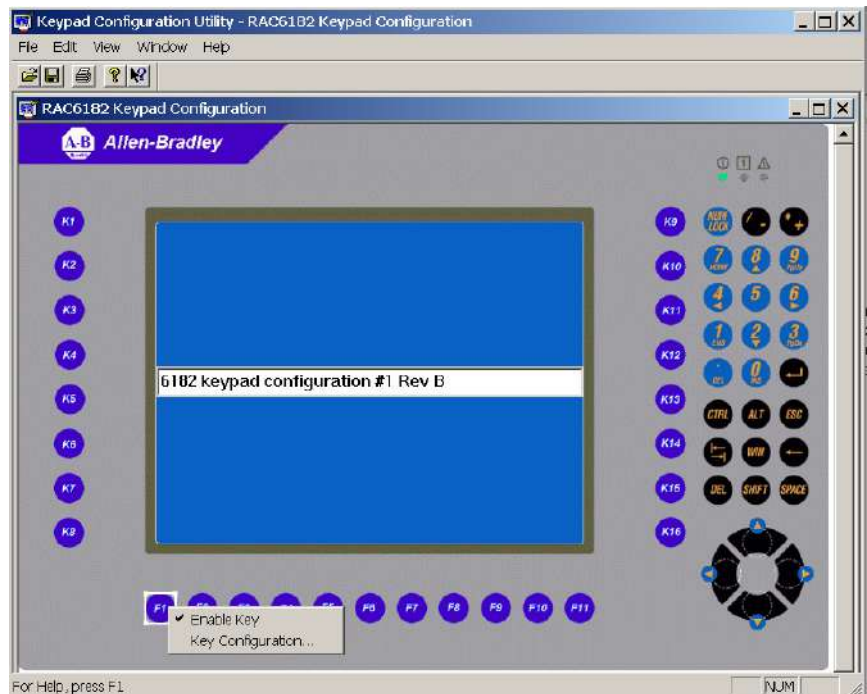

**Figure 7**  
Edit Configuration



The Edit Programmable Key dialog lets you modify the definition of the selected programmable key. The definitions are downloaded and stored in the registry of the RAC6182. Modifying a programmable key is not recommended unless required by the application software.

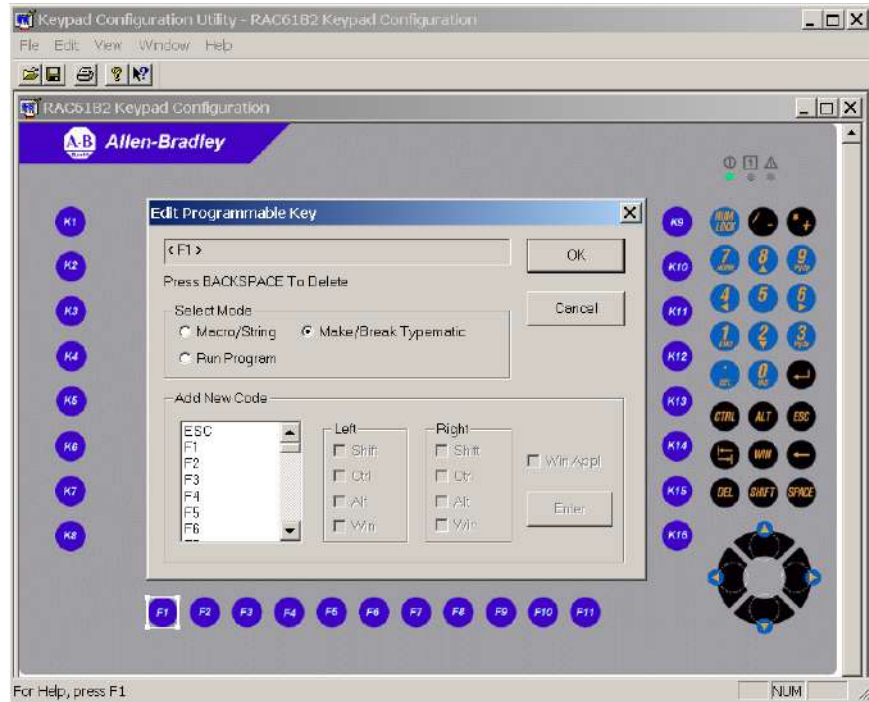

**Figure 8**  
**Select and Edit Programmable Key**

When the Edit Programmable Key dialog box opens, it shows the current definition of the selected programmable key. Nonprintable key codes appear in brackets, for example, <F1> or <(L)Shift+F1>. Modifiers appear to the left of a “+” symbol. (L) or (R) denote left or right modifier keys. The current mode is indicated in the Select Mode grouping.



## Text Edit Box

The text box at the top of the dialog displays the current definition for a selected programmable key. You can enter a new definition directly into the edit box if the characters are printable (e.g., alphanumeric characters). You must enter nonprintable characters from the Add New Code list. While in the text edit box, use Backspace to remove existing characters and correct typing errors. The contents of the Text Edit Box are transformed into key codes and/or run commands that are emitted when the key is pressed. Note that one of the more powerful RAC6182 keypad features is to perform multiple key codes with a single key press.

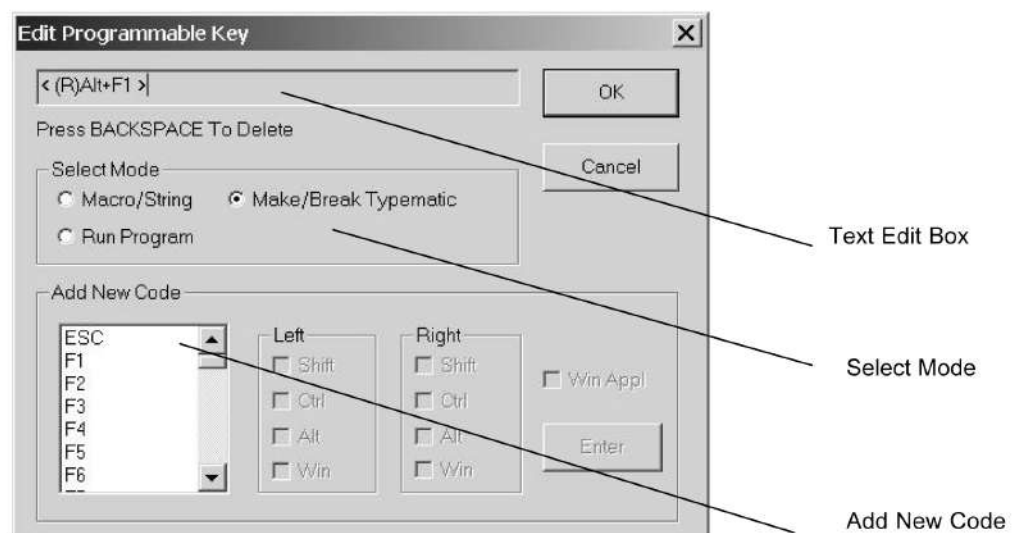

**Figure 9**  
**Edit Programmable Key Dialog**

## Select Mode

Determines how the contents of the Text Edit Box will be handled by the RAC6182 when the selected key is pressed. There are 3 modes, established by radio buttons.

1. In **Macro/String** mode, the key is defined as non-repeating and all key codes are sent as a single string when the key is first pressed. A key defined as a Macro/String can submit a sequence of up to 31 key presses to the application that is currently in focus.

In the following example, the programmable key emits the well-known, DOS “DIR command” to the command prompt. The RAC6182 command prompt application window must be “in focus” on the RAC6182 before this macro string will work. The command prompt can be opened from the Start menu: START / PROGRAMS / COMMAND PROMPT.

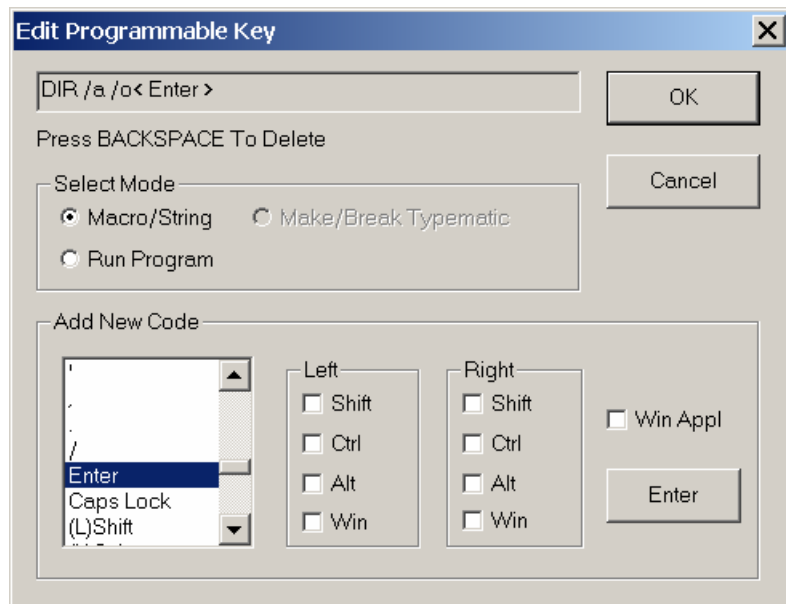
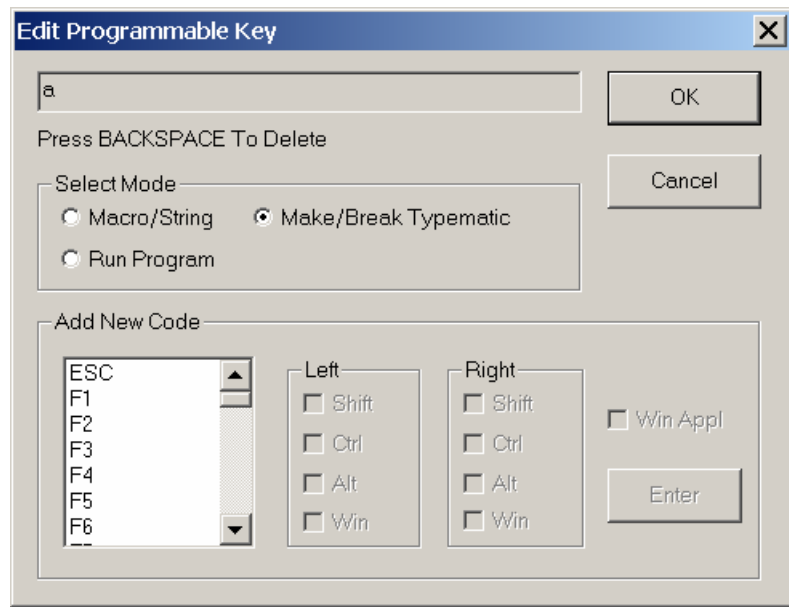

**Figure 10**  
**Macro/String Mode**

2. In **Make/Break Typematic** mode, the key is defined as repeatable at the Repeat Rate established by the Keypad Properties Tool in RAC6182 Control Panel. The key “Make” codes are sent when the key is first pressed and the “Break” codes are sent when the key is released. If the key is held down, the “Make” codes repeat at the Repeat Rate.

Make/Break Typematic mode is available only for a single key press definition including its modifiers, and as such is typically used to map a programmable key to a single alpha key. Thus the keypad can emulate a subset of a standard PC keyboard.

In the following example the programmable key emits the character ‘a’ at the Repeat Rate.



**Figure 11**  
**Make/Break Typematic Mode**

3. In **Run Program** mode, the key is defined as non-repeating, and all key codes are sent as a single string when the key is first pressed. A key defined as a Run Program can submit a sequence of up to 80 characters. Unlike the other modes, wherein actions are directed at the application with current focus, this action is directed at the operating system to run the program that is named in the Text Edit Box.

In the following example, the key press launches a program named “ProgramName.exe”. You cannot enter a path name in this field. You can only enter the program name. So either locate a shortcut to the application in the search path (defined below) or follow the directions below for adding search paths to the RAC6182 registry.

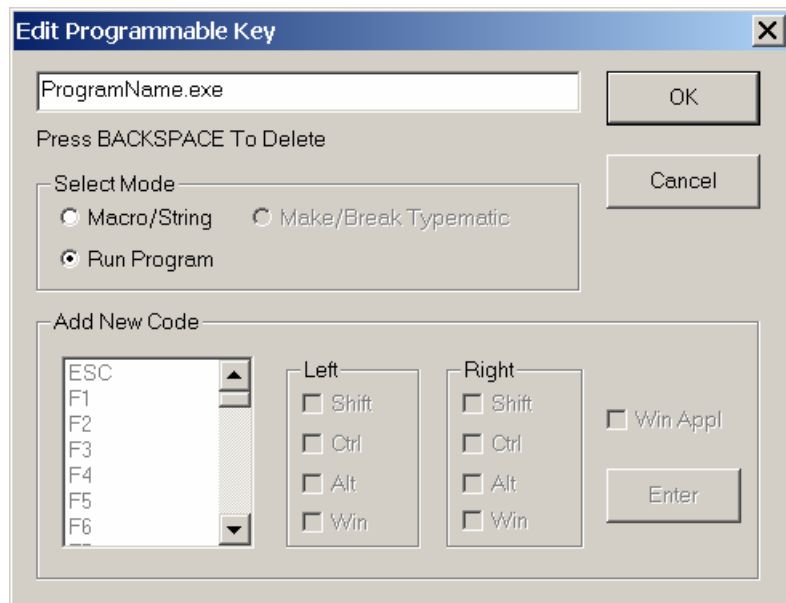

**Figure 12**  
**Run Program Mode**

A programmable key in the Run Program mode calls the Win32 API call CreateProcess() with the name of an executable program. Directories are searched in the following order:

1. The Windows (\windows) directory
2. The root (\) directory of the device
3. OEM specified directories as follows:

The registry subkey can specify a search path for the CreateProcess function:

```
\HKEY_LOCAL_MACHINE\Loader
  "SystemPath"=multi_sz: \\path1\ "\\path2\\"
```

## Add New Code

The **Add New Code** grouping on the dialog is a list of valid keys and modifiers that can be assigned to a programmable key. A modifier (Shift, Ctrl, Alt, Win or Win Appl) are enabled for a key code, by selecting the appropriate check boxes. These check boxes are dynamically updated so that only valid combinations are allowed. After selecting a key code and modifiers, click the Enter button to display the new code in the Text Edit box. You must click Enter after each new code selection. Non-printable codes are enclosed within '<' and '>'.

### Hints for editing a programmable key definition:

- Select (or click on) a code in the Add New Code list.
- Under Left or Right, select the Shift, Ctrl, Alt, or Win check boxes to enable one or more modifiers for the new code.
- Click Enter to display the new code in the text box. If entering multiple codes, click Enter after each code selection or double-click each code selection. The text box is automatically updated.
- Type the characters in the Text box as you want them to appear using shifted or unshifted characters.
- To insert a nonprintable code in the text, select the code from the Add New Code list and then click Enter. The nonprintable code is inserted in the text with brackets.

## Examples of Editing Key Definitions

### Example #1: Configure the K1 key as < (L)Win+e > which runs Windows Explorer:

1. Select the key labeled K1.
2. Choose Key Configuration from the Edit menu, or click the right mouse button on the key and choose Key Configuration from the popup menu.
3. In the text box, backspace to delete the current definition.
4. Under Select Mode, select Make/Break Typematic.
5. Select 'e' from the Add New Code list.
6. Under Left, check Win check box.
7. Click the Enter button to display the new definition.

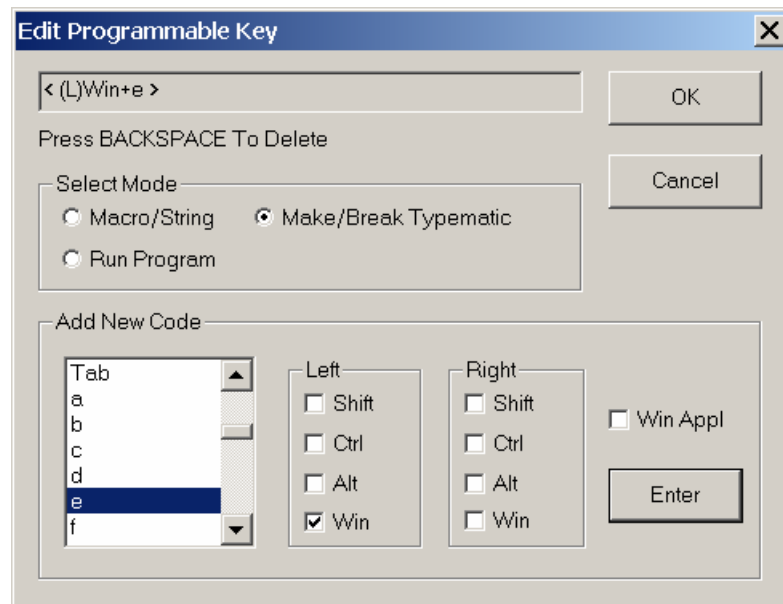
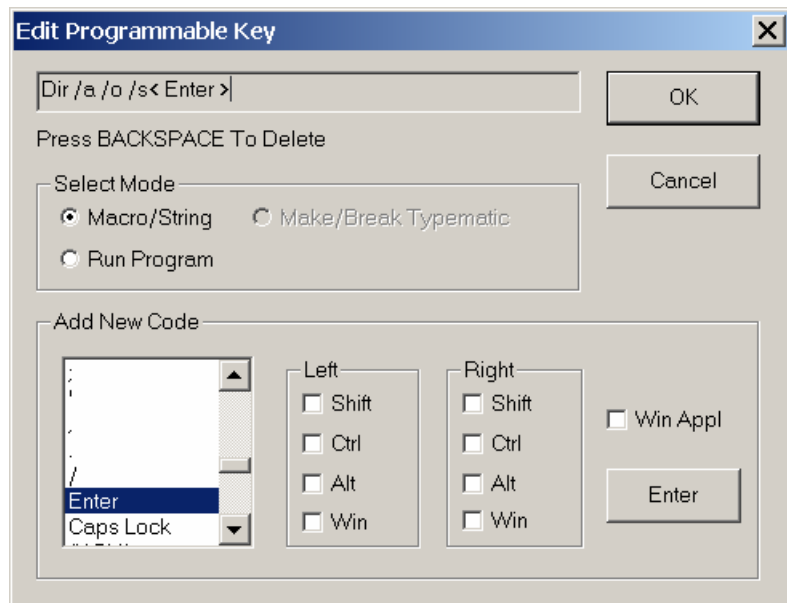

**Figure 13**  
**Example #1**

8. Click OK to store the definition and exit the dialog.

**Example #2: Configure the K10 key perform a DIR /a /o /s command**

1. Select the key labeled K10.
2. Choose Key Configuration from the Edit menu, or click the right mouse button on the key and choose Key Configuration from the popup menu.
3. In the text box, backspace to delete the current definition
4. Under Select Mode, select Macro/String
5. In the text box, type DIR /a /o /s
6. In the Add New Code list, select Enter and click the Enter button

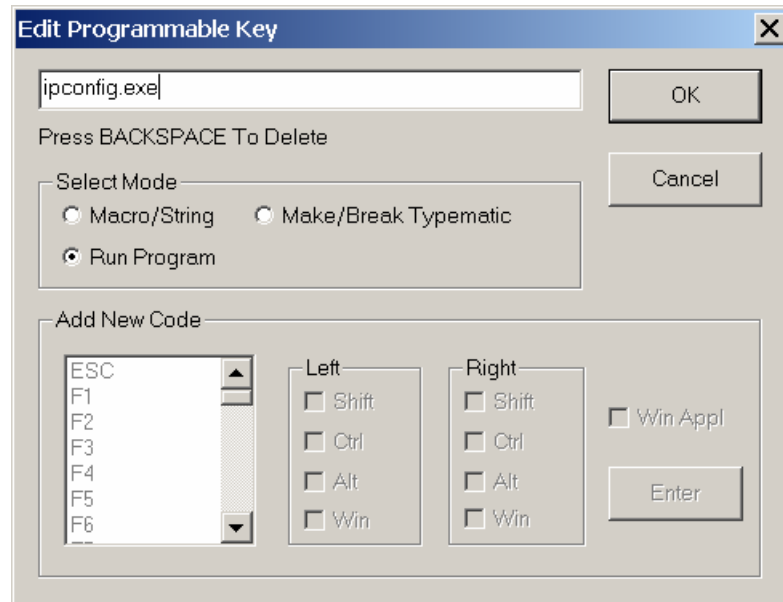

**Figure 14**  
**Example #2**

7. Click OK to store the definition and exit the dialog.

**Example #3: Configure the F6 key to run the program IPCONFIG.EXE**

1. Select the key labeled F6.
2. Choose Key Configuration from the Edit menu, or click the right mouse button on the key and choose Key Configuration from the popup menu.
3. Under Select Mode, Run Program.
4. In the text box, type “ipconfig.exe”



**Figure 15**  
**Example #3**

5. Click OK to store the definition and exit the dialog.



## Saving Keypad Configurations

You can save a keypad configuration under the existing name or under a new name.

### Save

Choose Save from the File menu or click on the tool bar to save changes to a keypad configuration under the current name. The default filename for the keypad configuration is RAC6182.KY2. The first time you try to save a configuration, the Save As dialog opens.

### Save As

Choose Save As from the File menu to save the keypad configuration under a new file name. The default file type for a RAC6182 keypad configuration files is \*.KY2.

## Previewing and Printing a Keypad Report

The RAC6182 Keypad Configuration Utility creates a printed report for each Keypad Configuration. You can print the report or preview the report first and then print it. Print Preview is a convenient way to view the keypad configuration.

### To preview a keypad configuration:

1. Open the \*.KY2 keypad configuration file you want to preview.
2. Choose Print Preview from the File menu.

The Preview workspace opens showing the keypad report. The report includes:

- Keypad configuration file name \*.KY2, or “RAC6182 Keypad Configuration” if the keypad configuration is from the RAC6182.
- Date/time report generated.
- Description field of the keypad configuration.
- List of Non-programmable keys (enabled or disabled) on Page 1.
- Definitions of programmable keys (enabled or disabled), and whether the key definition is Macro/String, Make/Break Typematic or Run Program on Page 2.

Macro/String definitions appear in double quotes; e.g. “String”.  
Make/Break Typematic definitions appear in single quotes; e.g. ‘a’.  
Run Program definitions appear within braces; e.g. {Program Name}. Disabled keys appear with a line through the key name and definition.

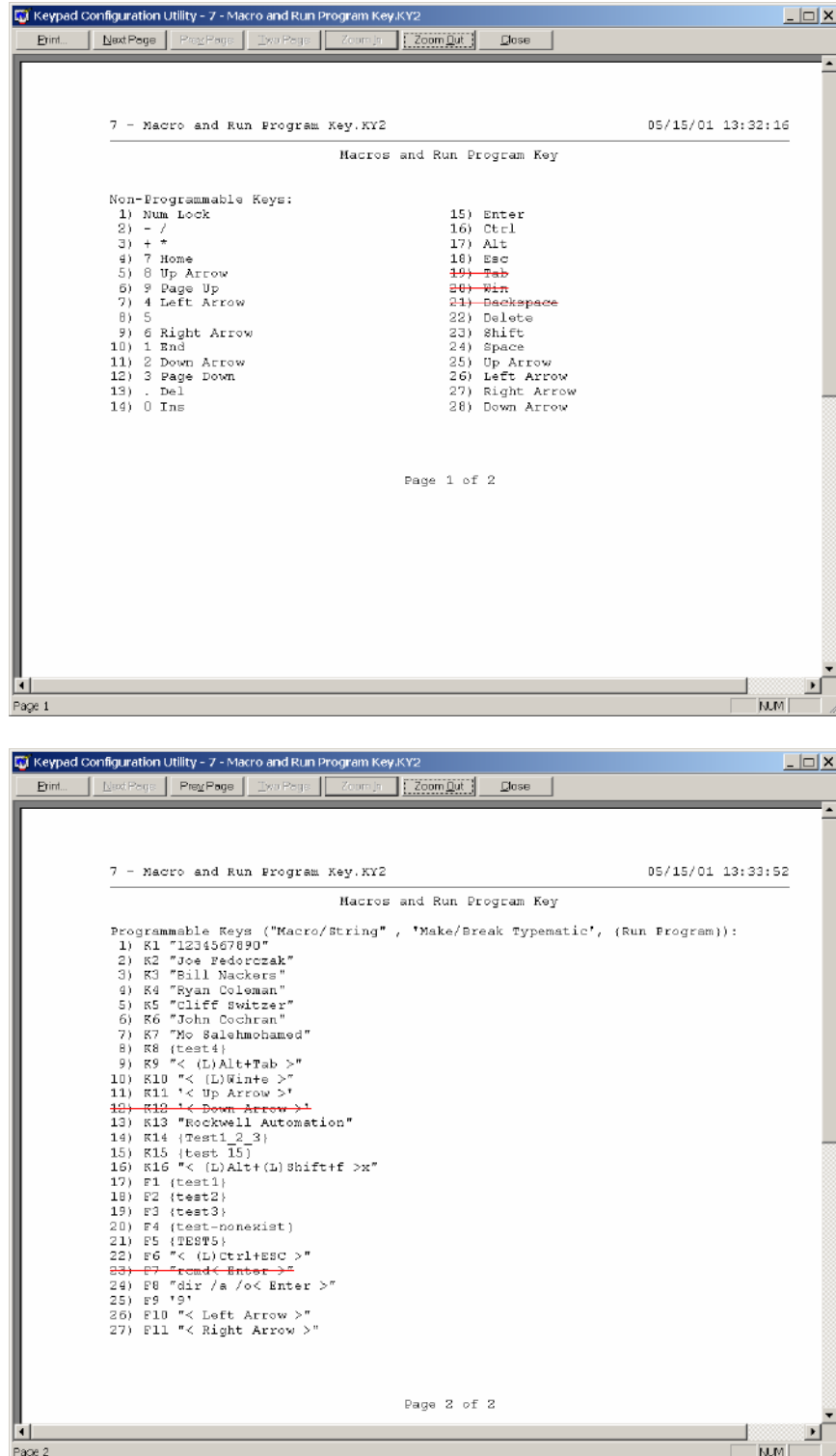

**Figure 16**  
Print Preview

3. Select one of the buttons at the top of the workspace.

Click this button:	To:
Print	Open a Print dialog allowing you to print the report. See the next page.
Zoom In	Increase the magnification of the view so the report looks larger. You can increase the magnification several times.
Zoom Out	Decrease the magnification of the view so the report looks smaller. You can decrease the magnification several times.
Close	Exit the Preview workspace.

## Downloading a Keypad Configuration to the RAC6182

### To download a keypad configuration to the RAC6182:

1. The active window must contain the keypad configuration you want to download to the RAC6182.
2. From the File menu, choose Download Keypad configuration to RAC6182.... A dialog opens asking you if you want to replace the current contents of the RAC6182 with the contents of the active window.

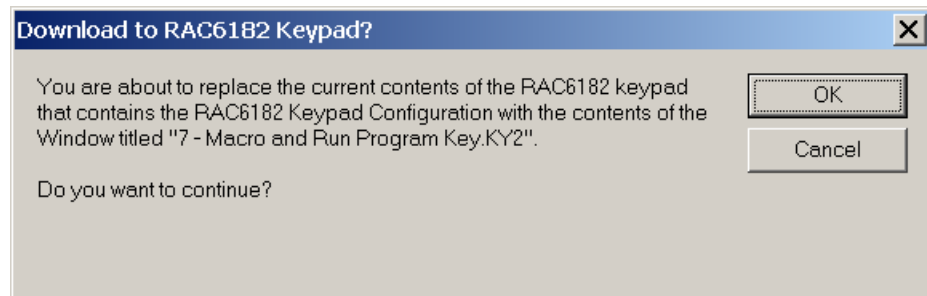

**Figure 17**  
**Download**

3. Click OK to continue with the download.

## 7.7 in. Keypad Default Key Assignments for Programmable Keys

RA=Right Alt Key, RS = Right Shift Key, VK = Virtual Key

Key Legend	Default Key Assignments	Make Key Codes (Key Pressed)	Break Key Codes (Key Released)
F1	VK_F1	0x70	0x70
F2	VK_F2	0x71	0x71
F3	VK_F3	0x72	0x72
F4	VK_F4	0x73	0x73
F5	VK_F5	0x74	0x74
F6	VK_F6	0x75	0x75
F7	VK_F7	0x76	0x76
F8	VK_F8	0x77	0x77
F9	VK_F9	0x78	0x78
F10	VK_F10	0x79	0x79
F11	VK_F11	0x7a	0x7a
K1	RA + VK_F1	0x12, 0x70	0x12, 0x70
K2	RA + VK_F2	0x12, 0x71	0x12, 0x71
K3	RA + VK_F3	0x12, 0x72	0x12, 0x72
K4	RA + VK_F4	0x12, 0x73	0x12, 0x73
K5	RA + VK_F5	0x12, 0x74	0x12, 0x74
K6	RA + VK_F6	0x12, 0x75	0x12, 0x75
K7	RA + VK_F7	0x12, 0x76	0x12, 0x76
K8	RA + VK_F8	0x12, 0x77	0x12, 0x77
K9	RA + VK_F9	0x12, 0x78	0x12, 0x78
K10	RA + VK_F10	0x12, 0x79	0x12, 0x79
K11	RA + VK_F11	0x12, 0x7a	0x12, 0x7a
K12	RA + VK_F12	0x12, 0x7b	0x12, 0x7b
K13	RS + VK_F1	0x10, 0x70	0x10, 0x70
K14	RS + VK_F2	0x10, 0x71	0x10, 0x71
K15	RS + VK_F3	0x10, 0x72	0x10, 0x72
K16	RS + VK_F4	0x10, 0x73	0x10, 0x73

## 12.1 in. Keypad Default Key Assignments for Programmable Keys

RA=Right Alt Key, RS = Right Shift Key, VK = Virtual Key

Key Legend	Default Key Assignments	Make Key Codes (Key Pressed)	Break Key Codes (Key Released)
F1	VK_F1	0x70	0x70
F2	VK_F2	0x71	0x71
F3	VK_F3	0x72	0x72
F4	VK_F4	0x73	0x73
F5	VK_F5	0x74	0x74
F6	VK_F6	0x75	0x75
F7	VK_F7	0x76	0x76
F8	VK_F8	0x77	0x77
F9	VK_F9	0x78	0x78
F10	VK_F10	0x79	0x79
F11	VK_F11	0x7a	0x7a
F12	VK_F12	0x7b	0x7b
F13	LS + VK_F1	0x10, 0x70	0x10, 0x70
F14	LS + VK_F2	0x10, 0x71	0x10, 0x71
K1	RA + VK_F1	0x12, 0x70	0x12, 0x70
K2	RA + VK_F2	0x12, 0x71	0x12, 0x71
K3	RA + VK_F3	0x12, 0x72	0x12, 0x72
K4	RA + VK_F4	0x12, 0x73	0x12, 0x73
K5	RA + VK_F5	0x12, 0x74	0x12, 0x74
K6	RA + VK_F6	0x12, 0x75	0x12, 0x75
K7	RA + VK_F7	0x12, 0x76	0x12, 0x76
K8	RA + VK_F8	0x12, 0x77	0x12, 0x77
K9	RA + VK_F9	0x12, 0x78	0x12, 0x78
K10	RA + VK_F10	0x12, 0x79	0x12, 0x79
K11	RA + VK_F11	0x12, 0x7a	0x12, 0x7a
K12	RA + VK_F12	0x12, 0x7b	0x12, 0x7b
K13	RS + VK_F1	0x10, 0x70	0x10, 0x70
K14	RS + VK_F2	0x10, 0x71	0x10, 0x71
K15	RS + VK_F3	0x10, 0x72	0x10, 0x72
K16	RS + VK_F4	0x10, 0x73	0x10, 0x73
K17	RS + VK_F5	0x10, 0x74	0x10, 0x74
K18	RS + VK_F6	0x10, 0x75	0x10, 0x75
K19	RS + VK_F7	0x10, 0x76	0x10, 0x76
K20	RS + VK_F8	0x10, 0x77	0x10, 0x77



## Display Settings

### Chapter Objectives

This chapter describes how to use the RAC6182 Display application to control the appearance of the Desktop and application windows in Windows CE, and to adjust the display.

### Setting Up the Display

You configure the RAC6182 Industrial Computer display using the Display application in the Windows CE Control Panel.

#### To set up the display:

1. To start the Display application, select Start-Settings-Control Panel. Select or double-click on the Display icon.

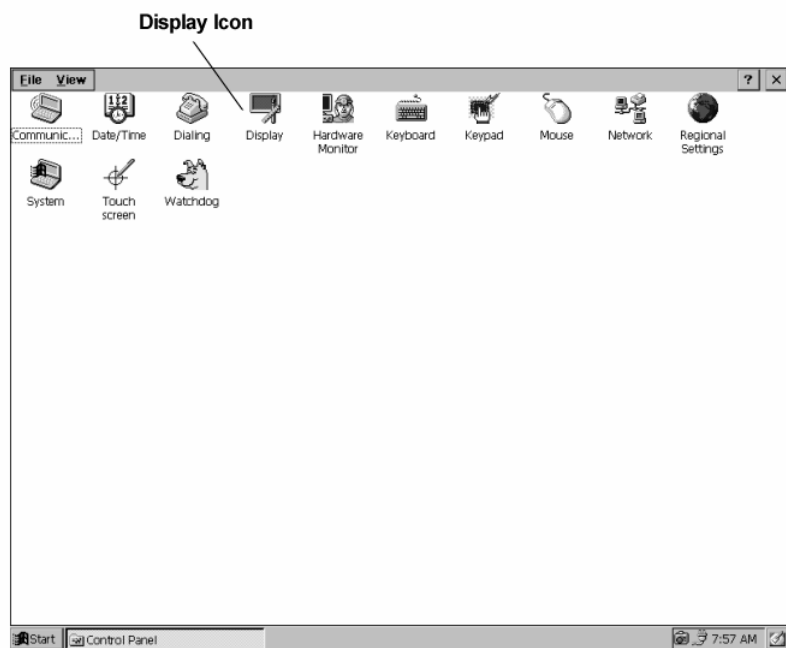

- On the Background tab of the Display Properties dialog, select a graphic to be displayed on the Windows CE Desktop.

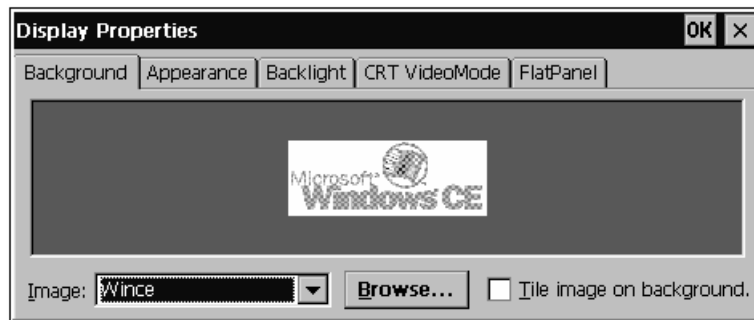

- On the Appearance tab, change the color scheme used for Windows CE.

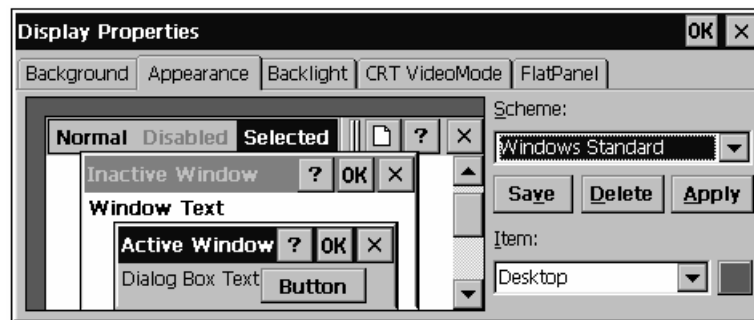

- On the Backlight tab, specify the length of time after which the RAC6182 Industrial Computer turns off the backlight when it is not needed.

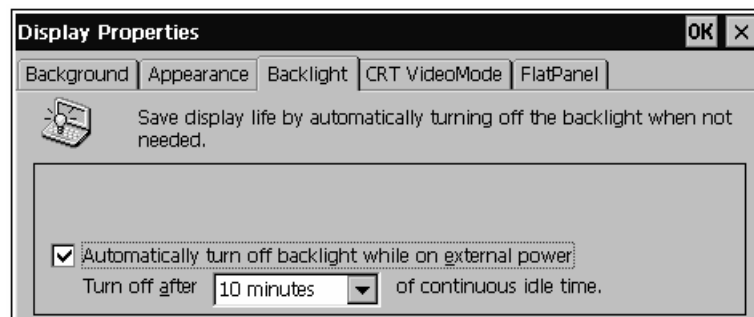



5. On the CRT Video Mode tab, specify the video resolution and refresh rate for an external monitor connected to the RAC6182 Industrial Computer. For versions of the RAC6182 with an integral display, the external video is fixed to the resolution on the internal LCD panel.

For the non-display RAC6182, the resolutions can be selected. They include:

640x480 VGA

800x600 SVGA

1024x768 XVGA



6. On the Flat Panel tab, adjust the contrast level and brightness level of the flat panel display on RAC6182 Industrial Computer, if applicable to this unit.

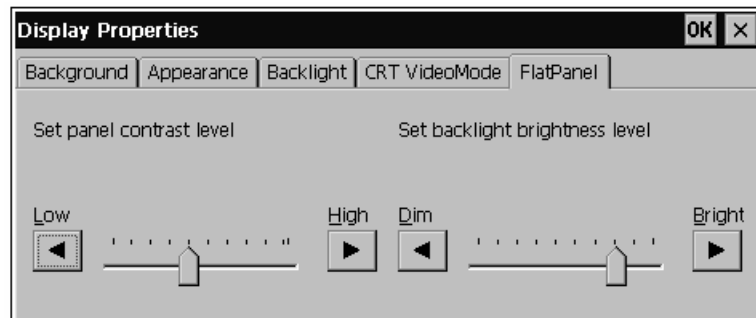

7. Press Enter or click the OK button to save the settings and exit.



## Touchscreen Calibration

### Chapter Objectives

This chapter describes how to use the RAC6182 Touchscreen application to calibrate the RAC6182 Industrial Computer touchscreen.

### Setting Touchscreen Properties

The RAC6182 touchscreen is factory-calibrated. However, it may be necessary to periodically recalibrate the touchscreen to adjust for any drift in the pointer. To recalibrate the touchscreen, you touch targets displayed by the calibration.

Touching the display with a finger is sufficient to perform the calibration process; however, you can use a stylus to increase the accuracy of the calibration. Do not use a sharp instrument or any pointing device that may puncture or damage the RAC6182 touchscreen overlay material.

You calibrate and configure the touchscreen using the Touchscreen application in the Windows CE Control Panel.

#### To calibrate the touchscreen:

1. To set up the touchscreen, select Start-Settings-Control Panel. Select or double-click on the Touch Screen icon.

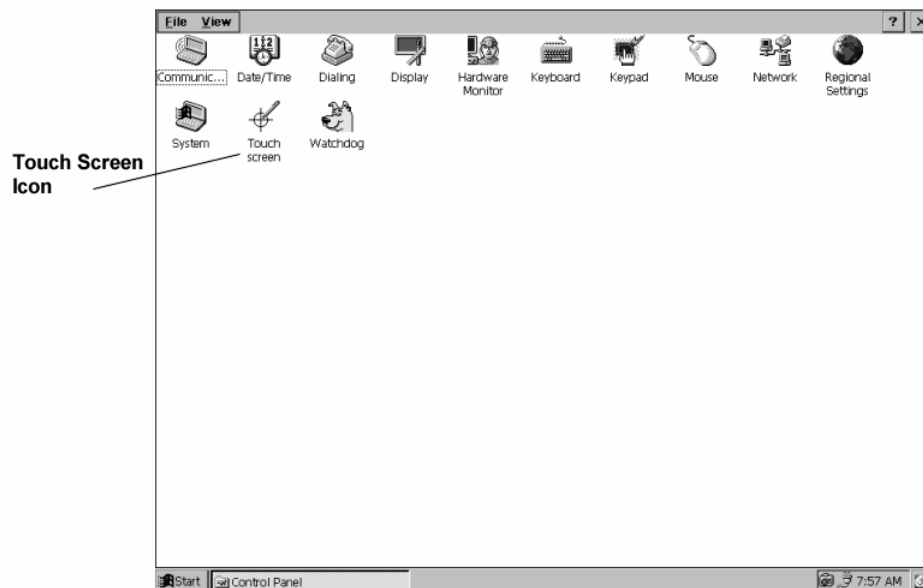

2. On the Calibration tab, select the Recalibrate button and touch the screen in the target areas as prompted by the application.

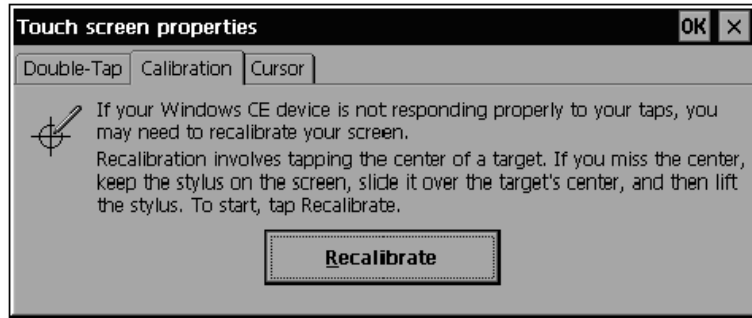

3. Press Enter or click the OK button to save the settings and Exit.

#### To set the double-tap (double-click) settings:

When using a touchscreen, you may be required to "double-tap" the touchscreen to respond to the application. The Touchscreen application allows you to adjust the rate at which the screen must be tapped to perform a double-tap.

1. On the Double-Tap tab, tap twice quickly on the grid pattern on the window to perform a double-tap.

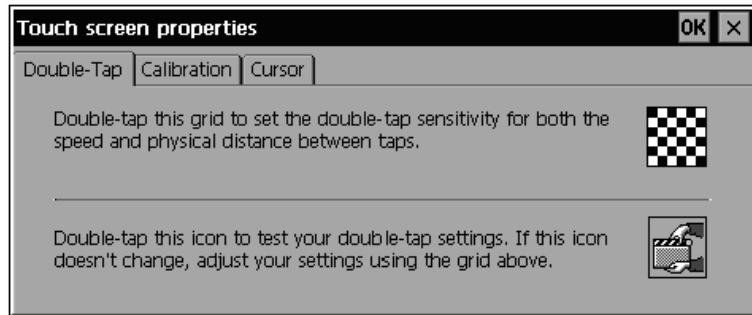

2. Double-tap the second icon to test the double-tap speed and accuracy.
3. Press Enter or click the OK button to save the settings and Exit.

**To disable the mouse cursor:**

On RAC6182 Industrial Computers with a touchscreen, you may want to disable the mouse and remove the mouse cursor from the screen. You can use either the Touchscreen application or the Control Panel Mouse application to change this setting.

1. On the Cursor tab, clear the Enable Cursor checkbox to disable the mouse and remove the mouse cursor.

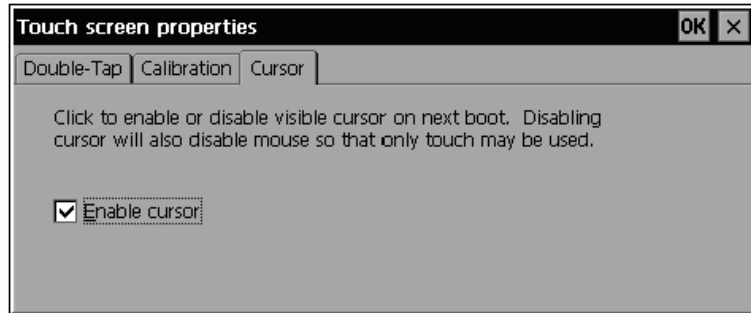

2. Press Enter or click the OK button to save the settings and Exit.

You must turn off power to the RAC6182 Industrial Computer for this setting to take effect.



## Hardware Monitor

### Chapter Objective

This chapter describes how to use the RAC6182 Hardware Monitor application to do the following:

- Monitor the internal bus voltages and temperature
- Reset the Diagnostics LED
- View the Event Log.

### Hardware Monitor System Software

The RAC6182 Hardware Monitor consists of a system software application and a Control Panel user interface. The Hardware Monitor system software continuously monitors the RAC6182 computer's internal 3.3V, 5V, and 12V power supply voltages, the 3V battery voltage, and CPU board temperature.

If any of these diagnostic parameters exceed their preset limits, the Hardware Monitor will enter a time-stamped record of the event into the Event Log file. It will also turn on the front bezel Diagnostics LED, indicating that a warning event has occurred. The Diagnostics LED will remain lit until manually reset using the Hardware Monitor Control Panel interface, even if the parameter returns to normal limits. There is a 500msec delay period between a warning event and its being recognized, to "debounce" any boundary conditions and avoid spurious warnings from being logged.

### Enabling the Hardware Monitor

When shipped from the factory, the RAC6182 Hardware Monitor system software is located at `\Storage Card\Platform\HWMonitor.exe`. A shortcut to `HWMonitor.exe` is also loaded into the `\Storage Card\Windows\StartUp` folder. The RAC6182 Computer is shipped with the Hardware Monitor disabled. Use the Hardware Monitor Control Panel interface to enable the Hardware Monitor. Once enabled, as long as the shortcut is in `\Storage Card\Windows\StartUp` folder, the Hardware Monitor will automatically start and run in the background every time the RAC6182 Computer powers up.

The first time the Hardware Monitor is enabled, it will create the Event Log file. This file is `\Storage Card\Platform\HWMonitorEvent.Log`, and will remain persistent through future disables and enables of the Hardware Monitor, unless manually cleared using the Hardware Monitor Control Panel interface. All diagnostic events are time-stamped and recorded in the Event Log file. The Event Log file contents can be viewed using the Hardware Monitor Control Panel interface.

## Using the Hardware Monitor

You access the RAC6182 Hardware Monitor using the Hardware Monitor interface in the Windows CE Control Panel.

### To access the RAC6182 Hardware Monitor:

1. To open the Hardware Monitor interface, select Start-Settings-Control Panel. Select or double-click on the Hardware Monitor icon.

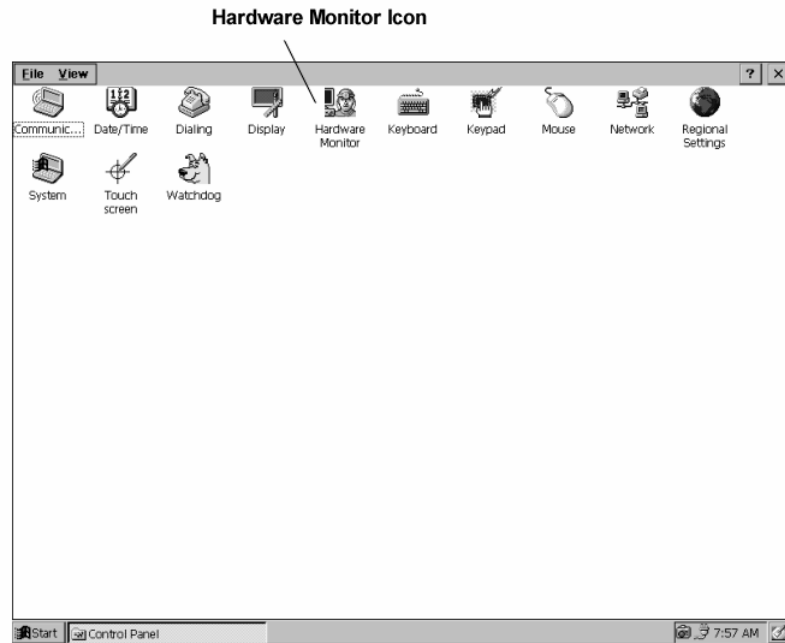

2. Select the Voltage and Temp tab to view the RAC6182 internal bus voltages, internal battery voltage (battery is for the clock/calendar and 128KB battery-backed SRAM), and the internal temperature.

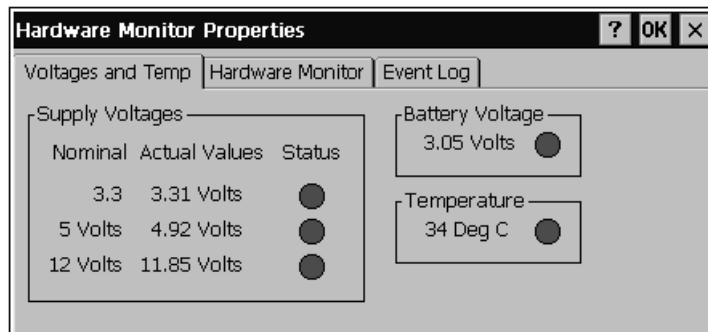

The voltage and temperature readings are updated in real time. The status icon next to each value is green if that parameter is within its limits, and red if the parameter is outside the preset limits. If outside of their preset ranges, then the red Diagnostics LED on the front bezel is also lit and will remain lit until reset manually.



**Note:** The temperature is measured on the CPU board, so it will be higher than the RAC6182 ambient operating temperature. The RAC6182 operating temperature rating is specified as ambient temperature outside the RAC6182 chassis, and internal temperature limits are set to compensate for expected heat-rise inside the chassis.

3. Select the Hardware Monitor tab to enable or disable the RAC6182 Hardware Monitor system software. Start the Hardware Monitor system software by clicking on the box to Enable, and clicking OK.

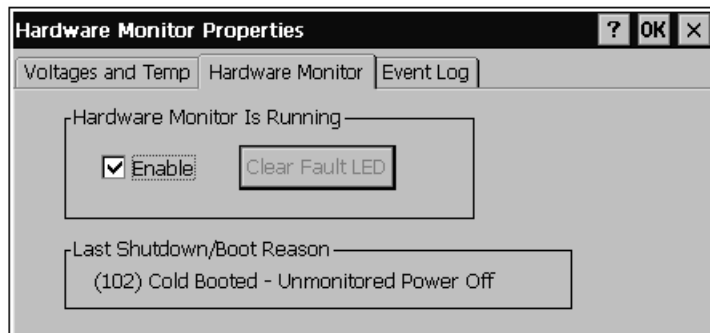

When enabled, the Hardware Monitor application automatically starts on power-up, as long as the shortcut remains in the *\Storage Card\Windows\StartUp* folder.

The Clear Fault LED button is used to turn off the front bezel Diagnostics LED. If any event occurs to turn on this LED, the LED remains lit even if the operating conditions return to normal.

The RAC6182 last shutdown/boot reason is listed on the bottom of this window.

4. Select the Event Log tab to view the Hardware Monitor's Event Log. All time-stamped diagnostic events, such as an over-temperature, under-voltage, or low-battery condition, are recorded in the Event Log. The Event Log is persistent through power cycles. You can also clear the event log by pressing the Clear Events button.

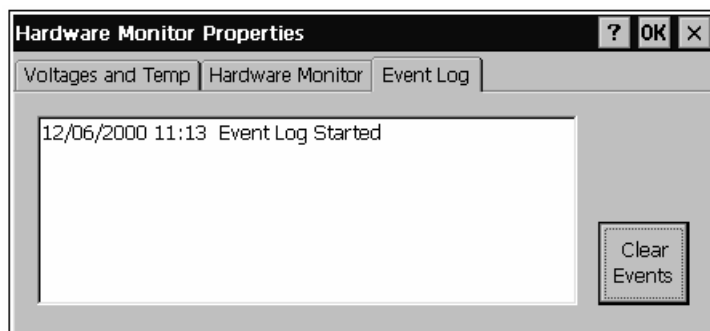



## Watchdog Timer

### Chapter Objective

This chapter describes how to use the RAC6182 watchdog timer to automatically reset the RAC6182 Computer in case of system lockup.

### Watchdog Functionality

The RAC6182 Industrial Computer has a built-in hardware timer that can be used to detect if the computer's processor locks up. To accomplish this, a software application is setup to restart the watchdog timer at regular intervals. If the system locks up, the application cannot restart the external watchdog timer, and the timer circuitry enters time-out mode and automatically resets the RAC6182 Industrial Computer.

### Simple Watchdog Implementation

The RAC6182 watchdog timer system software is a simple watchdog implementation, protecting against a catastrophic system lockup.

The RAC6182 watchdog timer application runs as a *normal* priority task in Windows CE. This application will continue to run in the background and restart the watchdog timer unless:

- The operating system itself locks up
- A higher priority task locks up (by entering infinite loop or having a memory error)

With a simple implementation, it is possible for an application with a low priority to lock up, or for two applications to reach deadlock without the watchdog timer being reset.

### Watchdog Control for Critical Applications

A critical control application or multitasking application may need to control the RAC6182 watchdog timer circuitry directly, to protect against system lockup. Software designers can utilize the watchdog API in their applications to restart the watchdog timer, instead of using the watchdog timer system software application.

If you integrate watchdog functionality in your application, do *not* enable the watchdog timer system software application provided with the RAC6182. Otherwise, the system software application may continue to restart the timer when your application is locked up.

Note also, that a watchdog timer only provides protection against system lockups. You may also need to consider other types of protection, such as a checksum, when designing critical applications.

## Using the Watchdog Timer System Software

The RAC6182 watchdog feature consists of a system software application and a Control Panel user interface.

### Setting the Watchdog Interval

The watchdog application allows you to specify the amount of time that can elapse before the system is reset. The watchdog interval can be set in 0.1 second increments from 0.5 to 4.0 seconds. The shorter the interval, the faster the RAC6182 Industrial Computer will be reset.

Choose the watchdog interval carefully. The Watchdog Timer application will consume more of the Windows CE operating system bandwidth to restart the watchdog timer if it is set to short intervals.

### Enabling the Watchdog Timer

When shipped from the factory, the watchdog timer system software application is disabled on the RAC6182 Industrial Computer. The watchdog timer application file is located at *\Storage Card\Platform\Watchdog.exe*.

A shortcut to *Watchdog.exe* is also loaded into the *\Storage Card\Windows\StartUp* folder. Once you enable the application, the shortcut starts the watchdog timer application when the RAC6182 Computer powers up.

#### To enable the watchdog timer:

1. To enable the watchdog timer, select Start-Settings-Control Panel. Select or double-click on the Watchdog icon.

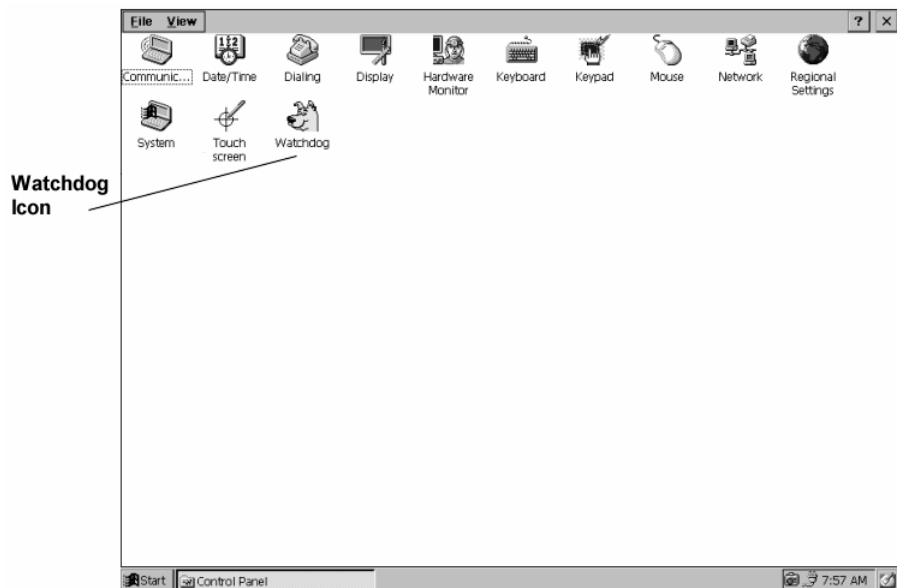

2. Select the Enable checkbox to turn on the watchdog timer software.
3. Select the desired watchdog timer interval using the slider control arrows. The interval can be from 0.5 to 4.0 seconds, in 0.1-second increments.

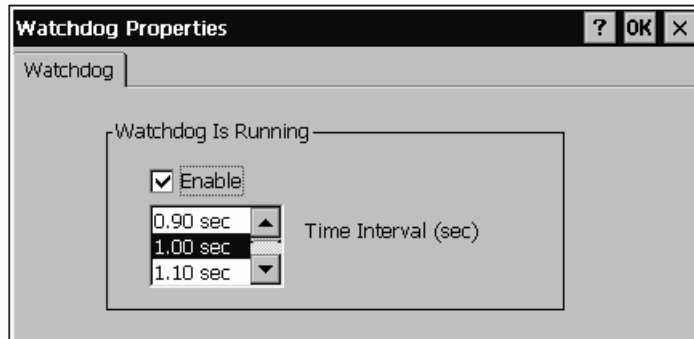

4. Press Enter or click the OK button to save the settings and exit.

The watchdog timer application automatically starts the next time you power-up the computer, as long as the shortcut remains in the *\Storage Card\Windows\StartUp* folder.

#### To disable the watchdog timer:

1. To disable the watchdog timer, select Start-Settings-Control Panel. Select or double-click on the Watchdog icon.
2. On the Watchdog Properties dialog box, clear the Enable check box.
3. Restart the RAC6182 Industrial Computer, and the watchdog timer application is disabled.



## Communications Configuration

### Chapter Objectives

This chapter describes how to configure the RAC6182 Industrial Computer to communicate with other computers using either the Ethernet connection or the serial connection. This chapter's topics include:

- Setting up Ethernet communications
- Setting up serial communications

### Setting Up Ethernet Communications

Setting up the RAC6182 Industrial Computer to communicate over an Ethernet network consists of two steps:

- Setting up the Ethernet configuration
- Setting up the RAC6182 Industrial Computer communications to use the Ethernet configuration

### Network Configuration

You configure communication over the Ethernet port using the Network application in the Windows CE Control Panel.

**To set up network configuration:**

1. To set up the network configuration, select Start-Settings-Control Panel. Select or double-click on the Network icon.

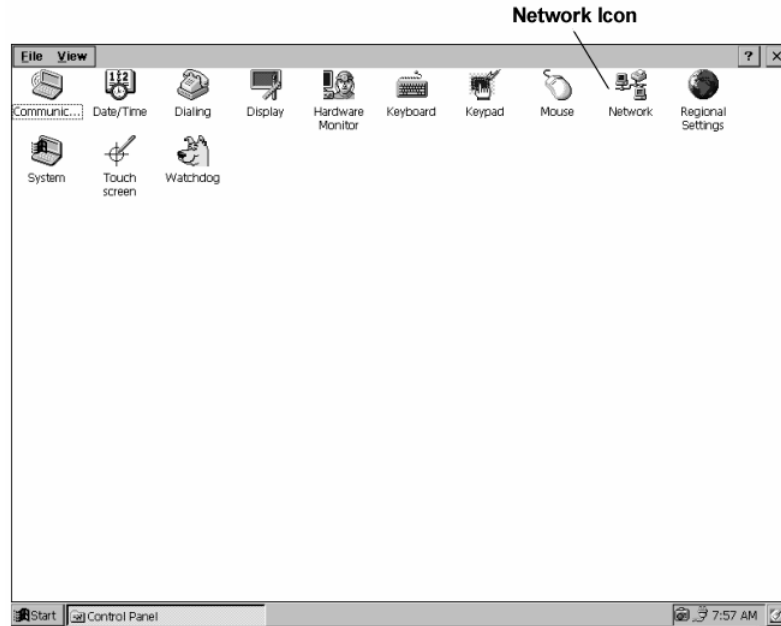

2. On the Adapters tab, select Intel 8255x Ethernet Chip from the list and select the Properties button.

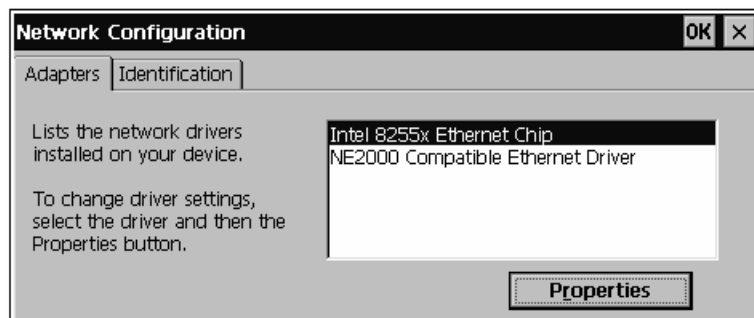



3. Complete the information on the IP Address and Name Server tabs as necessary for your Ethernet network.

**Intel 825x Ethernet Chip' Settings** [OK] [X]

IP Address | Name Servers

An IP address can be automatically assigned to this computer. If your network does not automatically assign IP addresses, ask your network administrator for an address, and then type it in the space provided.

Obtain an IP address via DHCP  
 Specify an IP address:

IP Address: 169 .254 .226 .105  
Subnet Mask: 255 .255 .0 .0  
Default Gateway: . . .

4. Press Enter or click the OK button to save the network settings and Exit.

## Communications Configuration for Ethernet

Once you have configured the Ethernet settings for your network, you must set the communications option for the RAC6182 to use the Ethernet connection and you must identify the host PC.

**Note:** To complete this process, you must know the IP address and host name that identifies the host PC on the network.

### To set up communications configuration for Ethernet:

1. To set up RAC6182 host communications, select Start-Settings-Control Panel. Select or double-click on the Communications icon.

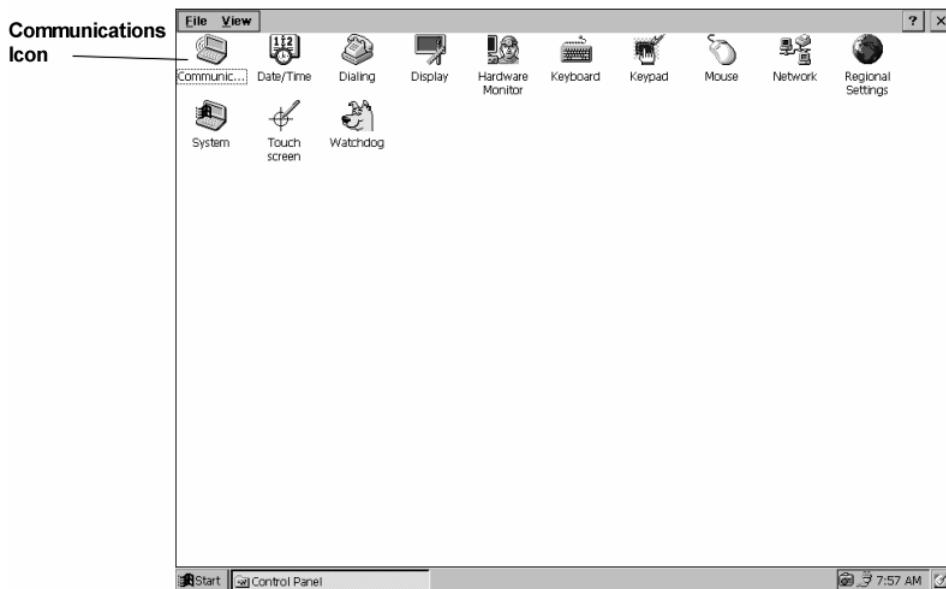

2. On the Device Name tab, enter the Device Name for the RAC6182 Industrial Computer. Optionally enter a description in the Device Description field. This information is used to identify the RAC6182 Industrial Computer to the host PC.

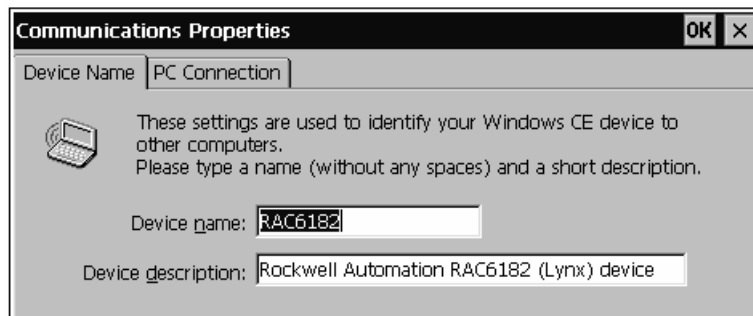

3. On the PC Connection tab, select the Change button.

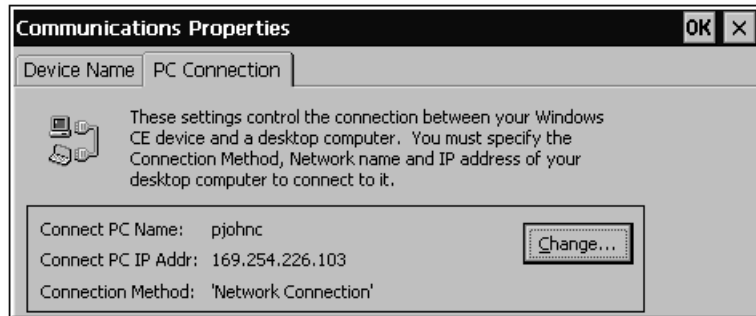

4. On the PC Connection Parameters dialog, specify the network host name for the host PC in the Connect PC Name field and specify the IP address for the host PC in the Connect PC IP Addr field.
5. Select Network Connection in the Connection Method field to specify that the RAC6182 should use the Ethernet network settings to connect to the host PC.
6. Press Enter or click the OK button on the PC Connection Parameters dialog to save the settings and Exit.
7. Press Enter or click the OK button on the Communications Properties dialog to save the settings and Exit.

For information on connecting to the host PC, refer to Chapter 15, Managing User Applications.

## Setting Up Serial Communications

Setting up the RAC6182 Industrial Computer to communicate over a serial port consists of two steps:

- Creating a remote networking connection for the serial port
- Setting up the RAC6182 Industrial Computer communications to use serial communications

## Remote Networking Connection

If you need to connect the RAC6182 Industrial Computer directly to a host PC using the serial port, you must first set up a remote networking connection.

### To set up a remote networking connection for serial communications:

1. Select Start-Programs-Communication-Remote Networking.
2. Select the Make New Connection icon.
3. Enter a name for the connection in the Name field and select the connection type. For serial connection to a host PC, select Direct Connection.
4. Select the device to use for this connection. For serial connection to a host PC, select Serial Cable on COM2.
5. Select Configure to set up the new connection. Specify the following information and select OK:

Field	Value
Baud Rate	Select desired baud rate
Data Bits	8
Parity	None
Stop Bits	1
Flow Control	Hardware

6. Select Finish.

Remote Networking creates the new connection.

## Communications Configuration for Serial Communications

Once you set up remote networking on the RAC6182 Industrial Computer, you must configure the RAC6182 to use your remote networking connection. You set up serial communications using the Communications application in the Windows CE Control Panel.

### To set up communications configuration for serial communications:

1. To set up RAC6182 host communications using serial communications, select Start-Settings-Control Panel. Select or double-click on the Communications icon.
2. On the Device Name tab, enter the Device Name for the RAC6182 Industrial Computer. Optionally enter a description in the Device

---

Description field. This information is used to identify the RAC6182 Industrial Computer to the host PC.

3. On the PC Connection tab, select the Change button.
4. Select the name of the remote networking connection you created previously in the Connection Method field. You do not need to specify a name or IP address on this tab.
5. Press Enter or click the OK button to save the communications settings and Exit.

For information on connecting to the host PC, refer to Chapter 15, Managing User Applications.



## Managing User Applications

### Chapter Objectives

This chapter describes how to set up a desktop computer to connect the RAC6182 Industrial Computer, how to transfer files between the computers, and how to manage user applications and data on the RAC6182 Computer. This chapter's topics include:

- Installing and using Microsoft ActiveSync on the host computer
- Installing and removing RAC6182 Computer applications
- Transferring files to and from the RAC6182 Computer
- Upgrading the RAC6182 Windows CE operating system

Before you can set up the host computer, you must connect the RAC6182 Industrial Computer to the host computer or network, and you must set up the communications configuration. For more information, refer to Chapter 3, Connecting External Devices, and to Chapter 13, Communications Configuration.

### Installing and Using Microsoft ActiveSync

Microsoft ActiveSync can be installed from the RAC6182 Applications and Accessories CD-ROM shipped with every RAC6182 Industrial Computer. ActiveSync is used to exchange data between a desktop PC and the RAC6182 Industrial Computer.

### ActiveSync Installation

Microsoft ActiveSync works with the following Microsoft operating systems: Windows 95, Windows 98, Windows NT, and Windows 2000. For detailed information on ActiveSync features, read the ActiveSync Help information once the program is installed.

#### To install Microsoft ActiveSync on a desktop PC:

1. Connect the RAC6182 Industrial Computer to a desktop PC serial port using a null modem cable (6189-2NMCBL).

**Note:** To complete the ActiveSync installation on a PC, you must connect the RAC6182 to the host PC using serial communications. Use a null modem cable attached to the COM2 port on the RAC6182.

After you install ActiveSync on the host PC, you can use either a serial communications or Ethernet communications to communicate with the RAC6182.

2. Apply power to both the host PC and the RAC6182 Industrial Computer.

3. Insert the RAC6182 Applications and Accessories compact disc into the desktop PC CD-ROM drive.
4. Open the *ActiveSync 3.0* folder on the CD-ROM and run the Setup application.
5. Follow the prompted messages displayed by the Microsoft ActiveSync Setup wizard. The wizard installs Microsoft ActiveSync, any required Windows components, and other optional applications for running a hand-held PC.
6. At the end of its installation process, Microsoft ActiveSync attempts to create a connection using the Get Connected wizard. The RAC6182 Industrial Computer must be connected and powered up for the connection wizard to work correctly. It automatically searches for any mobile devices connected to a serial or IR port.

While ActiveSync is searching for a connection, initiate the serial connection on the RAC6182 by running PC Link. It may take several attempts for PC Link and ActiveSync to establish a connection.

**Note:** For instructions on setting up communications, refer to “Setting Up Serial Communications” on page 13-5.

**Important:** To work properly, ActiveSync must make its first connection to an external device (immediately following installation) via a serial port. Once this connection is made, ActiveSync can connect to any external device via Ethernet.

**To create a connection between Microsoft ActiveSync and the RAC6182:**

If the wizard does not successfully create the connection, do the following:

1. Start ActiveSync on the host PC and follow the on-screen instructions until the Verify COM Port Availability window is displayed.
2. Check that the COM port is available. Select Next to try another search for a mobile device on a serial port.
3. Ensure that the serial cable is connected between the COM2 port and the desktop PC serial port.

**Note:** You **must** use the COM2 port on the RAC6182 to connect to ActiveSync using serial communications, and you **must** set up the PC connection on the RAC6182 with the COM2 direct connection.

4. On the RAC6182 Industrial Computer, select Start-Programs-Communication-PC Link.



PC Link attempts to establish a connection with the host computer using the connection method you set up.

5. ActiveSync starts the Get Connected wizard. Follow the wizard prompts to establish a connection with the RAC6182 Industrial Computer.
6. Once a connection is established, **do not** create a partnership between the PC and the RAC6182. Instead, initiate subsequent connections from the RAC6182 by selecting Start-Programs-Communication-PC Link.

### Additional Help on Microsoft ActiveSync

To get additional information on how to use Microsoft ActiveSync, see the online Help by selecting Microsoft ActiveSync Help from the Help menu. Help topics are available for set-up, usage, and troubleshooting information.

## Installing/Removing Applications on the RAC6182 Industrial Computer

There are at least three methods for installing a software application on the RAC6182 Industrial Computer. Each software application has its own defined installation process, so you should follow the installation instructions shipped with the software application.

- *ActiveSync* can be used to transfer a software application file from the desktop PC to the RAC6182 Industrial Computer. Once loaded, the application file can then be run on the RAC6182 Industrial Computer to install and register it with the RAC6182 Windows CE operating system.
- A *flash memory card* can be used to transfer a software application file into the RAC6182 Industrial Computer DOC flash memory (the *\Storage Card* folder on the RAC6182). Install the flash memory card in the RAC6182 PC card slot, and then open the flash card window (*\Storage Card2* or *\Storage Card3*). Copy the file into the DOC flash memory using Windows Explorer. Once transferred, the application file can be run to install and register the application with the Windows CE operating system.

**Note:** To install an application permanently into memory, you must ensure that the application is installed to the *\Storage Card* folder. Applications installed into the *\Program Files* folder are lost when power is cycled.

- The *software application* may provide a desktop PC program that automatically uses the ActiveSync connection to download and register the application to the RAC6182 Industrial Computer.

## Removing Applications

Most Windows CE applications loaded on the RAC6182 Industrial Computer should have an uninstall utility. Use the program's uninstall routine to remove it from the RAC6182. Failure to properly uninstall an application program may affect the Windows CE registry and cause unstable operation.

## Transferring Files To and from the RAC6182 Industrial Computer

There are at least three methods to transfer files to and from the RAC6182 Industrial Computer.

- ActiveSync can be used to move files between the desktop PC and the RAC6182 Industrial Computer. The files can be manually dragged between the PC and the RAC6182 Mobile Devices folder or its subfolders.
- Some software applications may have *proprietary file transfer features*. An application may support file transfers of the RAC6182 serial or network ports. Refer to the application's user manual for more information.
- A *flash memory card* can be used to manually transfer files to and from the RAC6182 Industrial Computer. When installed, a flash memory card appears as a separate "drive" within the Windows CE operating system environment. Files can be copied and moved between the flash memory card and the RAC6182 DOC flash memory.

## Upgrading the RAC6182 Windows CE Operating System

The RAC6182 Industrial Computer is shipped with the Microsoft Windows CE operating system preinstalled in the DOC flash memory.

Rockwell Automation will periodically distribute the RAC6182 Industrial Computer operating system upgrades as new features are released. These upgrades are distributed on CD-ROM. Upgrade procedures are on the CD-ROM.

Carefully read all documentation shipped with the RAC6182 Industrial Computer operating system upgrade. This documentation will outline any differences in the upgrade, and how installed application software may be affected by the new Windows CE version. It is very important to make sure all installed RAC6182 Industrial Computer applications are compatible with the new operating system.

## System Troubleshooting

### Chapter Objectives

This chapter describes the most common operating problems, the probable causes, and recommended corrective actions including:

- troubleshooting procedure
- troubleshooting checklists
- power on self test (POST) error messages
- general error and information messages
- resetting the Windows CE registry

### Hardware Diagnostics

The RAC6182 Industrial Computer monitors internal system voltages and the internal product temperature. If either of these diagnostic parameters fall out of tolerance, the red Diagnostics LED indicator on the front bezel is turned on.

Use the Hardware Monitor application to view diagnostic information and reset the Diagnostics LED. For more information, refer to Chapter 12, Hardware Monitor.

### Troubleshooting Procedure

To help identify and isolate a problem, we recommend that you do the following when a problem occurs:

1. Turn off the power to the RAC6182 Industrial Computer.
2. Disconnect all peripheral devices and remove all add-in PC and PCI cards.
3. Connect an external PS/2 keyboard and PS/2 mouse (if used) to the side panel connectors.
4. Check the video connections if using an external monitor.
5. Apply power and observe the LEDs on the front panel (if present). Make sure the power on indicator is illuminated.
6. Monitor the Power On Self Test (POST). One of the following will occur:

The RAC6182 Industrial Computer will successfully complete the boot-up process and start Windows CE.

The boot-up process will terminate (fatal error).

7. If the system boots up, isolate the problem by connecting peripheral devices one at a time until the problem occurs. If the problem is with a specific software package or driver, you may want to re-install the software.
8. If there is a problem not related specifically to a software installation or peripheral device, refer to the following troubleshooting checklists.

## Troubleshooting Check Lists

The following are checklists of items that you may have overlooked.

### **If you are having problems during boot-up:**

Are all connections secure?

Are the device drivers installed?

Are the jumpers on any add-in boards correctly positioned?

Is the RAM memory (DIMM) properly installed? You may want to re-install it to ensure a good connection.

Has the Windows CE operating system been upgraded? If so, make sure the procedure was successfully performed (refer to Chapter 15, Managing User Applications).

### **If there is a problem after boot-up:**

If you are running a software package, re-install the software.

If the problem is intermittent, you may have a loose connection. Check all connections including any add-in cards. Check that the memory module (DIMM) is fully installed.

Although the RAC6182 Industrial Computer has a regulated and protected power supply, a transient voltage in the power line or peripheral cable may cause a flickering display, unexpected reboots, or a locked up system. If so, exit the application and start over.

Is the system overheating? Look at the diagnostics light on the front panel display (if present). Verify that the enclosure is properly ventilated so the RAC6182 ambient operating temperature is within specifications.

**If there is a problem running new software:**

Does the software have a hardware requirement that is not present?

Are you using an authorized copy of the software? Some copies of software will not work without proper activation.

Did the software install correctly? Re-install the software.

Are you following the software's instructions? Refer to the software vendor's user manual.

**If there is a problem with an add-in board:**

Is the board installed and configured correctly? Recheck jumper and other configuration settings.

Are any cables correctly installed?

Are the Windows CE drivers loaded for the add-in board?

**If incorrect characters are displayed or are distorted:**

Are the display contrast and brightness controls properly adjusted? For information on configuring display settings, refer to Chapter 10, Display Settings.

Is the monitor compatible with the selected video mode? The 7.7-in. RAC6182 Industrial Computer LCD display is 640x480 (VGA) resolution. The 12.1-in. display is 800x600 (SVGA) resolution.

If using the integrated display, open the RAC6182 chassis and check the cable connections between the computer chassis and front bezel assembly.

**If characters are not displayed on an external monitor:**

Is the monitor functioning properly?

Is the video cable properly installed?

Check that selected character color is not set the same as the background color.

Is the video driver properly installed?

Reboot the RAC6182 Industrial Computer with the external monitor connected and powered up.

**If the Power On LED indicator does not come on:**

Check the power supply connections and front bezel cable connections on the processor board.

Check the power connections.



## Resetting the Windows CE Registry

The RAC6182 is capable of resetting the Windows CE registry to the factory default. This may be required if an application damages the registry information and the RAC6182 will no longer boot.

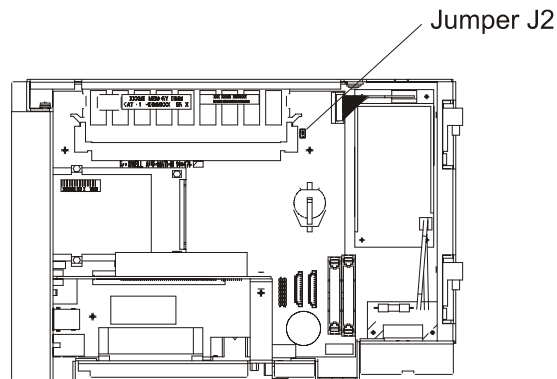
Jumper J2 on the RAC6182 CPU board is used to boot the RAC6182 Industrial Computer into debug mode, which will load the factory-default Windows CE registry.



**Jumper Settings:**

- |   |  |
|---|--|
|  | Debug Boot Operation<br>(Factory-Default Registry) |
|  | Normal Boot Operation<br>(Current Registry)        |

**To change the J2 jumper:**

1. Disconnect power from the RAC6182 Computer.
2. Disconnect any device connected to COM2 port.
3. Follow the procedures on Page 4-2 to open the computer chassis.

4. Locate jumper J2. The 2-pin jumper should be across pins 2 and 3 for normal operation.
5. Change the 2-pin jumper to connect pins 1 and 2.
6. Follow the procedures on Page 4-3 to close the computer chassis.

**To reset the Windows CE registry:**

1. Apply power to the RAC6182 Computer.

The computer boots into a debug mode. This mode performs a more extensive power-on self test (POST) procedure. It also reverts to the factory stored Windows CE registry. Finally, it enables a debug monitor output on COM2. The debug monitor is a Windows CE development tool feature for product development or debug purposes only.

2. After the RAC6182 Computer boots in debug mode, delete the previous registry files. Open Windows Explorer from Start-Programs-Windows Explorer or double-click the My Computer desktop icon.
3. Open the *\Storage Card* folder. From the View menu, select Options. Make sure the option is set to show all files.
4. Delete the following two files from *\Storage Card* folder:

*Regbak.rlz*

*Registry.rlz*

5. Disconnect power from the RAC6182 computer.
6. Follow the procedures on Page 4-2 to open the computer chassis.
7. Change the 2-pin jumper J2 back to connect pins 1 and 2 to restore normal operation.
8. Follow the procedures on Page 4-3 to close the computer chassis.
9. On the next power-up, the RAC6182 Computer boots in normal mode and uses the factory default registry information, stored in the boot block flash memory.

The *Regbak.rlz* and *Registry.rlz* files will be recreated when an item is changed that affects the registry, such as a Control Panel setting or installation of an application program. Otherwise, the RAC6182 continues to use the factory default registry information.





## Maintenance

### Chapter Objectives

This chapter describes routine maintenance procedures for:

- cleaning the display and front bezel
- replacing the battery

**Note:** Procedures for replacing the RAC6182 Industrial Computer backlight are in Chapter 5, Installing/Removing Front Bezel Assembly Items.

### Cleaning the Display

To clean the display:



**ATTENTION:** Use of abrasive cleansers or solvents may damage the display window. Do not scrub or use brushes.

---

1. Disconnect power from the RAC6182 Industrial Computer at the power source.
2. Using a clean sponge or a soft cloth, clean the display with a mild soap or detergent.
3. Dry the display with a chamois or moist cellulose sponge to avoid water spots.



**ATTENTION:** If the RAC6182 Industrial Computer has a touchscreen, be aware that it is possible for screen objects to activate during equipment wash-downs.

---

To remove paint and grease:

Remove fresh paint splashes and grease before drying by rubbing lightly with isopropyl alcohol. Afterward, provide a final wash using mild soap or detergent solution. Rinse with clean water.



**ATTENTION:** Make sure the isopropyl alcohol does not come in contact with the equipment labels.

Alcohol may cause the label printing to smear.

---

## Replacing the Battery

The RAC6182 Industrial Computer contains a battery to maintain the CMOS SRAM and real-time clock. The battery is located in a battery holder on the RAC6182 Industrial Computer backplane. Replace this battery as needed with a Panasonic battery, part number CR2032, or Allen-Bradley part 6189-1BATT.



**ATTENTION:** There is a danger of explosion if the battery is incorrectly replaced. Replace only with the same or equivalent type recommended by the manufacturer. Dispose of used batteries according to the manufacturer's instructions.

The RAC6182 Industrial Computer contains a super-capacitor in parallel with the battery. In the event that the battery dies, this capacitor will hold the RAM and clock for a minimum of 4 hours, up to a maximum of 8 hours based on battery age and RAC6182 operation. It also maintains the RAM and clock setting while the battery is removed and replaced. Power down the RAC6182 Industrial Computer before changing the battery.

The battery life is dependent on the amount of on-time per week. Estimated life of the battery is listed below:

On-Time	Expected Battery Life
0 hours/week	4 years
40 hours/week	5.5 years
80 hours/week	7 years

## Restoring the RAC6182 Industrial Computer

If a complete system failure occurs, use the following procedures to restore the RAC6182 Industrial Computer to its factory configuration.

1. Delete all files in the *\Storage Card* folder. Make sure to delete all hidden files and folders.
2. Use the instructions in Chapter 16, System Troubleshooting, to reset the RAC6182 Windows CE registry to its factory default.
3. The RAC6182 operating system is stored in a protected segment on the DiskOnChip flash memory. You should not need to reinstall the operating system. However, if you feel it necessary, use the instructions in Chapter 15, Managing User Applications, to reload the RAC6182 Windows CE operating system.

4. The RAC6182-specific files that need to be reloaded into the *\Storage Card* folder are distributed on the RAC6182 Applications and Accessories CD-ROM. Create the necessary folders and copy the files to these folders. See the RAC6182 Storage Card Folders section in Chapter 15, Managing User Applications.
5. Power cycle the RAC6182 and verify that all RAC6182-specific Control Panel applications are loaded.
6. Reload any application programs using the vendor-supplied backup files. Make sure that these programs are compatible with the RAC6182 operating system version, especially if you have reloaded the Windows CE operating system.



## Replacement Parts and Accessories

### Chapter Objective

This chapter describes the replacement parts and accessories that are available for the RAC6182 Industrial Computer, with their corresponding part numbers.

### Replacement Parts

Description	Catalog Number
<b>Computer Chassis:</b>	
AC Power Supply	6189-2ACPS
Terminal block for AC power, DC power and diagnostics relay output	6189-2CONN
64MB DiskOnChip flash ROM	6189-2FL64
64MB DIMM SDRAM	6189-DIMM64
128MB DIMM SDRAM	6189-DIMM128
256MB DIMM SDRAM	6189-1DIMM256
32MB flash PC card (ATA)	6189-ATA32
64MB flash PC card (ATA)	6189-ATA64
Single-channel DH+/RIO/DH485 Network PCI Card	1784-PKTX
<b>Cables:</b>	
RS232 Null Modem Cable	6189-2NMCBL
<b>Software:</b>	
RAC6182 Software Development Kit (Visual C++, Visual Basic)	6189-SDK
Windows CE 3.0 Upgrade	6189-2WINCE30

**Important:** For a replacement chassis assembly, order the RAC6182 non-display unit with the required options (6182-xAxxxx).

Description	Catalog Number
<b>Front Bezel Assembly:</b>	
7.7 in. Keypad front bezel assembly	6189-2LCDBZL8K
7.7 in. Keypad & Touchscreen front bezel assembly	6189-2LCDBZL8KT
12.1 in. Keypad front bezel assembly	6189-2LCDBZL12K
12.1 in. Keypad & Touchscreen front bezel assembly	6189-2LCDBZL12KT
12.1 in. Touchscreen front bezel assembly	6189-2LCDBZL12T
7.7 in. Keypad plastic bezel & overlay	6189-2BZL8K
7.7 in. Keypad & Touchscreen plastic bezel & overlay	6189-2BZL8KT
12.1 in. Keypad plastic bezel & overlay	6189-2BZL12K
12.1 in. Keypad & Touchscreen plastic bezel & overlay	6189-2BZL12KT
12.1 in. Touchscreen plastic bezel & overlay	6189-2BZL12T
7.7 in. and 12.1 in. bezel mounting clips (qty 4)	6189-2MTGKIT
7.7 in. bezel legend strip kit (1 set of 3 strips)	6189-2KEYKIT8
12.1 in. bezel legend strip kit (1 set of 3 strips)	6189-2KEYKIT12
12.1 in. Antiglare overlay	6189-1AG121
<b>Input Devices:</b>	
Mouse, panelmount	6189-HPMOUSEP
Keyboard, desktop stainless steel with integral mouse	6189-KBDEPS1
Keyboard, panelmount stainless steel with integral mouse	6189-KBPEPS1
Keyboard, desktop plastic with integral mouse	6189-KBDEPU1
<b>Adapter Plates – 12.1 in. Display:</b>	
To replace a PanelView 1200 keypad, 1400 keypad, 1200e keypad, 1400e keypad	2711-NR5K
To replace a PanelView 1200 touch, 1200e touch	2711-NR5T
To replace a PanelView 1400 touch, 1400e touch	2711-NR7T

## Specifications

<b>7.7 in. Display</b>	
Type	Dual Scan Color Super Twisted Numatic (STN) LCD
Nominal Display Area	
Horizontal	6.2 in (157 mm)
Vertical	4.6 in (118 mm)
Viewing Angle	
Horizontal (typical)	+/- 50 degrees
Vertical (typical)	+50/-30 degrees
Resolution	640x480 (VGA)
Response Time (typical)	270 msec rise, 80 msec decay
Luminance (typical)	120 nit, 35 fL (overlay option will affect luminance)
Contrast Ratio (typical)	50:1
CIE coordinates: White	X=0.275 Y=0.330
Backlight life	40,000 hours to half-brightness
Touchscreen Rating	Minimum 20 x 20 pixels touch cell 1,000,000 presses
Keypad Rating	3,000,000 presses
<b>12.1 in. Display</b>	
Type	Active Matrix Color Thin-Film-Transistor (TFT) LCD
Nominal Display Area	
Horizontal	9.7 in (246 mm)
Vertical	7.3 in (185 mm)
Viewing Angle	
Horizontal (typical)	+/- 60 degrees
Vertical (typical)	+55/-45 degrees
Resolution	800x600 (SVGA), 256K (18 bit) colors
Response Time	30 msec (typical)
Luminance (typical)	250 nit, 73 fL (overlay option will affect luminance)
Contrast Ratio (typical)	300:1
CIE coordinates: White	X= 0.313 Y= 0.329
Backlight life	50,000 hours to half-brightness
Touchscreen Rating	Minimum 25 x 25 pixels touch cell 15,000,000+ presses
Keypad Rating	3,000,000 presses
<b>Non-display</b>	
Video Port	HD15 video connector, analog
Resolution	640x480 (VGA), 800x600 (SVGA), 1024x768 (XVGA)

<b>Mechanical</b>	
Enclosure	
Display versions	NEMA 12, 13, 4X (indoor) when panel mounted. (IP65)
Non-display version	NEMA 1
LED Indicators	
Display versions	Two green and one red indicators on front bezel
Non-display version	None
Dimensions (overall)	Height x Width x Depth (bezel dimensions)
7.7 in. with keypad	223.6 mm x 321.5 mm x 75.4 mm 8.80 in x 12.66 in x 2.97 in
12.1 in. with keypad	282.6 mm x 415.7 mm x 75.8 mm 11.12 in x 16.36 in x 2.98 in
12.1 in. with touchscreen	282.6 mm x 363.3 mm x 75.8 mm 11.12 in x 14.3 in x 2.98 in
Non-display	195.8 mm x 330.2 mm x 57.3 mm 7.71 in x 13.00 in x 2.26 in
Dimensions (panel cutout)	Rectangular cut-out – Height x Width
7.7 in. with keypad	197.8 mm (7.79 in) H x 295.8 mm (11.65 in) W
12.1 in. with keypad	256.8 mm (10.11 in) H x 389.9 mm (15.35 in) W
12.1 in. with touchscreen	256.8 mm (10.11 in) H x 337.6 mm (13.29 in) W
Weight	
7.7 in. with keypad	8.65 lbs (4.0 kg)
12.1 in. with keypad	11.65 lbs (5.3 kg)
12.1 in. with touchscreen	11.15 lbs (5.1 kg)
Non-display	6.65 lbs (3.0 kg)
Shipping Weight (approx.)	
7.7 in. version	15 lbs (6.8 kg)
12.1 in. version	20 lbs (9.1 kg)
Non-display version	13 lbs (5.8 kg)

<b>Environmental</b>	
Operating Temperature	0 C to 50 C
Storage Temperature	-25 C to 60 C
Relative Humidity *	8% to 80% non-condensing
Operating Altitude	Sea level to 10,000 ft (3048m)
Non-Operating Altitude	Sea level to 40,000 ft (12000m)
Operating Shock	15g (1/2 sine, 11 msec)
Non-operating Shock	30g (1/2 sine, 11 msec)
Operating Vibration	0.006in. p-p, 10-57Hz 1.0G peak, 57-150Hz sine
Non-operating Vibration	0.015 in. p-p, 10-57Hz 2.5g peak, 57-150Hz sine





\* Applications with touchscreens in high-humidity and high-temperature environments have additional considerations.

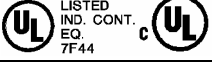

<b>Electrical (AC Option)</b>	
Line Voltage	85 to 132VAC, 170 to 264VAC autoranging
Line Frequency	47-63Hz
Ground Leakage	1.0 uA max at 1.5KVDC
Power Consumption	45/55VA (0.4A @ 120Vrms, 0.25A @ 240Vrms)
Power Dissipation	16W typical (no add-in cards) 24W maximum

<b>Electrical (DC Option)</b>	
Line Voltage	18-32VDC
Input Current	0.8A typical (no add-in cards) 1.4A maximum
Power Consumption	16W typical (no add-in cards) 24W maximum

<b>Diagnostic Relay Output</b>	
Relay rating	0-24V AC or DC. Normally open
Maximum current	0.5A at 24VDC.

<b>Agency Approvals</b>	
	UL 508 Listed UL/C-UL Industrial Control Equipment
CLASS I, DIVISION 2 GROUPS A,B,C. & D <b>INDUSTRIAL FLAT PANEL MONITOR</b> 	UL 1604 Listed UL/C-UL Industrial Flat Panel Monitor
	UL 1950 Recognized Component, C-UL 950 Recognized Component
	LVD (73/23/EEC) EN 60950 EMC (89/336/EEC) EN 50081-2: 1993 EN 55022: 1998 Class A EN 55024: 1998 EN 61326: 1998 EN 61000-3-2: 1995 EN 61000-3-3: 1995

Note: With a 1784-PKTX communication module, the system does not meet CID2.



## Processor Board Specifications

### Processor Board Specifications

The following table lists the RAC6182 Industrial Computer processor board specifications:

Item	Description
Processor	QED MIPS R4300 32-bit RISC processor, 225MHz
Boot Code	Version contained on ROM label
Main Memory	32Mbytes or 64Mbytes flash ROM memory, DiskOnChip device (100 nsec access)
RAM Memory	64Mbytes, 128Mbytes or 256Mbytes 100MHz SDRAM (10 nsec access)
Video Interface	MediaQ MQ-200 2Mbytes VGA local memory Internal LVDS interface to LCD panel External HD15 CRT (analog monitor) connector
Ethernet	PCI 10/100BaseT Intel 82559 MAC RJ-45 connector with indicator LEDs
Other CPU I/O	Two RS232 serial ports (COM1 and COM2) ECP/EPP Parallel port Two PS/2 ports for keyboard & mouse connections Two USB ports Output Relay
System Hardware Monitor	Battery +3.3V supply +5V supply +12V supply Temperature

### Boot Code Information

The RAC6182 Industrial Computer contains a boot ROM that contains the basic routines required to start up the RAC6182 computer and load the Windows CE operating system from the DOC flash ROM into the computer DRAM. The boot code can be field upgraded coincident with an operating system upgrade.



## **RAC6182 Compatible Devices**

### **Parallel Port Printers**

The Windows CE operating system includes a PCL3 printer driver. This driver supports printing on most laser and ink-jet printers. If you experience problems using a printer, verify that your printer is compatible with the PCL3 print driver.

The following printers have been tested and are known to work satisfactorily with the RAC6182 Industrial Computer:

- HP LaserJet 5
- HP LaserJet 2100
- HP DeskJet 1600CN

### **PC Cards**

The following PC cards are compatible with the RAC6182 Computer:

M-Systems ATA Flash PC Card 2000  
SanDisk Flash Disk PCMCIA PC Card ATA  
SimpleTech ATA PC Card



## RAC6182 Point-to-Point Communications

### COM2 RS232 Communications

The following table defines the wiring needed to the serial communication (COM2) cable. This cable is needed to transfer debug output to a host computer or perform data exchange via Microsoft ActiveSync.

**Table Q**  
**Null Modem Cable (6189-2NMCBL)**

Signal Name	DB9 (Female) Pin to...	DB9 (Female) Pin	Signal Name
DCD	1	7,8	RTS, CTS
RX	2	3	TX
TX	3	2	RX
DTR	4	6	DSR
GND	5	Open	Open
DSR	6	4	DTR
RTS	7	1	DCD
CTS	8	1	DCD
RI	9	Open	Open
SHIELD	10	10	SHIELD





## 1

- 12.1 in keypad bezel operation
  - Connecting a keyboard, 8-11
  - Installing the Keypad Configuration Utility, 8-9
  - Keypad default key assignments for programmable keys, 8-32, 8-33
  - Setting up and using the Keypad Configuration Utility (KCU) software, 8-8
  - Using the Keypad Configuration Utility, 8-11
- 12.1 in. version with keypad, dimensions, 2-3
- 12.1 in. version with touchscreen, dimensions, 2-4

## 6

- 6182 Computer
  - communications settings, 13-1
  - compatible devices, C-1
  - connecting external devices, 3-1
  - connectors, 1-8
  - display settings, 9-1
  - features, 1-5
  - hardware monitor, 11-1
  - installation, 2-1
  - keypad, 8-1
  - opening chassis, 4-2
  - operating recommendations, 6-1
  - removing chassis, 4-2
  - resetting, 12-1
  - resetting Windows CE registry, 15-4
  - restoring to factory configuration, 16-2
  - specifications, A-1
  - system checkout, 6-1
  - touchscreen settings, 10-1
  - user applications, 14-1
  - versions, 1-1
  - watchdog timer, 12-1
  - Windows CE operating system, 7-1

## 7

- 7.7 in. version with keypad,dimensions, 2-3

## A

- ActiveSync. *See* Microsoft ActiveSync
- Add-in cards, thermal considerations, 4-2
- Applications
  - compiling, 7-1
  - installing, 7-2, 14-1
  - standard Windows CE applications, 7-2

## B

- Backlight tubes, installing or removing, 5-1
- Battery, replacing, 16-2

## C

- Chassis
  - removing, 4-2
- Clearances, 2-2
- Communications settings, 13-1
- Compatible devices, C-1
- Connecting
  - diagnostic relay output, 3-9
  - external video monitor, 3-8
  - keyboard, 3-3
  - mouse, 3-3
  - network, 3-4
  - parallel devices, 3-7
  - serial devices, 3-6, D-1
  - USB devices, 3-2
- Connectors, 1-8
- Cutout dimensions, 2-5

## D

- Diagnostic relay output connections, 3-9
- Diagnostics, hardware, 11-1, 15-1

## Dimensions

- 12.1 in. version with keypad, 2-3
- 12.1 in. version with touchscreen, 2-4
- 7.7 in. version with keypad, 2-3
- non-display version, 2-4

## Disk-On-Chip devices

- adding or removing, 4-1, 4-9
- memory usage, 7-7

## Display settings, 9-1

DOC device. *See* Disk-On-Chip devices

**E**

Ethernet connections, 3-4

**F**

Files, transferring, 14-3, 14-4

Flash memory. *See* Memory

## Front bezel assembly

- cables, installing or removing, 5-1
- disassembling, 5-2
- installing or removing, 5-1
- plastic overlay, installing or removing, 5-1

**H**

Hardware monitor, 11-1, 15-1

**I**

## Installation

- clearances, 2-2
- cutout dimensions, 2-5
- dimensions, 2-3, 2-4
- mounting hardware, 2-1
- panel mounting, 2-5
- power, 2-7
- relay output, 2-8
- tools required, 2-2

**K**

Keyboard connections, 3-3

## Keypad, 8-13

- configuration, 8-7
- layout, 8-1
- legend strips, 5-6
- operation, 8-1

Keypad Configuration Utility (KCU). *See* 12.1 in keypad bezel operation

## Keypad legend strips

- installing or removing, 5-1

**L**

## LED indicators

- description, 1-9
- resetting the Diagnostics LED, 11-1

Legend strips. *See* Keypad legend strip

**M**

## Maintenance, 16-1

- cleaning the display, 16-1
- replacement parts, 17-1, 17-2
- replacing the battery, 16-2
- restoring to factory configuration, 16-2

## Memory

- adding or removing, 4-1, 4-8
- battery-backed non-volatile RAM, 7-8
- boot flash ROM, 7-7
- Disk-On-Chip flash ROM, 7-7
- flash memory PC cards, 7-8

## Microsoft ActiveSync

- applications, 7-2
- installing, 14-1

## Mouse

- connections, 3-3
- disabling the mouse cursor, 10-3

**N**

Network connections, 3-4

Non-display version, dimensions, 2-4

**O**

Operator access, 6-1

**P**

Panel mounting, 2-5

Parallel device connections, 3-7

Parts, 17-1, 17-2

PC cards

adding or removing, 4-1

compatible cards, C-1

memory usage, 7-8

PC Link application, 7-2

PCI add-in cards, adding or removing, 4-1

PCMCIA cards. *See* PC cards

Power connections, 2-7

Printers, C-1

Processor board specifications, B-1

**R**

RAM. *See* Memory

Registry, resetting Windows CE, 15-4

Relay output connections, 2-8

Restoring to factory configuration, 16-2

**S**

Serial devices

connections, 3-6

null modem cable requirement, D-1

Setup, initial operation, 6-1

Specifications

general, A-1

processor board, B-1

Storage Card memory, 7-7

System lockup recovery, 12-1

**T**

Touchscreen settings, 10-1

Transferring files, 14-4

Troubleshooting

check lists, 15-2

hardware diagnostics, 15-1

procedures, 15-1

restoring to factory configuration, 16-2

**U**

USB devices, 3-2

Using, 8-11

**V**

Versions of 6182 Computers, 1-1. *See also* 7.7 in.  
display version, 12.1 in. display version, Non-  
display version

Video monitor connections, 3-8

**W**

Watchdog timer, 12-1

Windows CE applications

installing and removing, 14-3

transferring files, 14-4

Windows CE operating system, 7-1

architecture, 7-1

benefits, 7-1

compiling applications, 7-1

Control Panel applications, 7-6

installing applications, 7-2

interface, 7-3

memory usage, 7-7

registry, 15-4

standard programs, 7-2

upgrading, 14-4









IBM is a registered trademark of International Business Machines Corporation.

VGA is a trademark of International Business Machines Corporation.

PC AT is a trademark of International Business Machines Corporation.

Microsoft is a registered trademark of Microsoft Corporation.

Microsoft Windows is a trademark of Microsoft Corporation.

**[www.rockwellautomation.com](http://www.rockwellautomation.com)**

---

**Power, Control and Information Solutions Headquarters**

Americas: Rockwell Automation, 1201 South Second Street, Milwaukee, WI 53204-2496 USA, Tel: (1) 414.382.2000, Fax: (1) 414.382.4444

Europe/Middle East/Africa: Rockwell Automation, Vorstlaan/Boulevard du Souverain 36, 1170 Brussels, Belgium, Tel: (32) 2 663 0600, Fax: (32) 2 663 0640

Asia Pacific: Rockwell Automation, Level 14, Core F, Cyberport 3, 100 Cyberport Road, Hong Kong, Tel: (852) 2887 4788, Fax: (852) 2508 1846